

MOS EISLEY
CANTINA™
STAR WARS

MASTER
BUILDER
SERIES

SÉRIE
MAÎTRE
CONSTRUCTEUR



STAR
WARS™

75290

CANTINA DE
MOS EISLEY™

CANTINA DE
MOS EISLEY



Booklet available in English on
Livret disponible en français sur
Folleto disponible en español en
LEGO.com/service/buildinginstructions

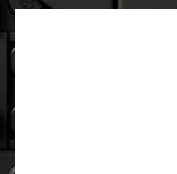



ABOUT THE LEGO® STAR WARS™ DESIGN TEAM

On behalf of the LEGO® *Star Wars*™ design team, welcome to the Mos Eisley Cantina. Any Rebel should feel right at home with the diverse cast of aliens, smugglers, musicians, bounty hunters, star pilots and Jedi Knights, complete with all the danger, adventure and space skullduggery you would expect from such a place.

The scene from Chalmun's Cantina in *Star Wars: A New Hope* has been on our brick-it list – and fans' wish lists – for a long time. (We think it's worth the wait.) We have packed it full of details from the movie and included more than 20 iconic characters to make it look great on your display shelf!

So, claim your favorite spot in the bar, pour yourself a blue milk or Alderaanian ale and enjoy building this epic part of the LEGO *Star Wars* Master Builder Series.



Jens Kronvold Frederiksen

Design Director & Creative Lead,
LEGO® *Star Wars*™

À PROPOS DE L'ÉQUIPE DE CONCEPTION LEGO® STAR WARS™

Au nom de l'équipe de conception LEGO® *Star Wars*™, bienvenue à la cantina de Mos Eisley. Tout rebelle trouvera sa place parmi cette pléthore disparate d'extraterrestres, de contrebandiers, de musiciens, de chasseurs de primes, de pilotes étoiles et de Chevaliers Jedi, et n'aura aucun mal à braver les dangers, les aventures et les magouilles spatiales qu'on retrouve dans un tel endroit.

La scène de la cantina de Chalmun dans *Star Wars : Un Nouvel Espoir* a longtemps été sur notre liste de concepts à réaliser - et sur la liste de souhaits des adeptes. (Nous pensons que le modèle valait le coup d'attendre.) Nous avons ajouté énormément de détails du film et inclus plus de 20 personnages emblématiques pour que le modèle ait l'air grandiose sur votre étagère !

Alors, installez-vous à votre coin préféré, versez-vous un lait bleu ou une bière alderaanienne et prenez plaisir à construire cet ensemble épique de la série Maître constructeur LEGO *Star Wars*.



Jens Kronvold Frederiksen

Directeur de la conception et responsable de la création,
LEGO® *Star Wars*™

ACERCA DEL EQUIPO DE DISEÑO DE LEGO® STAR WARS™

En nombre del equipo de diseño de LEGO® *Star Wars*™, te damos la bienvenida a la Cantina de Mos Eisley. Todo rebelde que se respete se sentirá como en casa entre el variado elenco de alienígenas, contrabandistas, músicos, cazarrecompensas, pilotos estelares y Caballeros Jedi que la frecuenta, con todo el peligro, la aventura y las artimañas espaciales que se esperan de un lugar como este.

La escena de *Star Wars: Una Nueva Esperanza* en la que aparece la famosa cantina de Chalmun lleva mucho tiempo en nuestra lista de "versiones LEGO pendientes", y no menos en las listas de deseos de los fans. ¡Pero creemos que la espera ha valido la pena! La hemos llenado hasta arriba de detalles de la película y hemos incluido más de 20 personajes inconfundibles para que se vea espectacular en tu vitrina de modelos.

Adelante, ocupa tu lugar favorito en la barra, sírvete un vaso de leche azul o una copa de cerveza Alderaaniana, y disfruta construyendo este épico episodio de la colección LEGO *Star Wars*: Master Builder Series.



Jens Kronvold Frederiksen

Design Director & Creative Lead,
LEGO® *Star Wars*™

MEET THE MODEL DESIGNER

César Carvalhosa Soares
LEGO® Star Wars™ Designer

The first time I watched the Cantina scene in *Star Wars: A New Hope*, I was 12 years old. I just loved the gloomy feeling. I thought, 'this is where the adventure starts!' Our unlikely heroes meet for the first time in this "wretched hive of scum and villainy." It was the perfect way to set the tone for all the adventures that followed.



RENCONTRE AVEC LE CONCEPTEUR DU MODÈLE

César Carvalhosa Soares
Concepteur LEGO® Star Wars™

La première fois que j'ai vu la scène de la cantina dans *Star Wars : Un Nouvel Espoir*, j'avais 12 ans. J'ai adoré l'ambiance lugubre. Je me suis dit : « C'est là que l'aventure commence ! » Nos héros improbables se rencontrent pour la première fois dans « le repaire des malandrins les plus infâmes de toute la galaxie ». C'était le moyen idéal de donner le ton à toutes les aventures qui ont suivi.

CONOCE AL DISEÑADOR DEL MODELO

César Carvalhosa Soares
Diseñador, LEGO® Star Wars™

La primera vez que vi la escena de la cantina en *Star Wars: Una Nueva Esperanza*, tenía 12 años. Me encantó ese ambiente sombrío. Recuerdo que pensé: "¡Aquí es donde comienza la aventura!". Los inesperados héroes se reúnen por primera vez en este "lugar tan lleno de maldad y vileza". Era la forma perfecta de marcar el tono de todas las aventuras que seguían después.

So, when I became a LEGO® *Star Wars*™ designer in 2016, this was the first set I built. It sat on my shelf for a few years until we were ready to release it. We added external buildings like the Jawa shop, refined the details and chose 21 minifigure characters, including all-new alien figures. The movie scene features about 40 characters. I love that all *Star Wars* characters have cool backstories, no matter how briefly they appear. It wasn't easy to decide which characters to include in the set, but we hope fans will love the entire model and its lineup of heroes and villains.



Ainsi, quand je suis devenu un concepteur LEGO® *Star Wars*™ en 2016, c'est le premier ensemble que j'ai construit. Il est resté sur mon étagère pendant quelques années, jusqu'à ce que nous soyons prêts à le sortir. Nous avons ajouté des bâtiments extérieurs comme le commerce des Jawas, affiné les détails et choisi 21 figurines de personnages, dont de toutes nouvelles figurines d'extraterrestres. La scène du film présente une quarantaine de personnages. J'aime le fait que tous les personnages de *Star Wars* ont une histoire passionnante, peu importe la brièveté de leur apparition. Il n'a pas été facile de décider quels personnages seraient inclus dans l'ensemble, mais nous espérons que les amateurs apprécieront le modèle et sa gamme de héros et de méchants.

Así que, cuando me convertí en diseñador de LEGO® *Star Wars*™ en 2016, este fue el primer set que construí. Descansó en mi repisa durante varios años, hasta que estuvimos listos para lanzarlo. Agregamos varios edificios externos, como la tienda del Jawa, refinamos los detalles y elegimos 21 personajes para convertirlos en minifiguras, entre ellos algunos alienígenas inéditos hasta ahora. En la escena de la película, figuran unos 40 personajes. Me encanta que todos los personajes de *Star Wars* tengan historias propias geniales, sin que importe si aparecen solo brevemente en la pantalla. No fue fácil decidir qué personajes incluir en el set, pero esperamos que a los fans les guste el modelo en general, incluida la selección de héroes y villanos.

“THIS PLACE CAN BE A LITTLE ROUGH”

With his home burned to the ground and his family lost, Luke Skywalker sees no alternative but to go to Alderaan with Obi-Wan Kenobi and become a Jedi. Their first stop: The Mos Eisley Cantina, the ideal place to hire a skilled pilot who can outrun Imperial starships, no questions asked. Obi-Wan warns Luke that “this place can be a little rough,” which turns out to be a slight understatement. This is clearly the Wild West of the Outer Rim Territories.

Luke declares himself ready for anything, but our young farm boy barely makes it through the door before facing trial by fire in a fight with Dr. Evazan and Ponda Baba. When Ponda loses his arm to Obi-Wan’s lightsaber, no one raises an eyebrow and the band plays on.

Enter Han Solo, captain of the *Millennium Falcon*/ shady smuggler with a price on his head. A deal is struck that promises our heroes a quick exit from Tatooine, and Han and Chewbacca an urgently needed payday. When Greedo the bounty hunter threatens to get in the way, Han doesn’t hesitate to shoot first. We want to see this motley crew escape against the odds, but can you really trust a smooth-talking star pilot with an itchy trigger finger?



© & ™ Lucasfilm Ltd.

« LES RIXES SONT MONNAIE COURANTE PAR ICI »

Sa maison détruite par le feu et sa famille disparue, Luke Skywalker ne voit pas d’autre choix que de se rendre à Alderaan avec Obi-Wan Kenobi pour devenir un Jedi. Leur premier arrêt : la cantina de Mos Eisley, l’endroit idéal pour trouver un pilote qualifié qui saura semer les vaisseaux impériaux, sans poser de questions. Obi-Wan prévient Luke que « les rixes sont monnaie courante par ici », ce qui s’avère être un léger euphémisme. Il s’agit de toute évidence du Far West des Territoires de la Bordure Extérieure.

Luke se dit prêt à tout, mais le jeune garçon de la campagne a à peine le temps de franchir le pas de la porte qu’il se retrouve défié au combat par le Dr Evazan et Ponda Baba. Quand Ponda se fait trancher le bras par le sabre laser d’Obi-Wan, personne n’en fait grand cas.

C’est là qu’entre en scène Han Solo, capitaine du Faucon Millenium et contrebandier véreux dont la tête a été mise à prix. Un accord qui promet à nos héros une fuite rapide de Tatooine, et à Han et à Chewbacca un salaire dont ils ont grand besoin, est alors conclu. Quand le chasseur de primes Greedo menace de se mettre en travers de leur chemin, Han n’hésite pas à tirer en premier. Nous voulons voir cette équipe hétéroclite s’en sortir contre vents et marées, mais peut-on vraiment faire confiance à un pilote étoile beau parleur qui a la gâchette facile ?



© & ™ Lucasfilm Ltd.

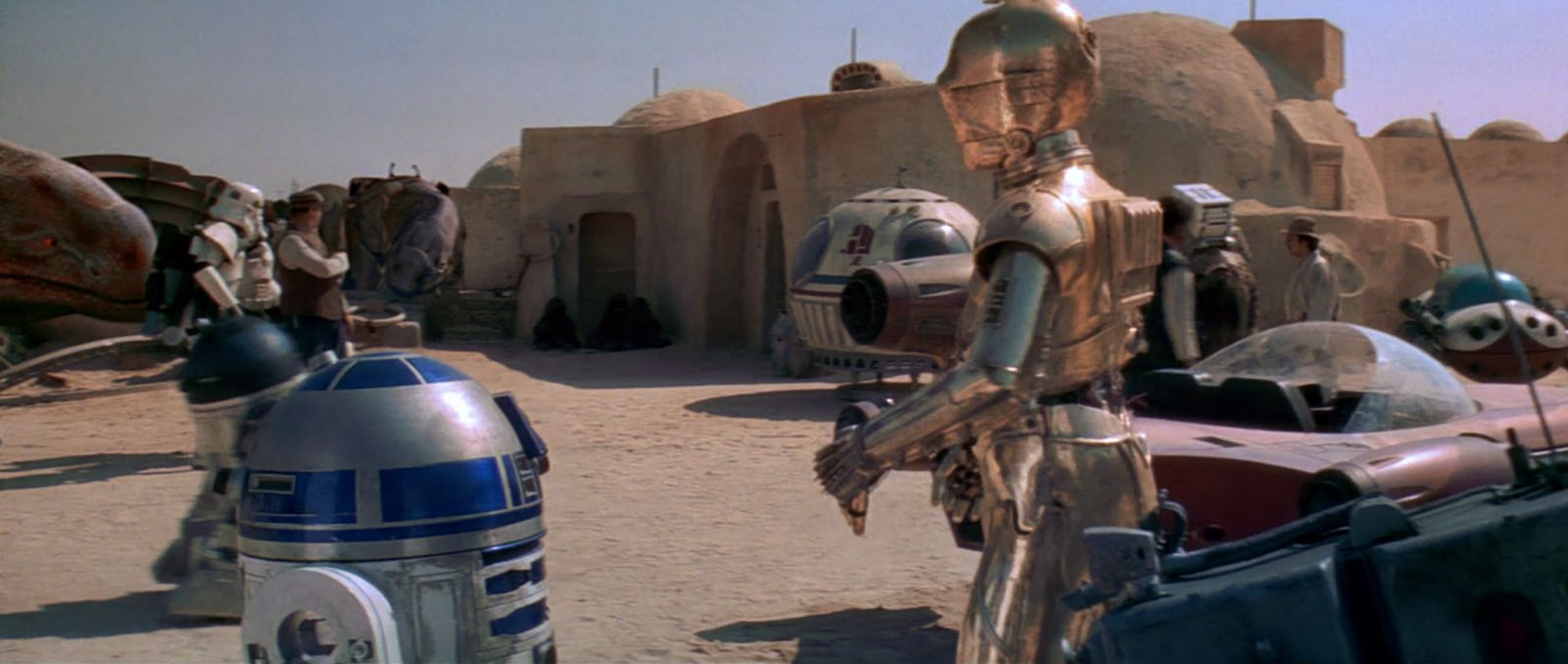

© & ™ Lucasfilm Ltd.

“ESTE LUGAR PUEDE SER PELIGROSO”

Con su hogar reducido a cenizas y su familia perdida, Luke Skywalker no encuentra más alternativa que ir a Alderaan con Obi-Wan Kenobi y convertirse en Jedi. Su primera parada es la Cantina de Mos Eisley: un lugar perfecto para contratar a un piloto hábil, capaz de deshacerse de las naves estelares imperiales sin hacer ninguna pregunta. Obi-Wan le advierte a Luke de que “este lugar puede ser peligroso”, lo que resulta ser poco para lo que les espera. Claramente, están en el salvaje Oeste de los Territorios del Borde Exterior.

Luke se declara preparado para lo que sea, pero, poco después de atravesar la puerta, el joven granjero debe enfrentarse a su primera prueba de fuego al chocar con el Dr. Evazan y Ponda Baba. Cuando Ponda pierde el brazo ante el sable de luz de Obi-Wan, nadie levanta una ceja y la banda sigue tocando.

Entonces aparece Han Solo, capitán del Halcón Milenario y sospechoso contrabandista a cuya cabeza han puesto precio. Se cierra un acuerdo

que promete a nuestros héroes una salida rápida de Tatooine, y una muy necesaria retribución a Han y a Chewbacca. Cuando el cazarrecompensas Greedo amenaza con interponerse en la misión, Han no duda en disparar primero. El espectador espera que la heterogénea tripulación logre escapar contra todo pronóstico, ¿pero será buena idea confiar en un piloto estelar tan charlatán y de gatillo tan fácil?

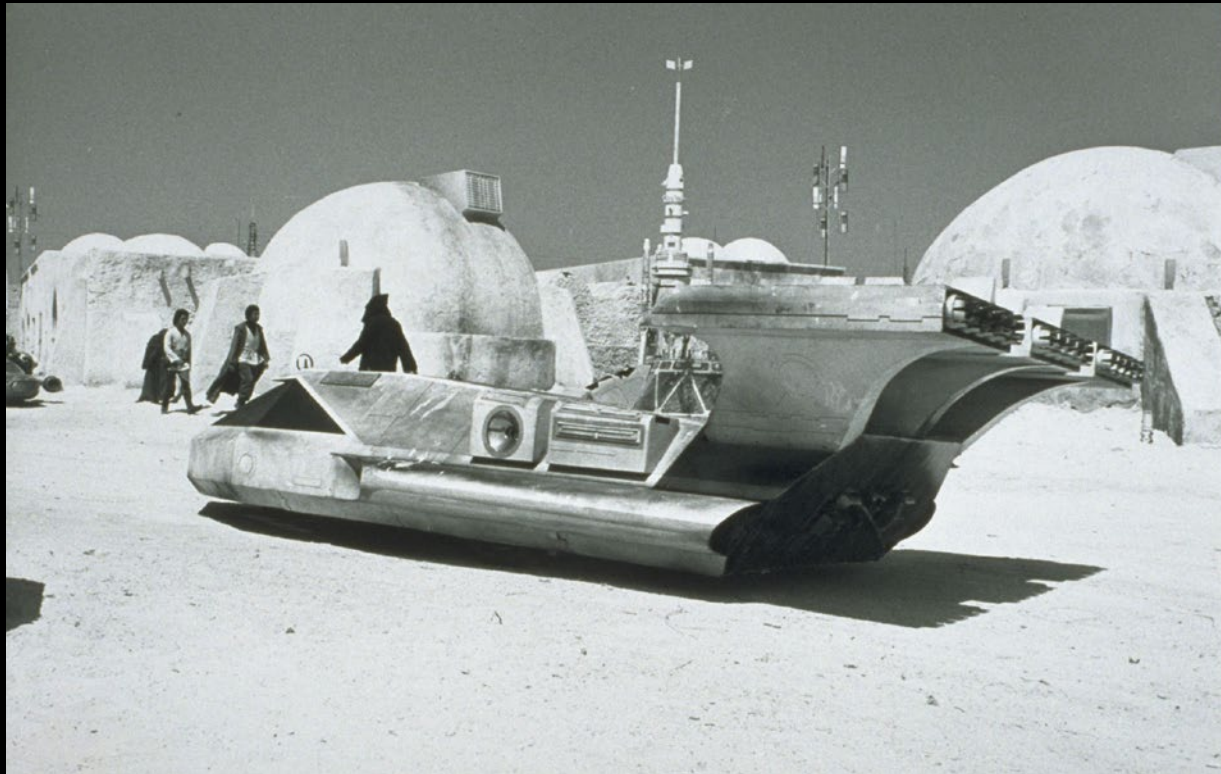

© & ™ Lucasfilm Ltd.

V-35 LANDSPEEDER

This V-35 Landspeeder has never been created as an official LEGO® Star Wars™ model before. The V-35 is an older-model ground transport often used on the galaxy's Outer Rim Territories like Tatooine. An inexpensive but versatile speeder, it is widely used by frontier dwellers and smugglers alike. The LEGO version has room for a driver and a passenger.

LE LANDSPEEDER V-35

Il n'y a jamais eu de modèle officiel de landspeeder V-35 LEGO® Star Wars™ auparavant. Le V-35 est un modèle ancien de véhicule terrestre souvent utilisé dans les Territoires de la Bordure Extérieure, comme Tatooine. Un speeder peu coûteux mais polyvalent, il est généralement utilisé par les frontaliers et les contrebandiers. La version LEGO peut accueillir un conducteur et un passager.

LANDSPEEDER V-35

El landspeeder V-35 nunca ha formado parte oficial de un modelo LEGO® Star Wars™. El viejo modelo de transporte terrestre V-35 se usa con frecuencia en los Territorios del Borde Exterior de la galaxia, como es el caso de Tatooine. Económico y versátil, es altamente popular entre residentes fronterizos y contrabandistas. La versión LEGO tiene espacio para el conductor y un pasajero.



© & ™ Lucasfilm Ltd.



In *Star Wars: A New Hope*, the white and yellow version replicated in this set is only seen briefly in the Cantina scene. We get a glimpse of another version of the V-35 Landspeeder with a different color scheme in Owen and Beru Lars' garage as C-3PO is about to take his oil bath.

Dans *Star Wars : Un Nouvel Espoir*, la version blanche et jaune reproduite dans cet ensemble n'apparaît que très brièvement durant la scène de la cantina. Nous pouvons entrevoir une autre version du landspeeder V-35 avec des couleurs différentes dans le garage d'Owen et de Beru Lars, alors que C-3PO s'apprête à prendre son bain d'huile.

En *Star Wars: Una Nueva Esperanza*, la versión en blanco y amarillo que se reproduce en este set aparece brevemente en la escena de la cantina. También puede verse un landspeeder V-35 con otra combinación de colores en el garaje de Owen y Beru Lars, cuando C-3PO está a punto de tomar su baño de aceite.

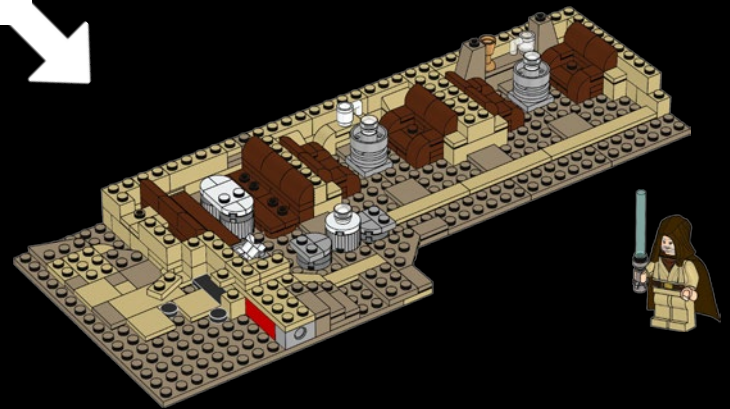
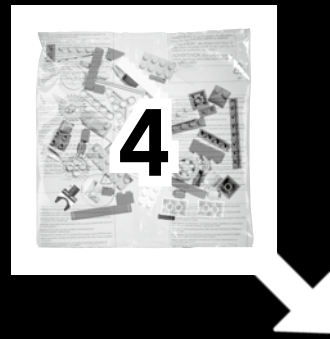
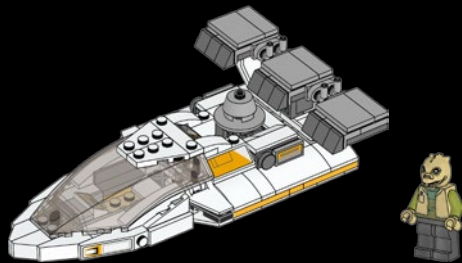
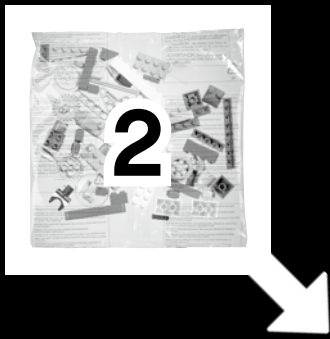
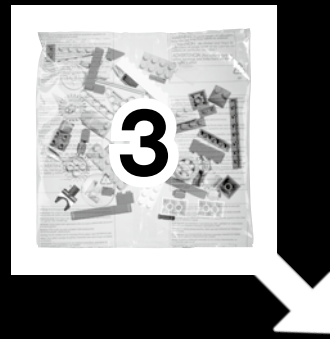
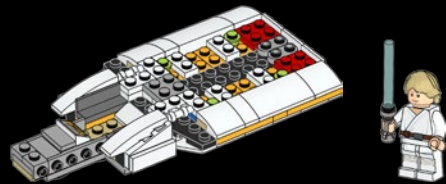

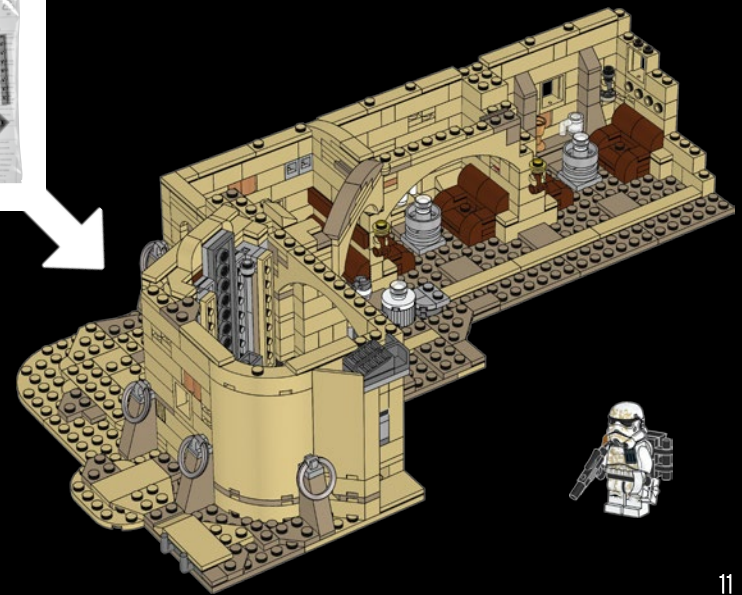
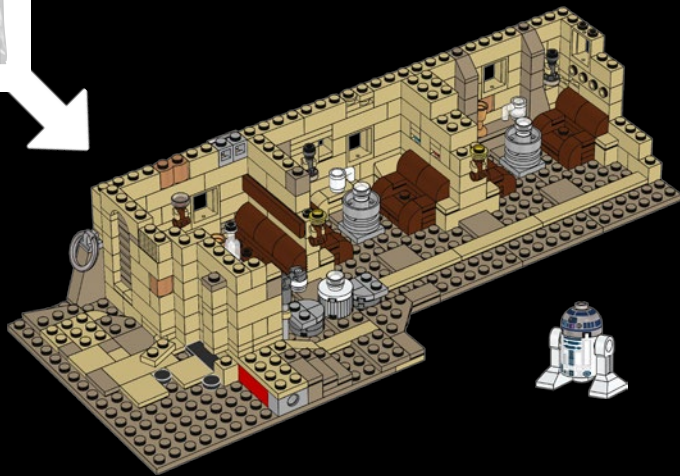
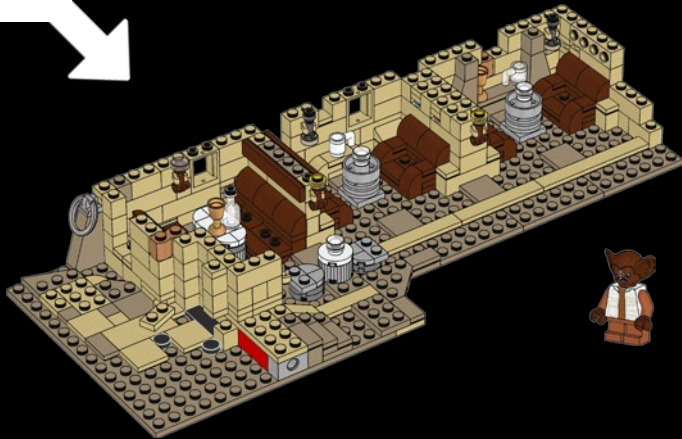



9

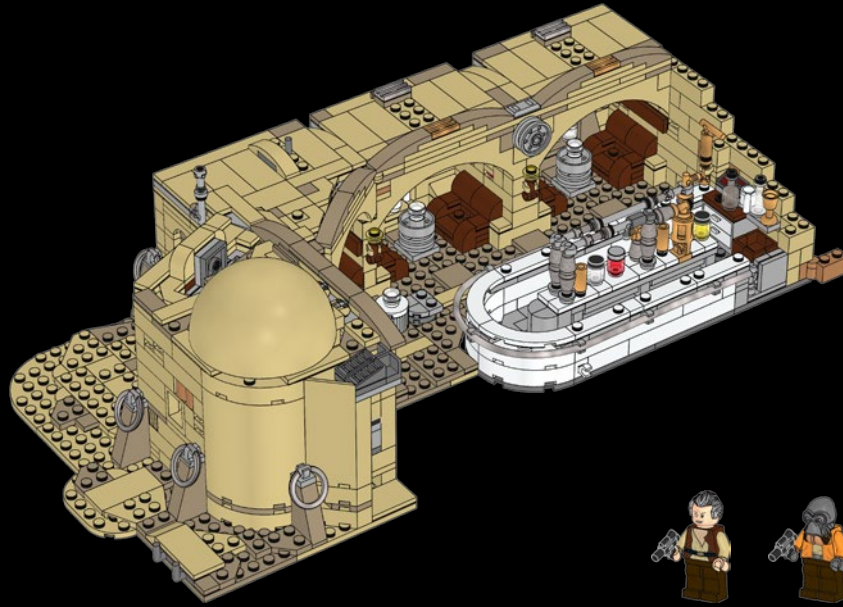

10

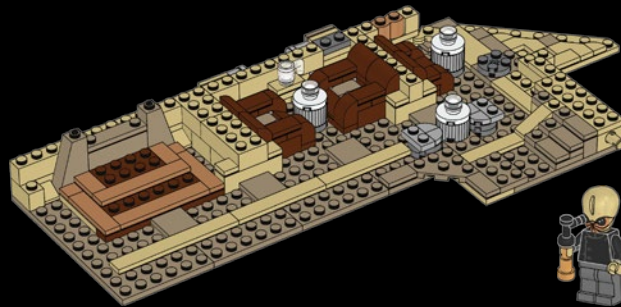



11

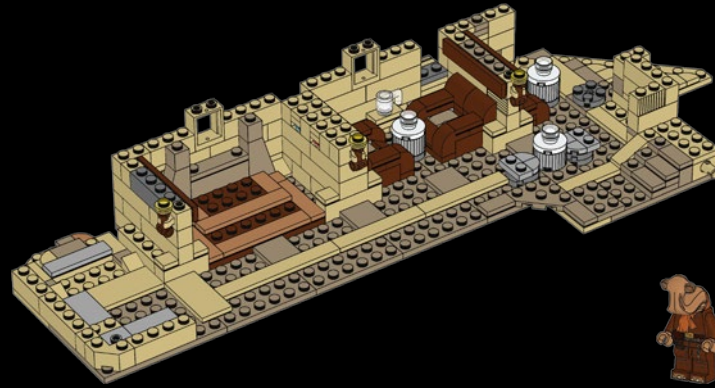

12

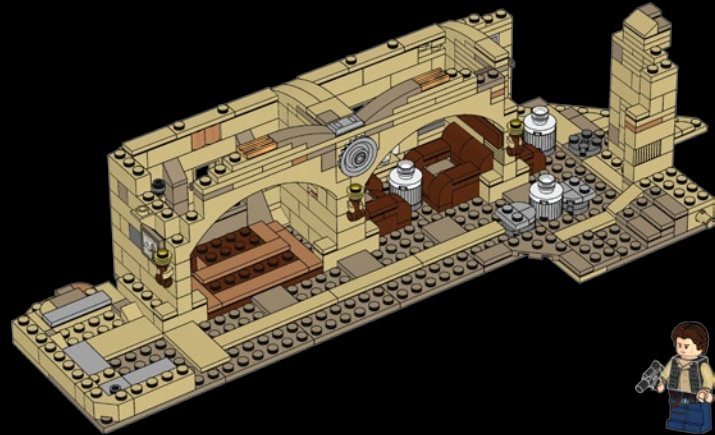
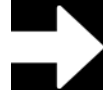



13

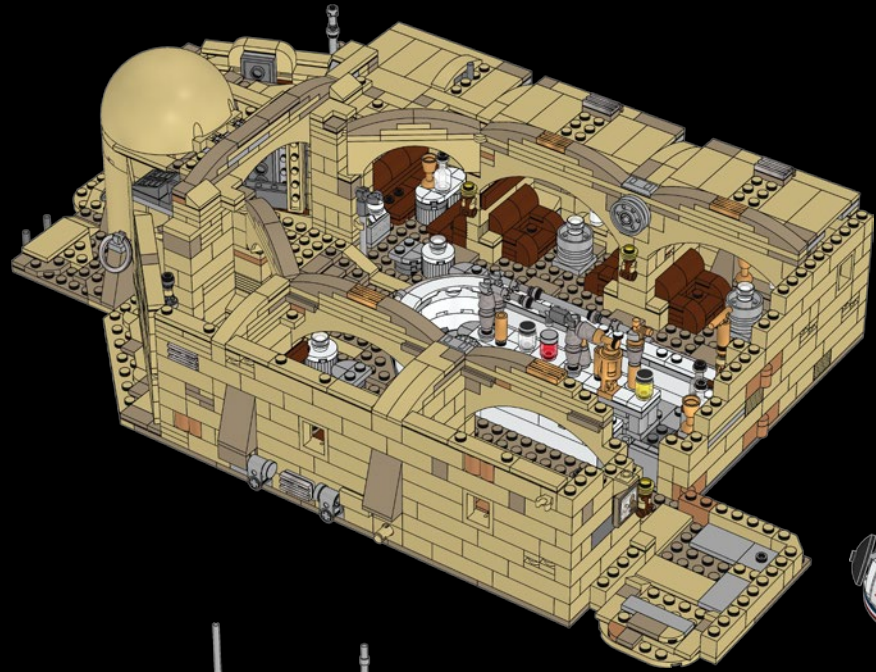

14

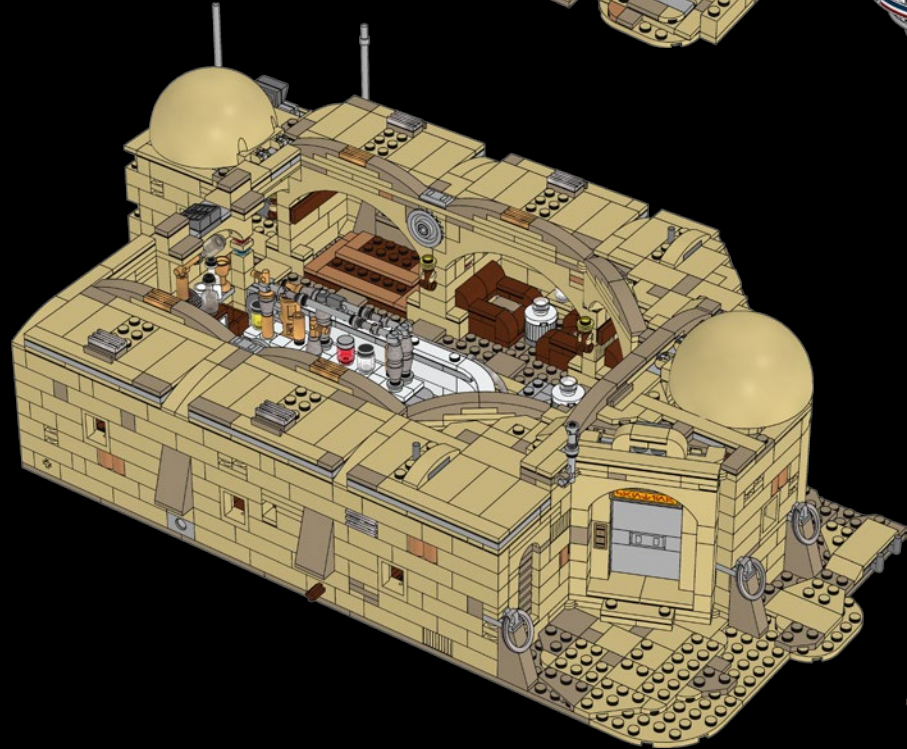

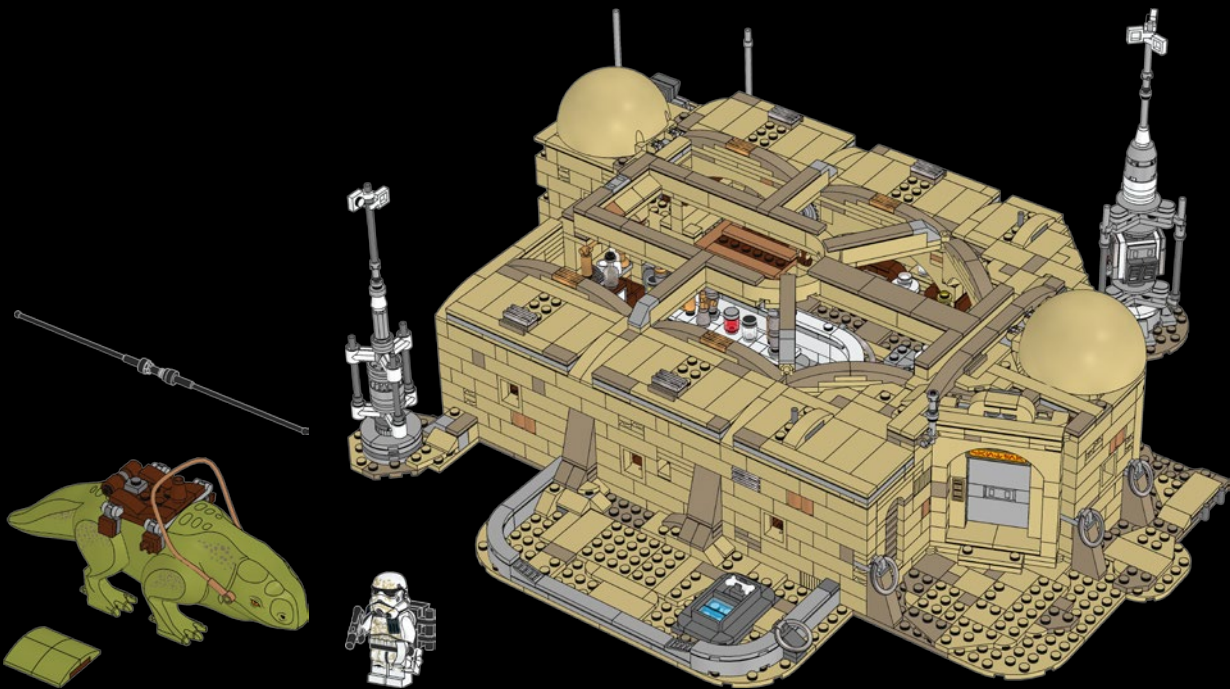
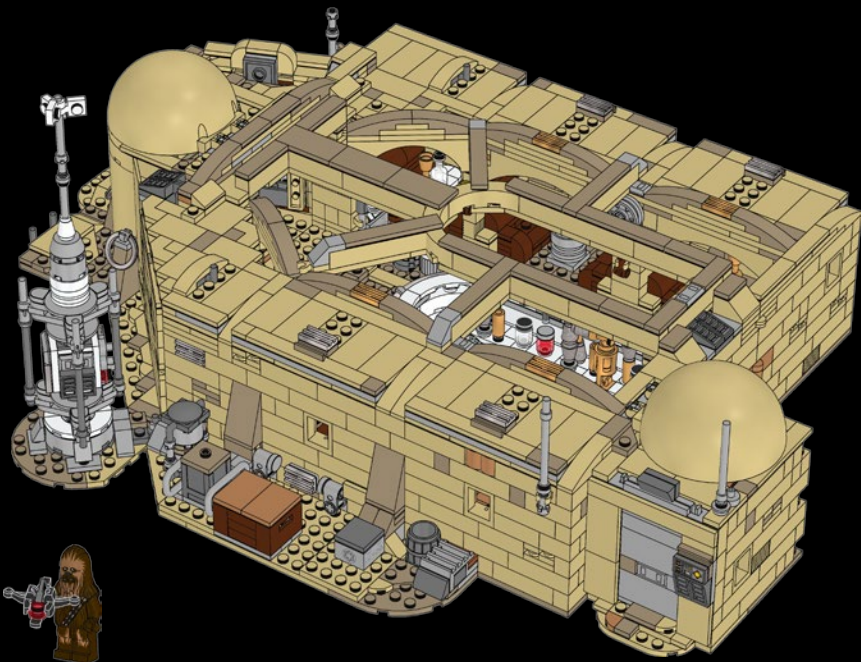

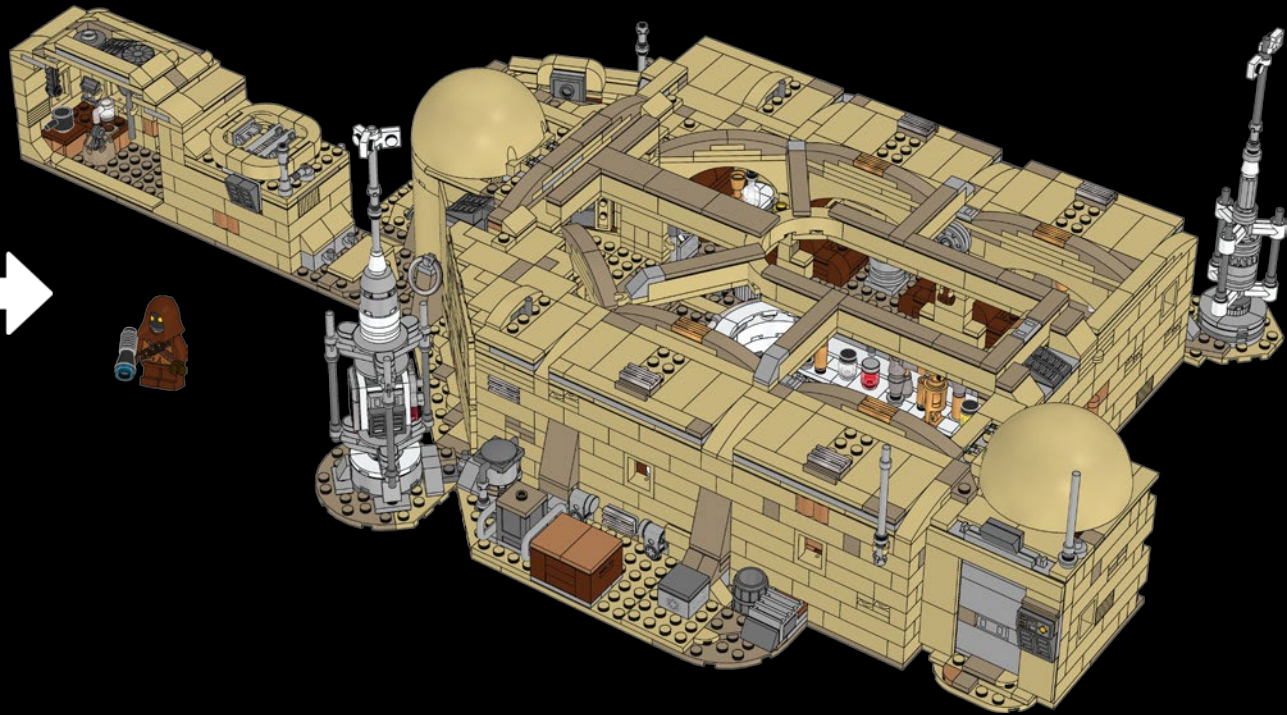

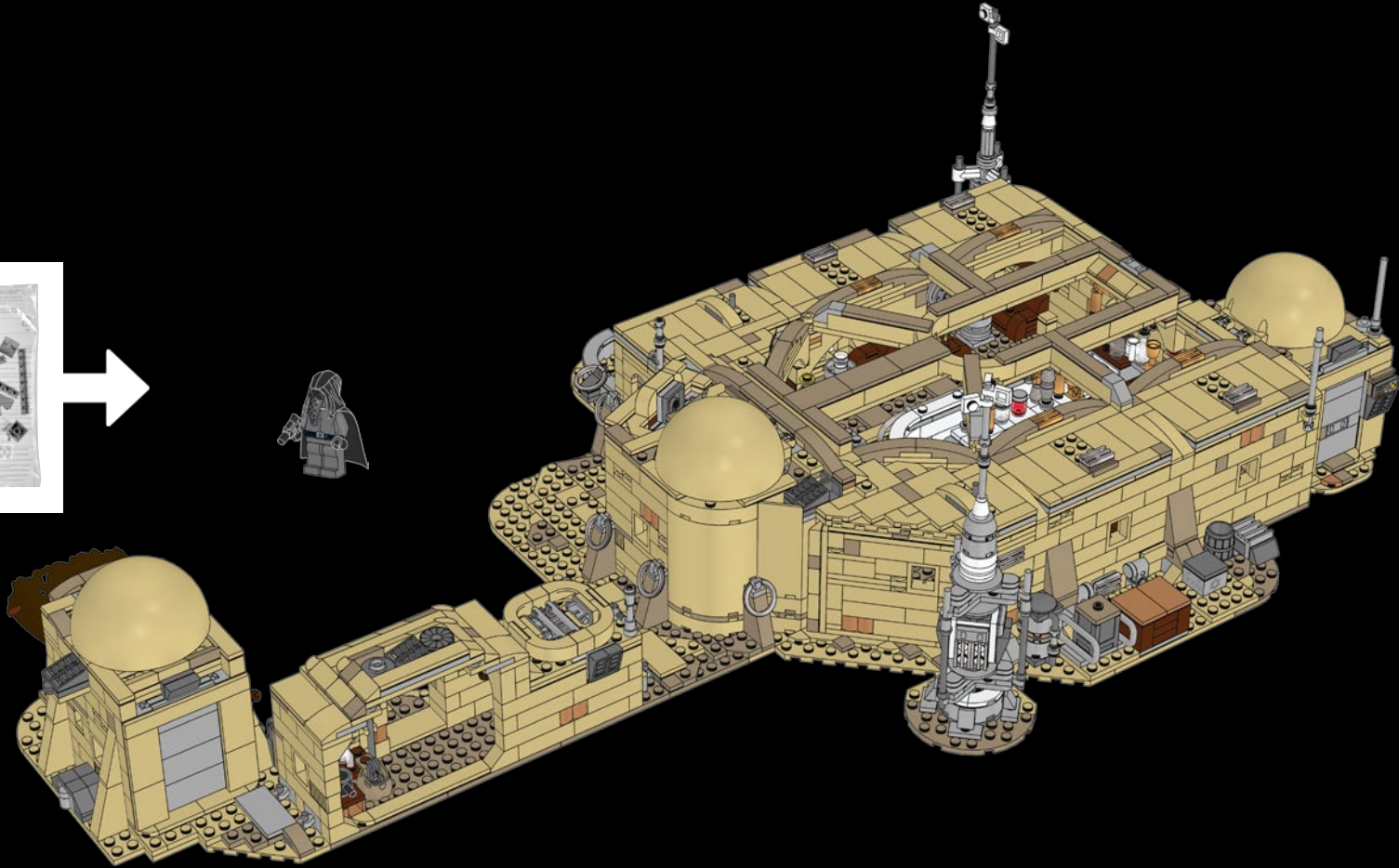



LEGO.com/brickseparator

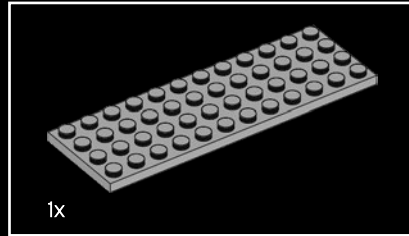
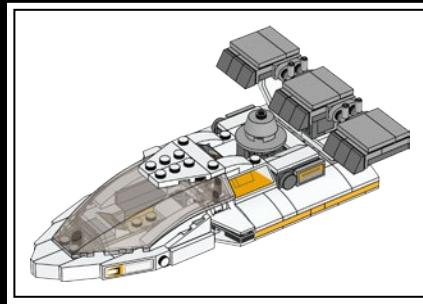
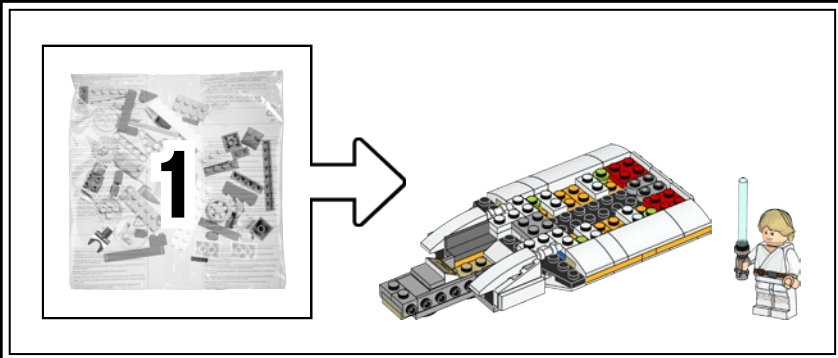

1

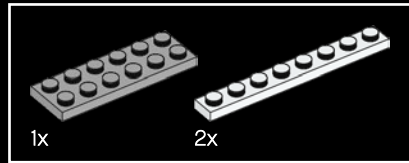
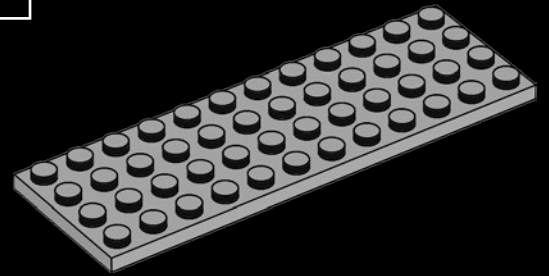

2

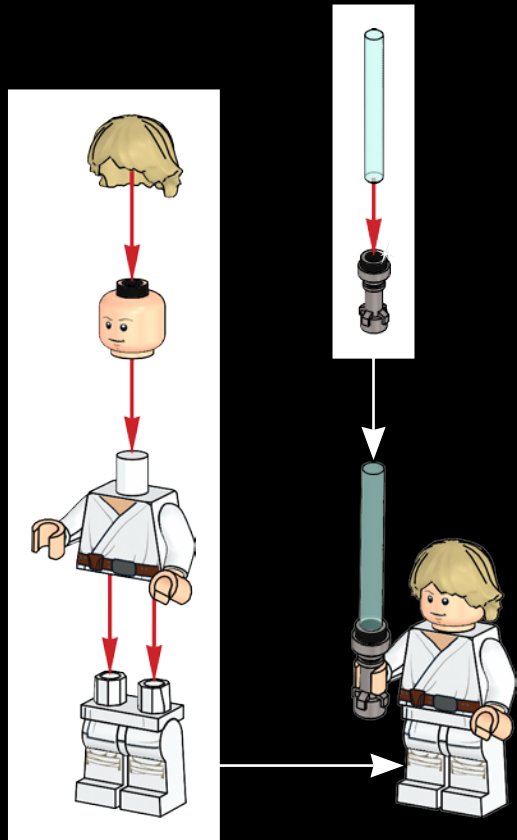
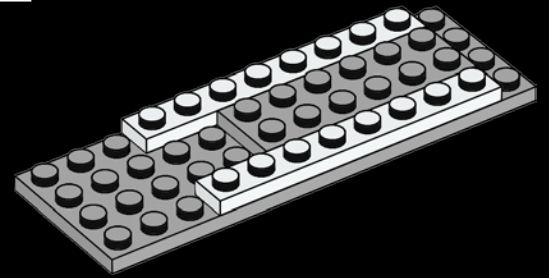

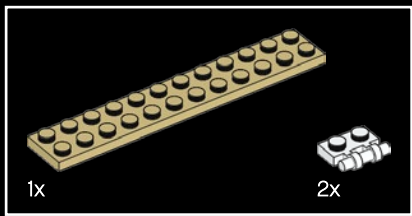

3

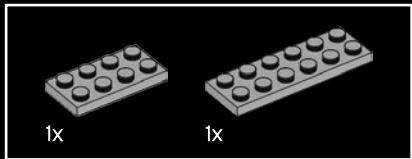
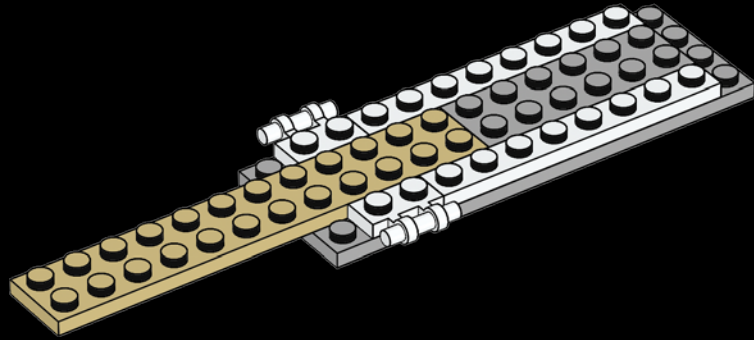

4

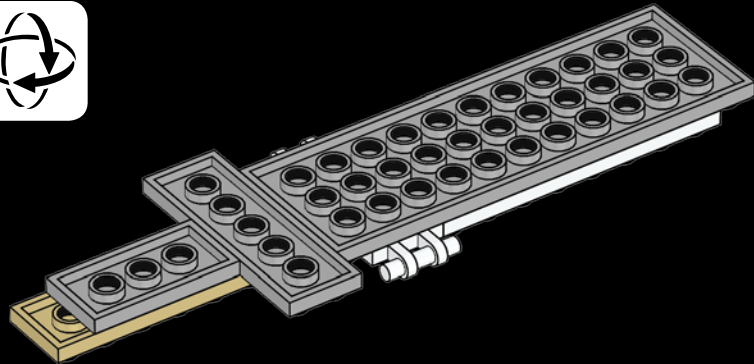

5

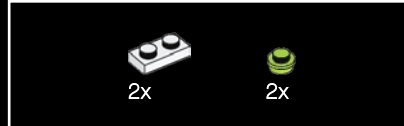
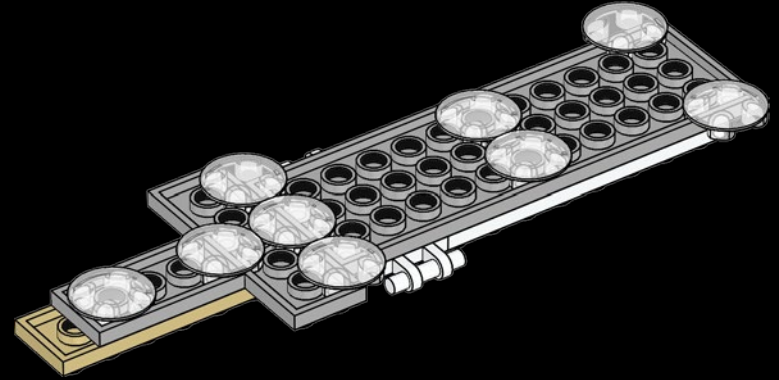

6

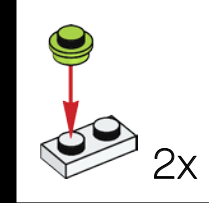

2x

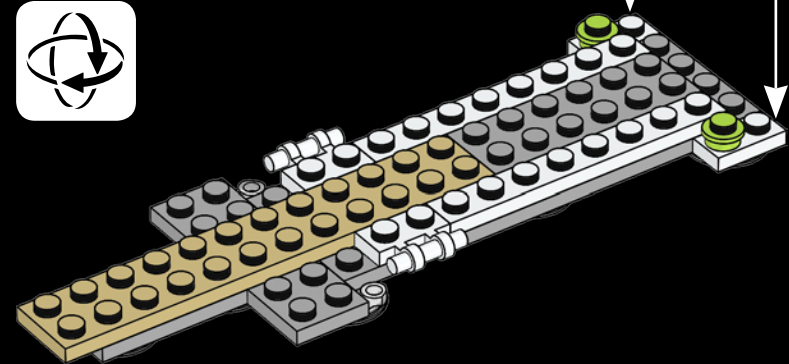



7

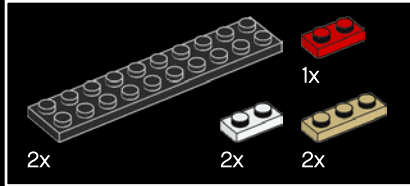
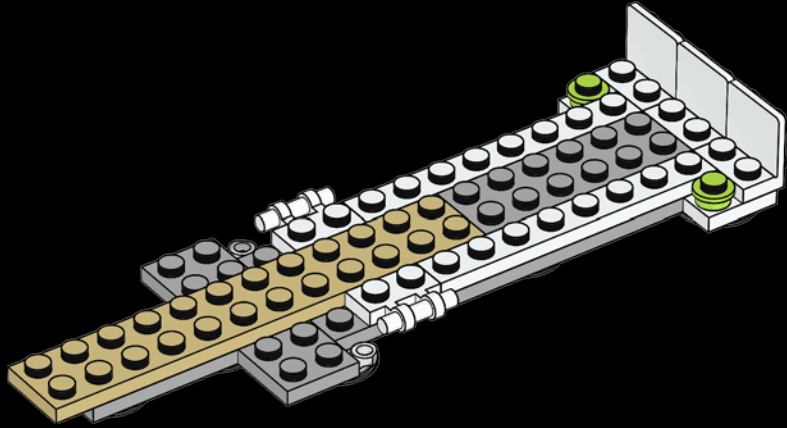

8

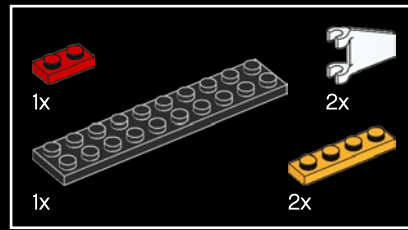
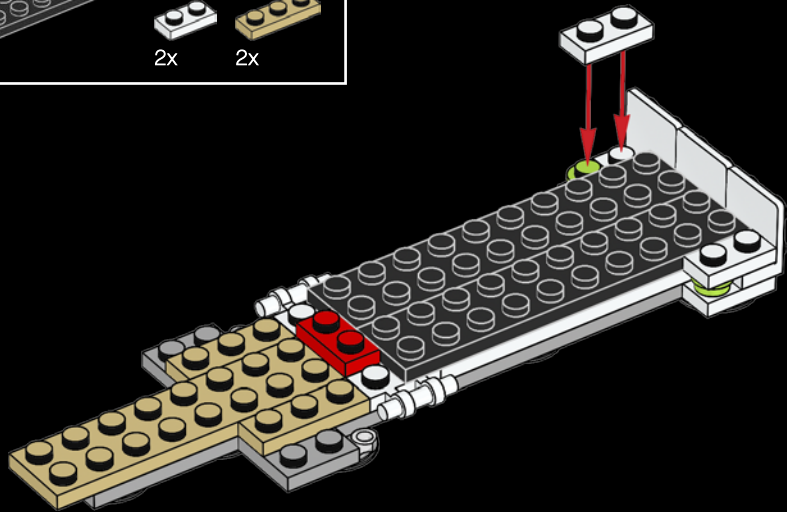

9

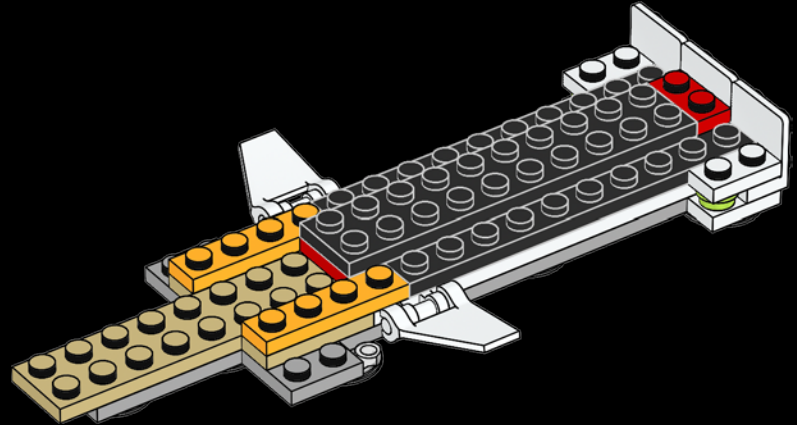

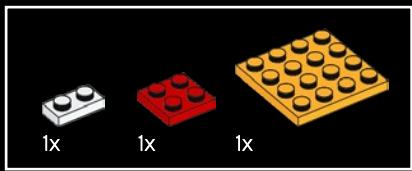

10

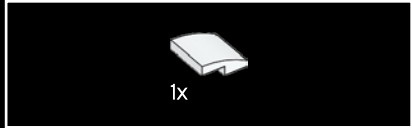
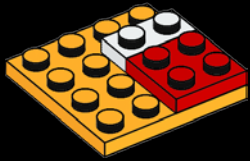

11

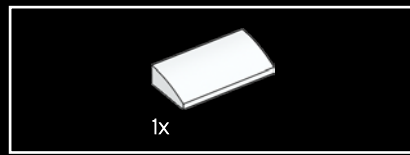
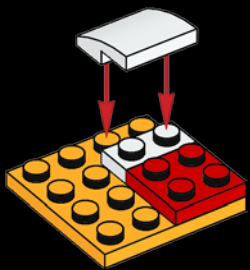

12

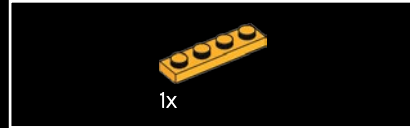
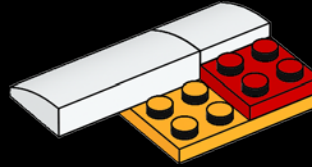

13

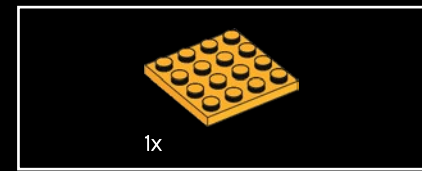
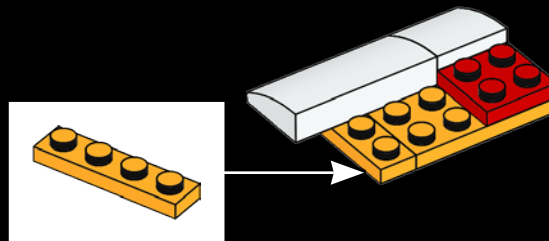

14

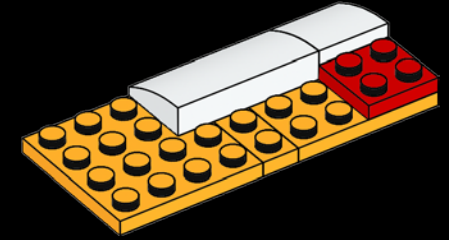

15

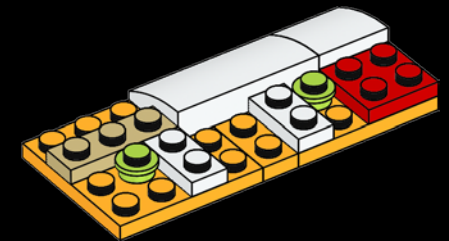

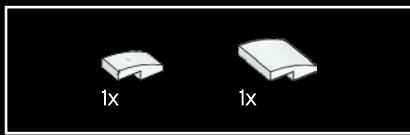

16

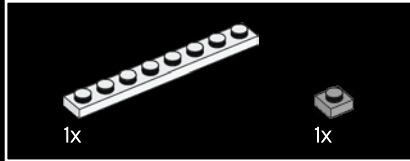
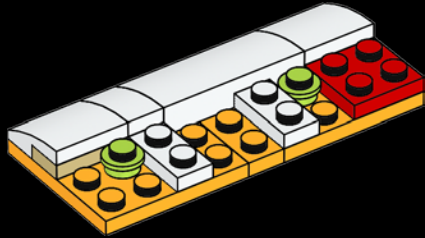

17

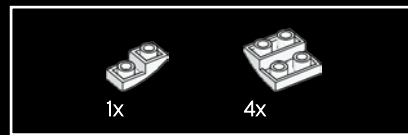
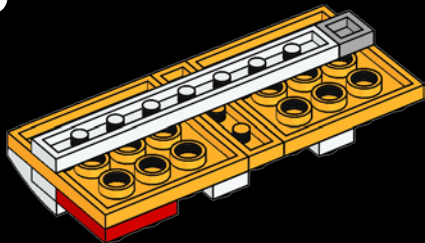

18

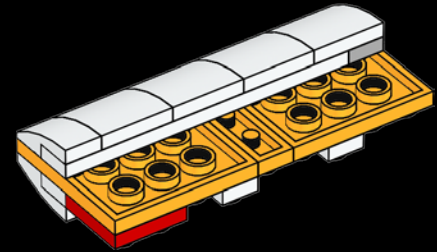

19

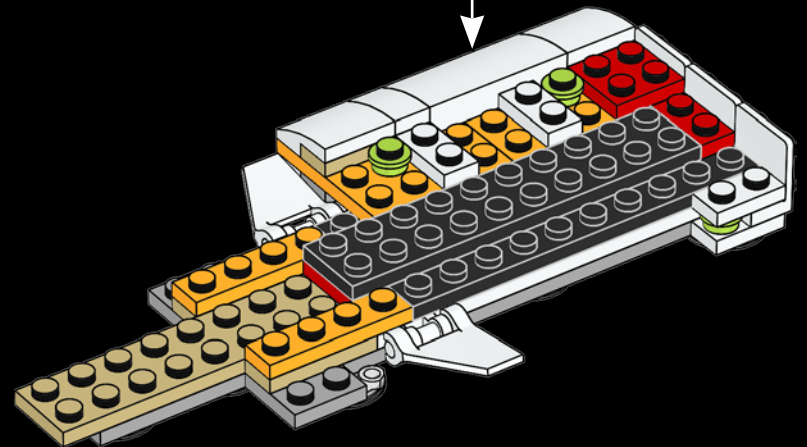

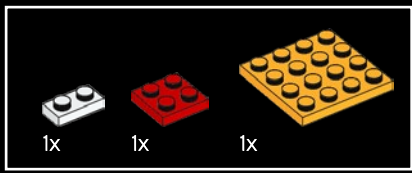

20

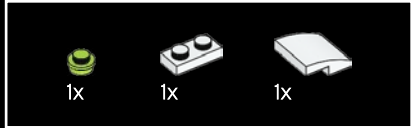

21

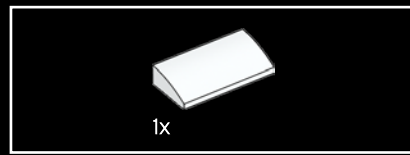

22

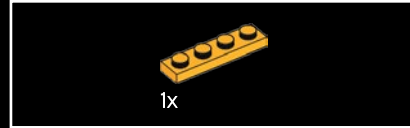

23

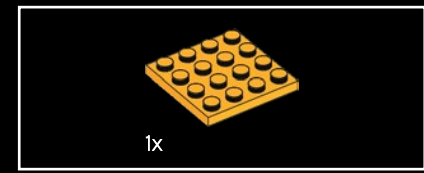
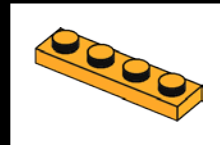

24

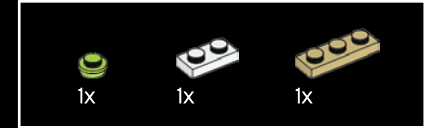
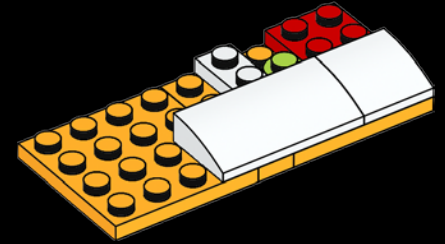

25

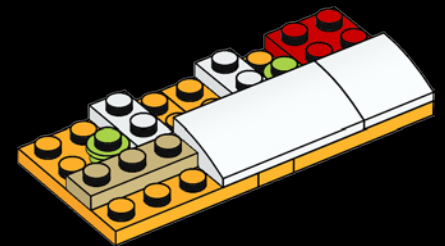

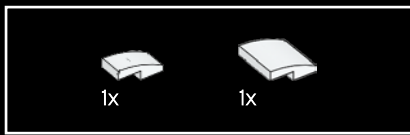

26

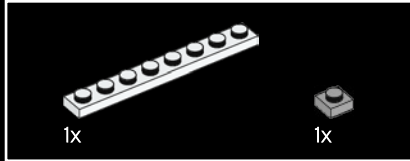
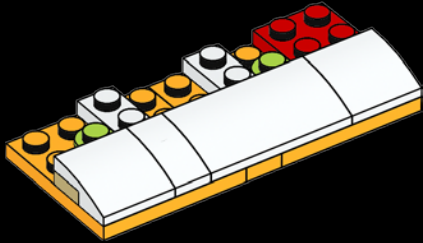

27

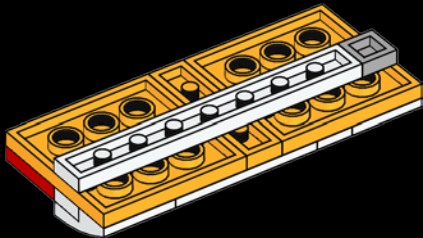

28

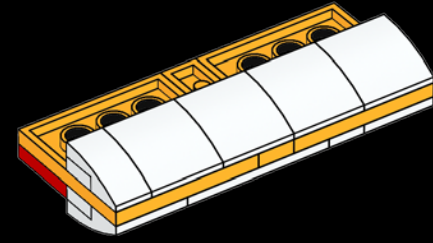

29

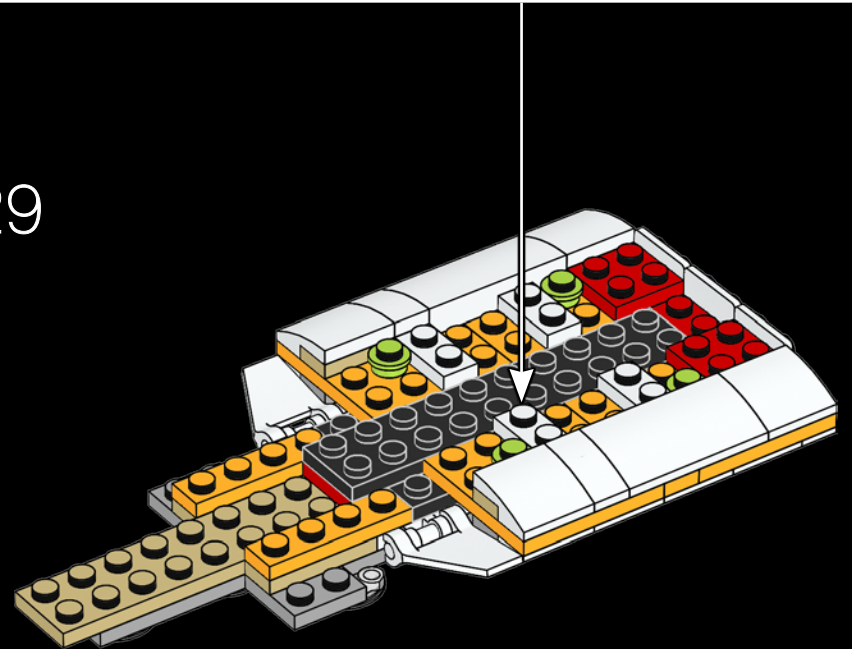

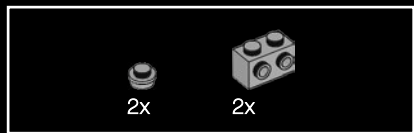

30

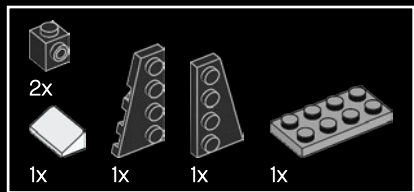
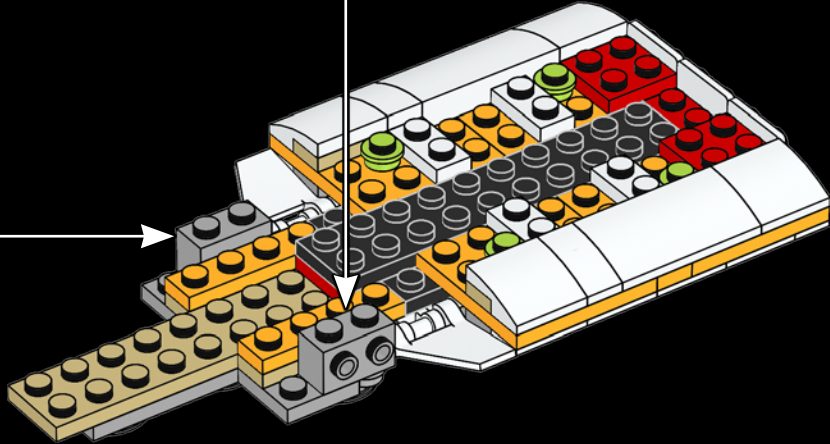
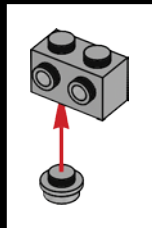
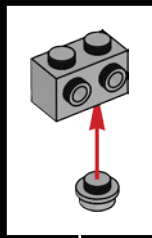

31

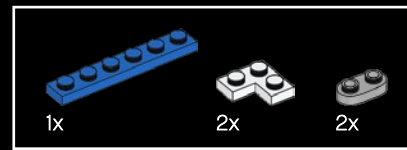
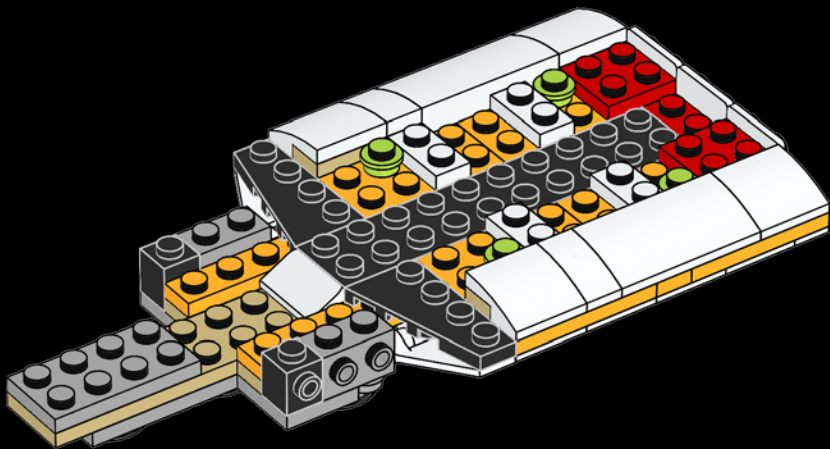

32

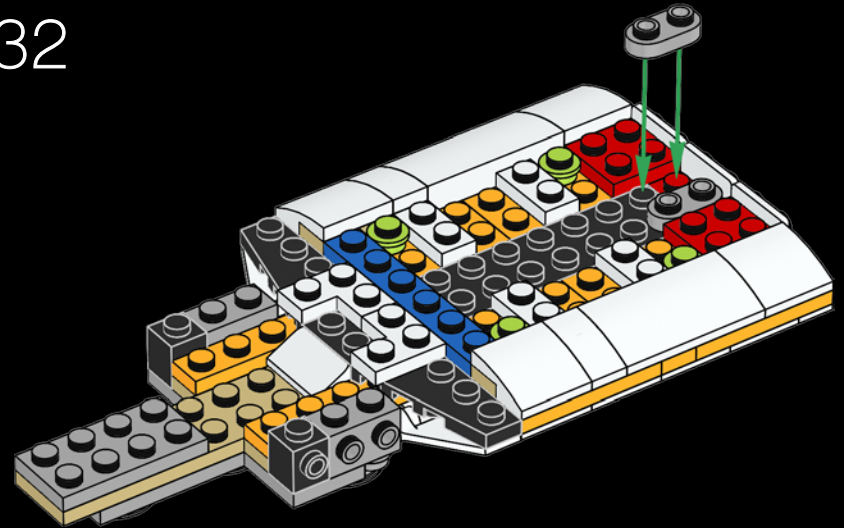

33

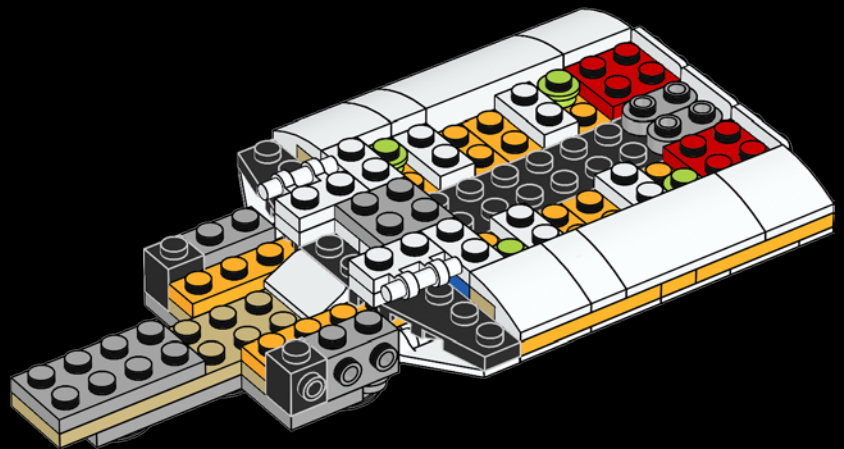

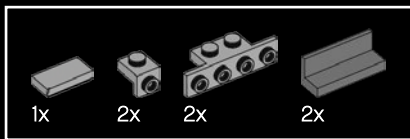

34

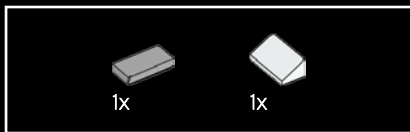
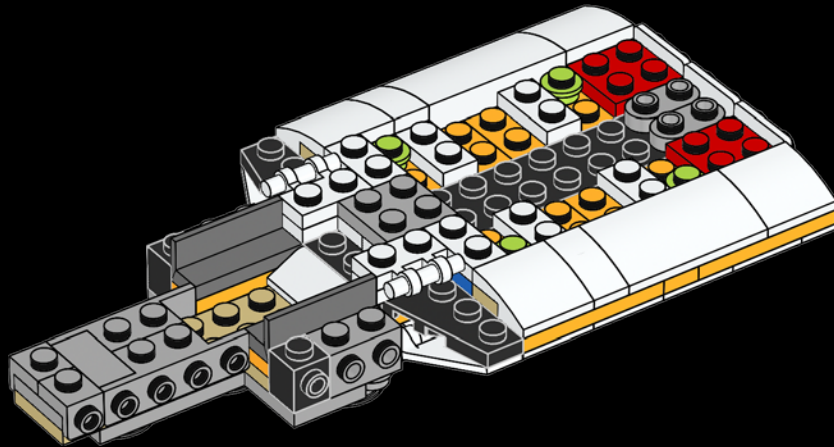

35

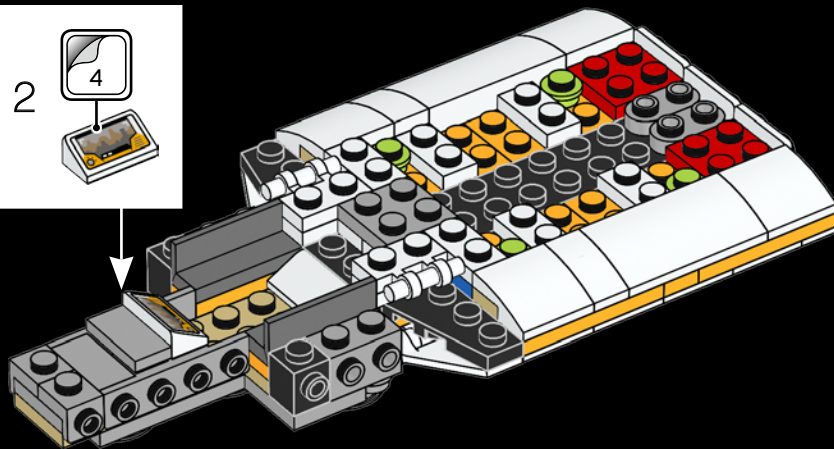
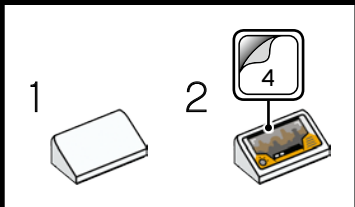

36

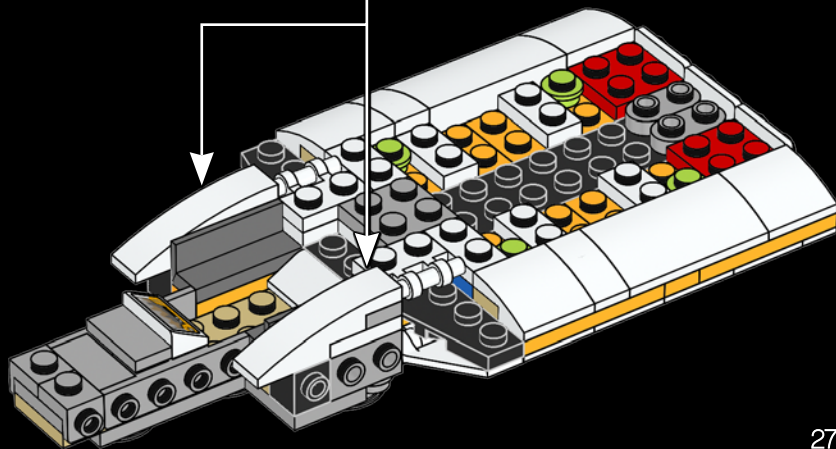
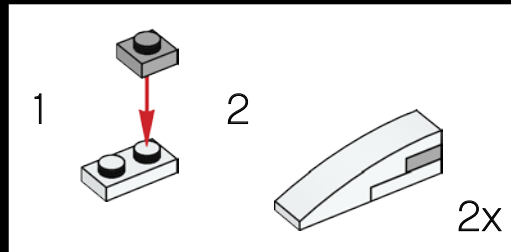

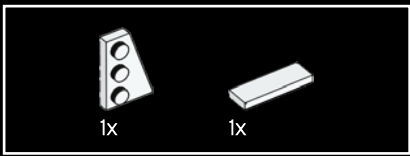

37

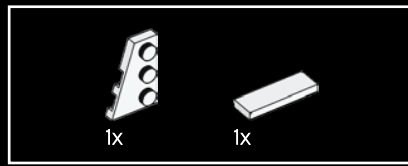
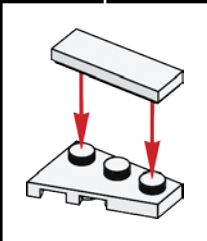
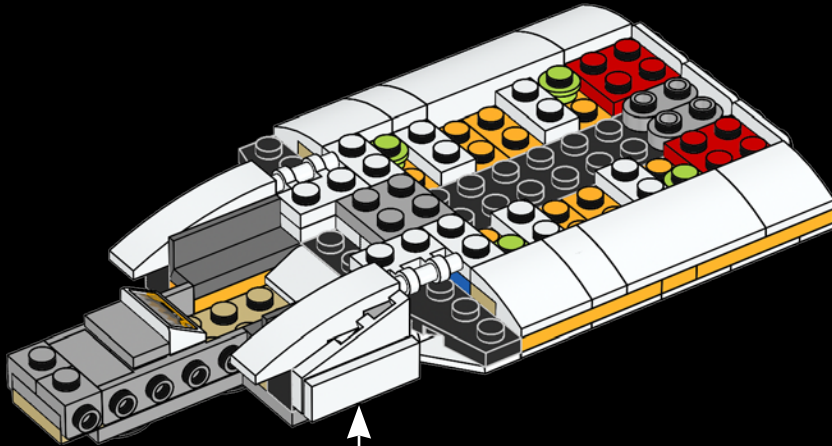

38

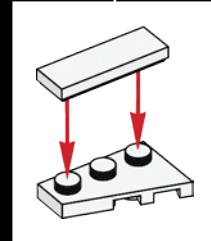
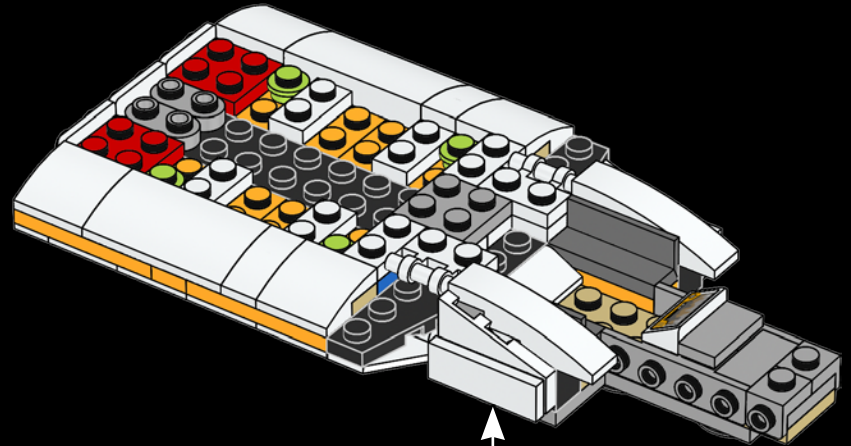

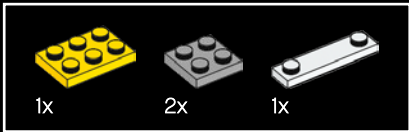
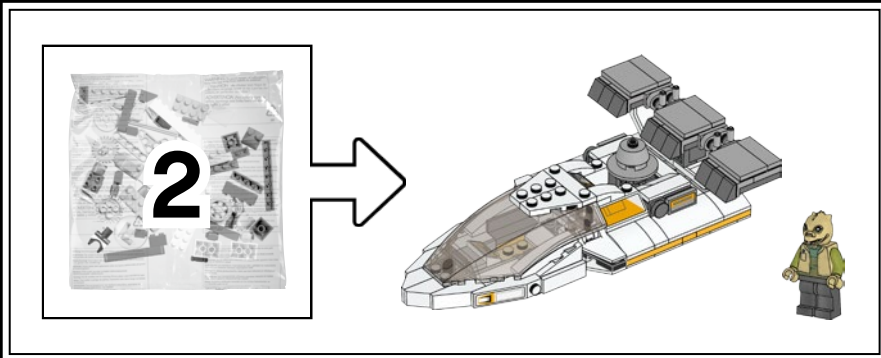

39

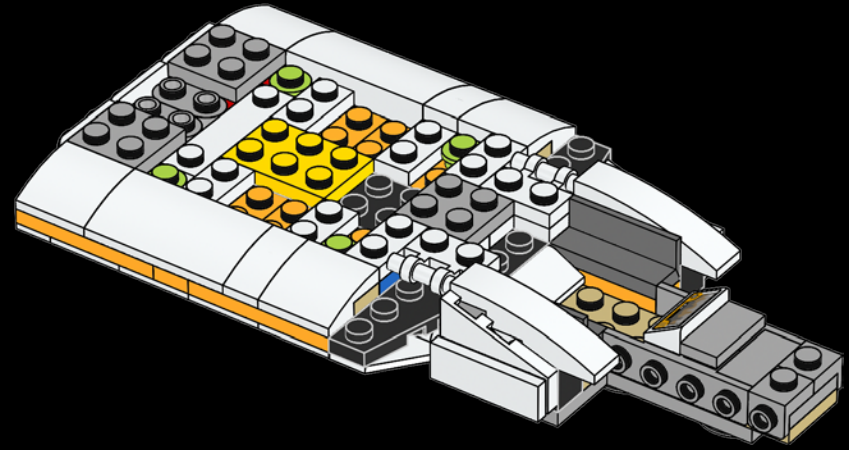
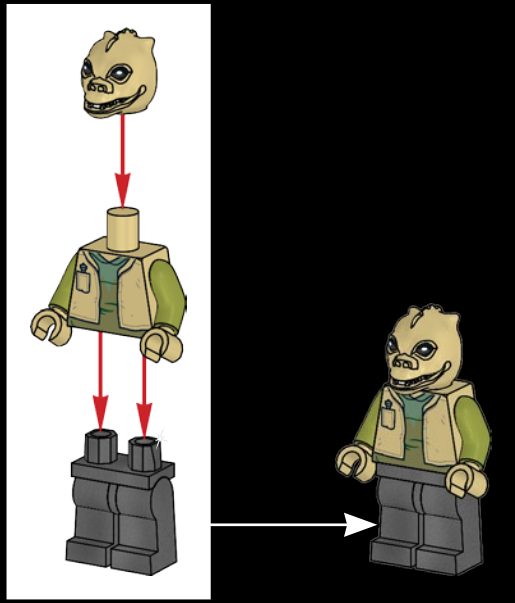

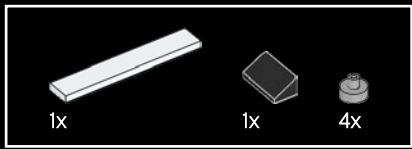

40

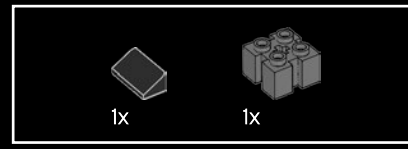
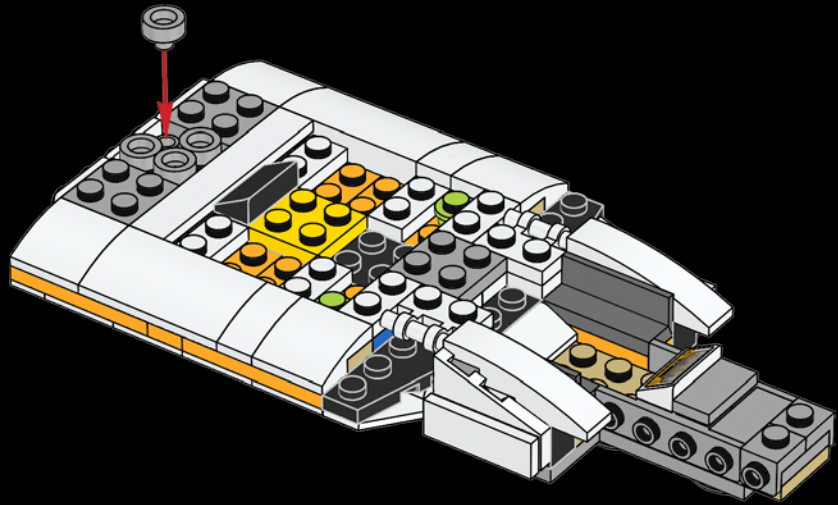

41

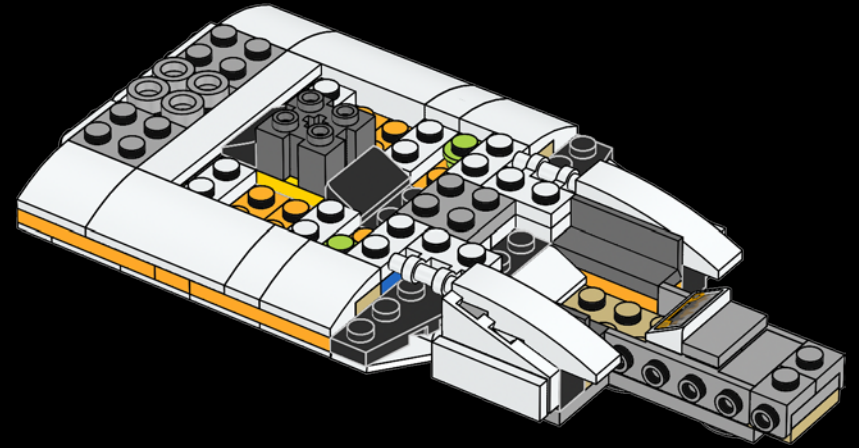

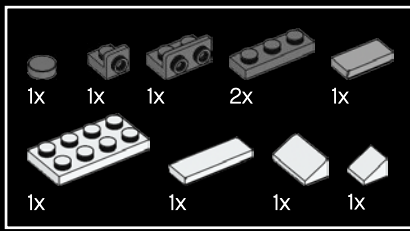

42

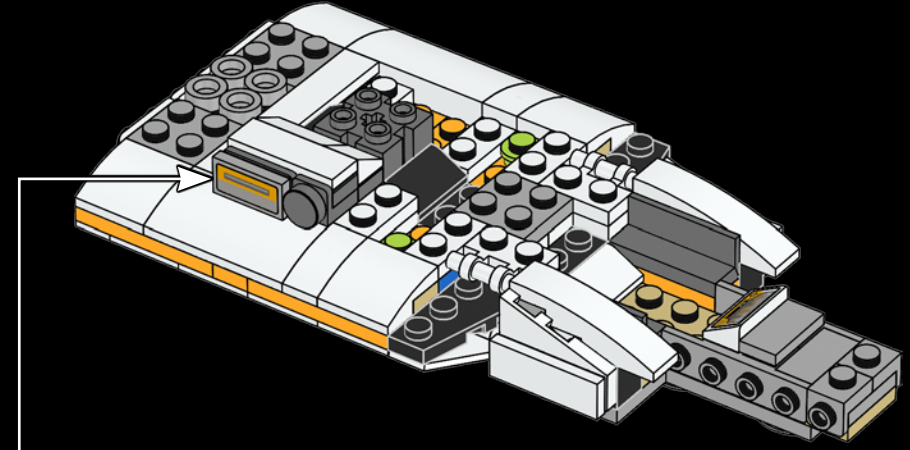
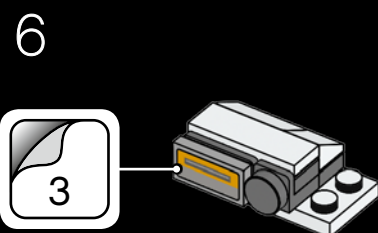
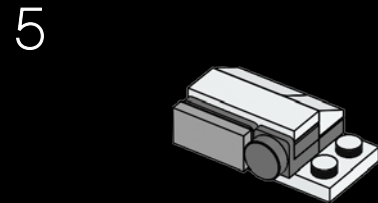
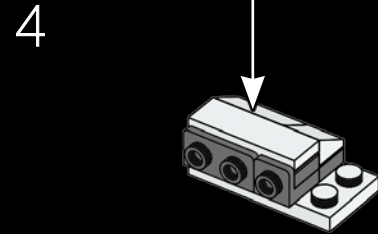
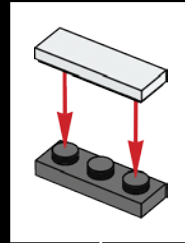
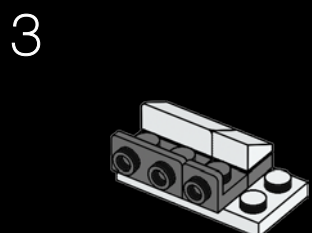
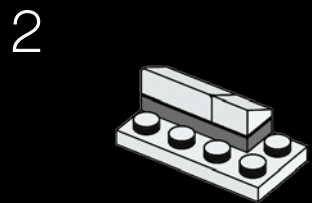
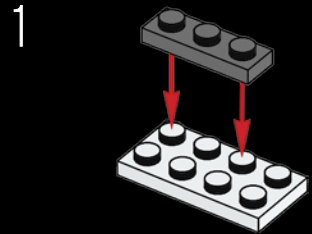

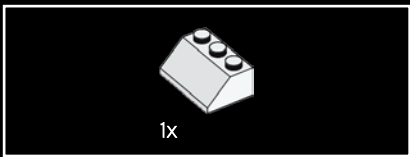

43

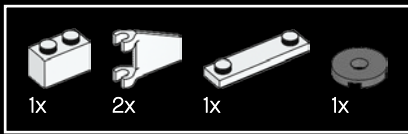
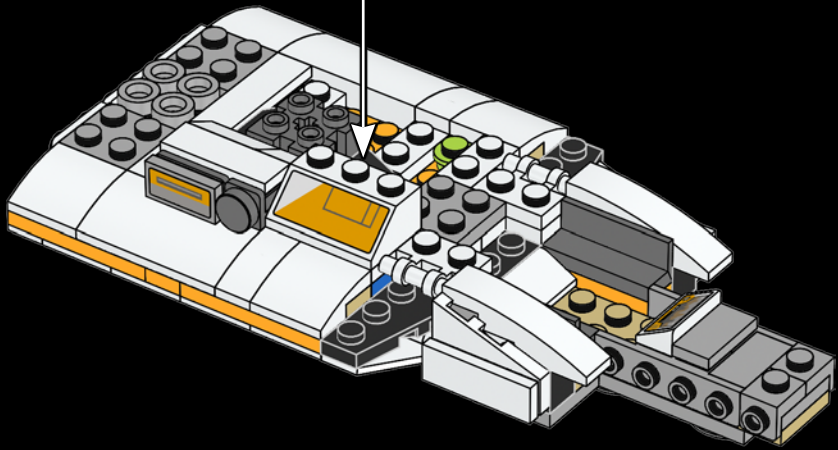
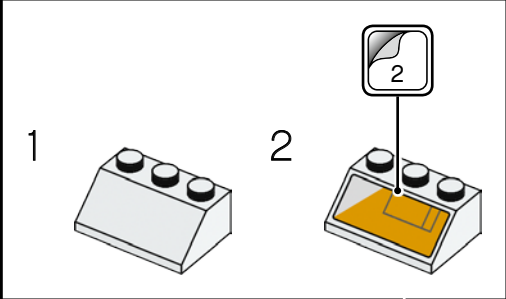

44

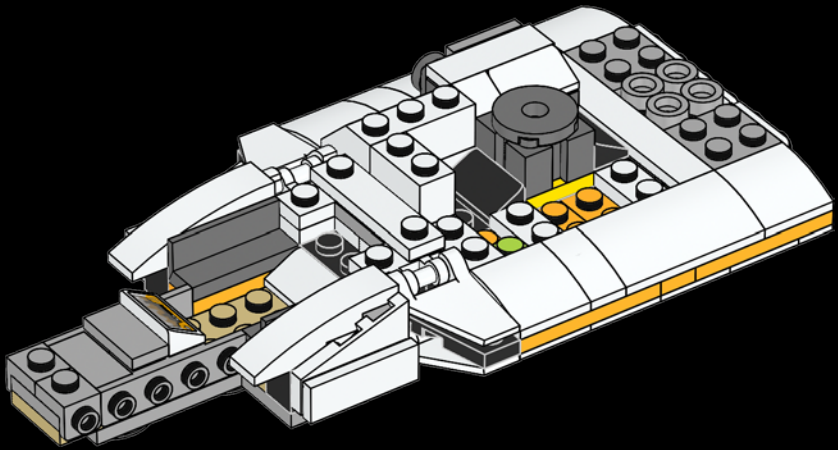

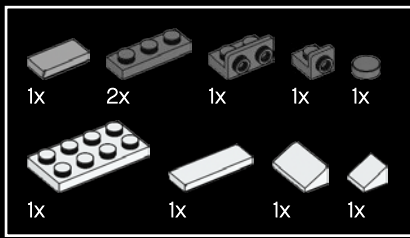

45

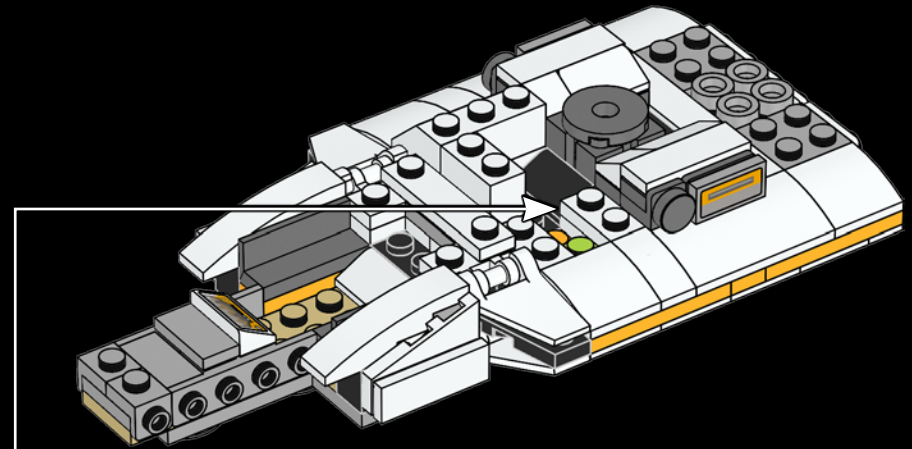
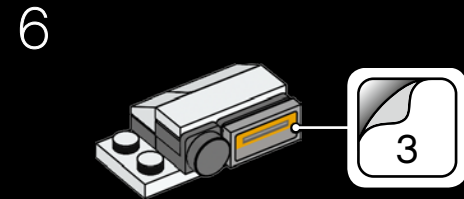
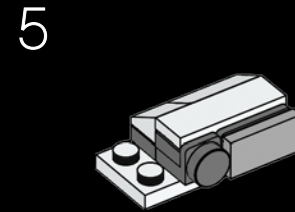
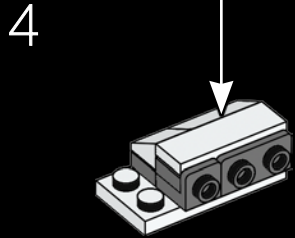
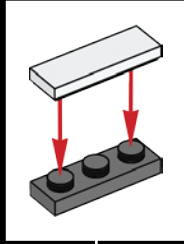
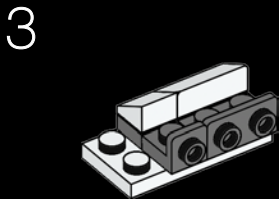
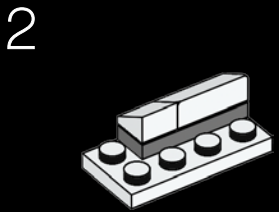
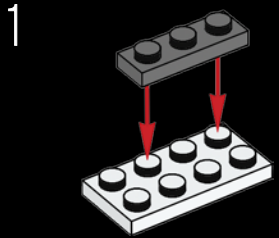

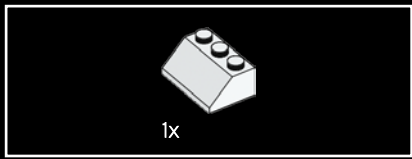

46

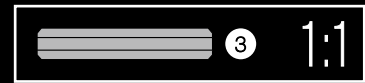
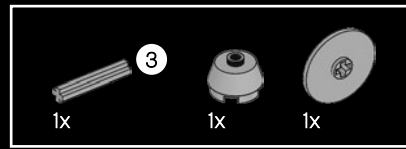
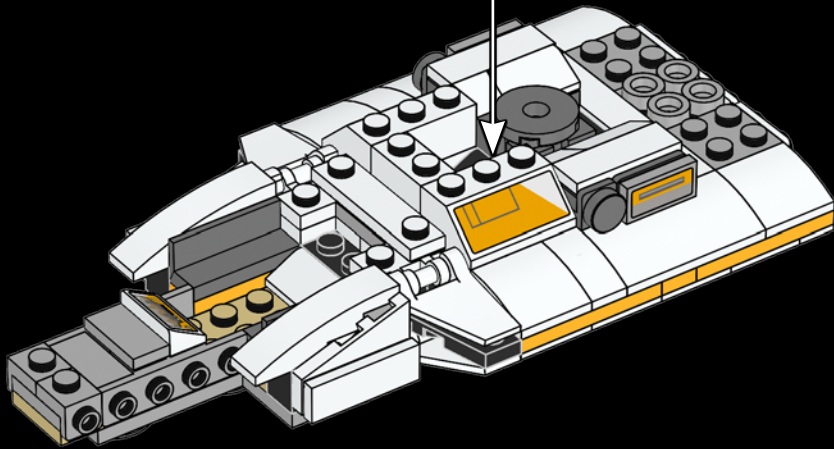
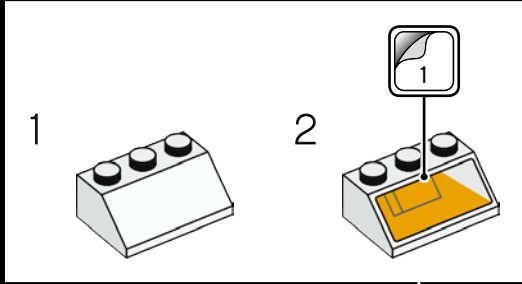

47

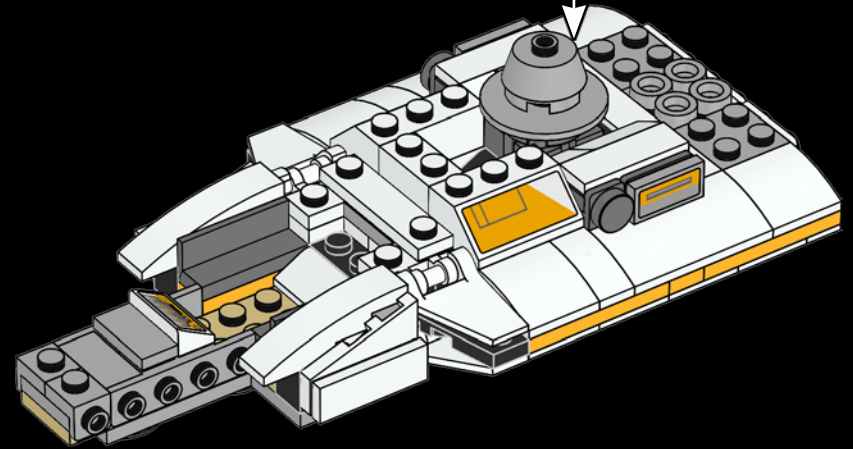
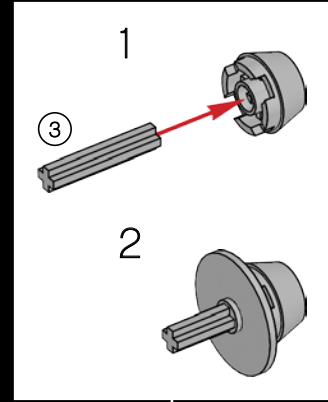

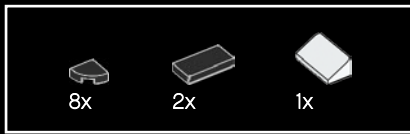

48

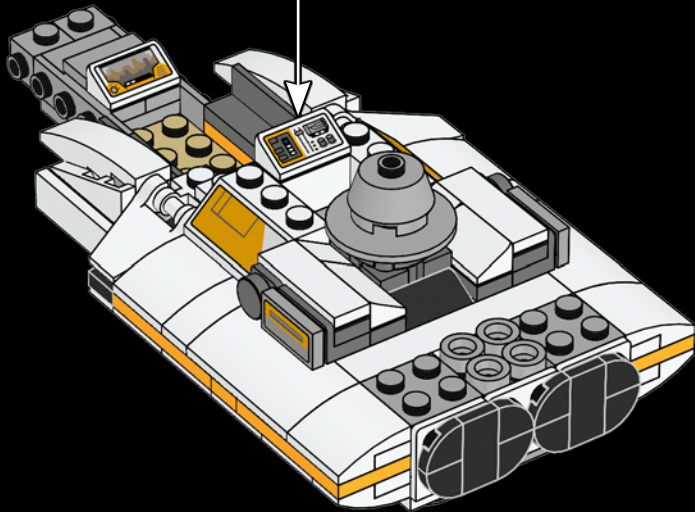
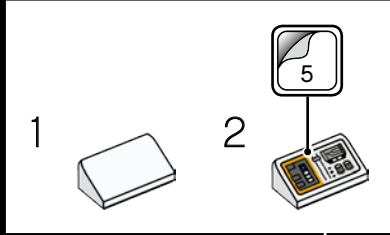

49

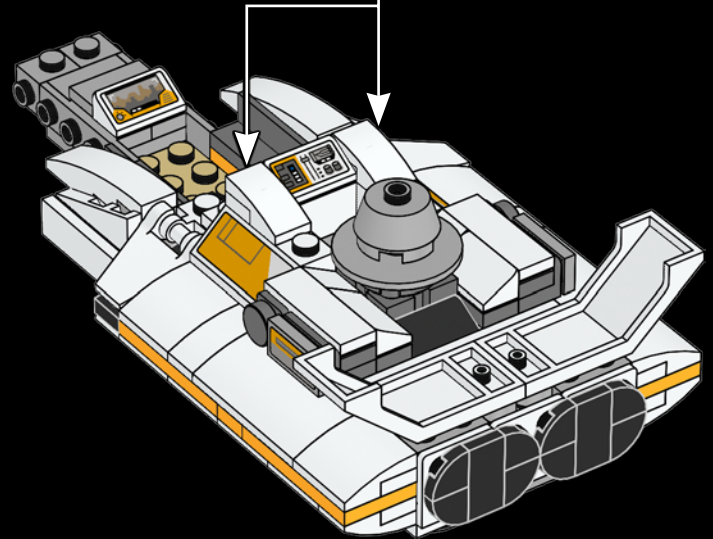
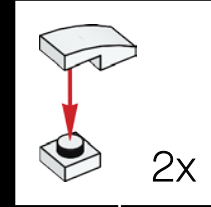

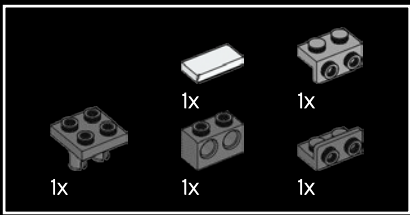

50

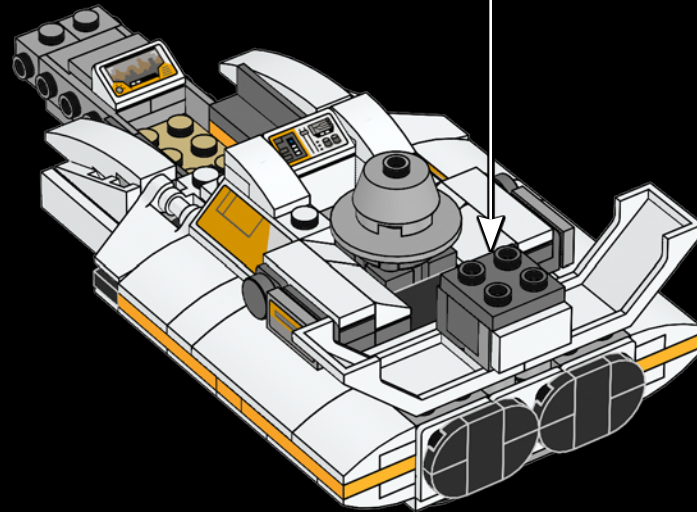
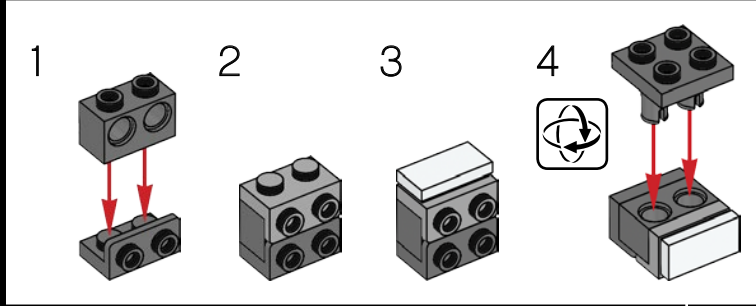

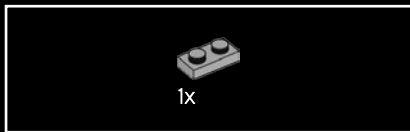
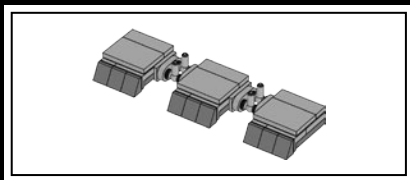

51

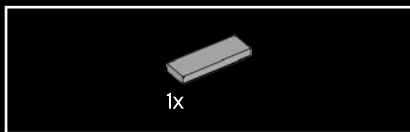

52

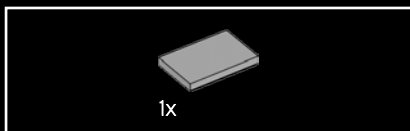
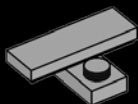

53

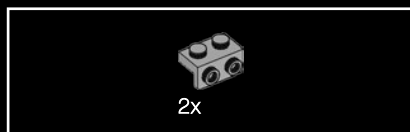
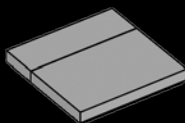

54

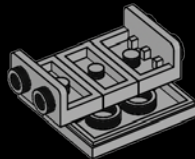

55

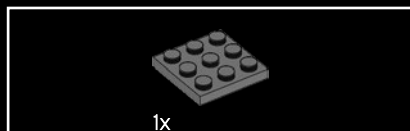
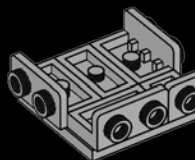

56

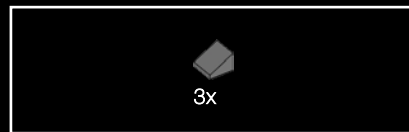
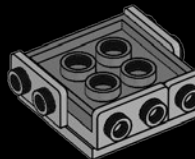

57

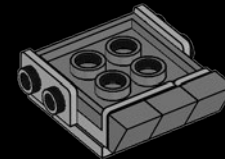

58

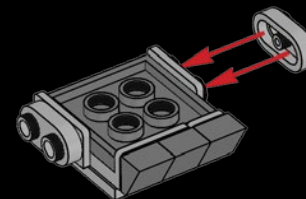

59

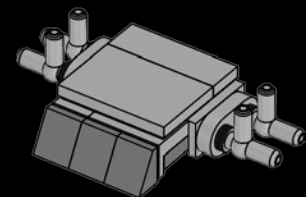

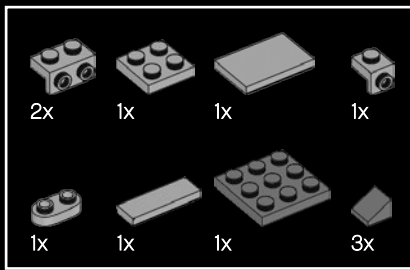

60

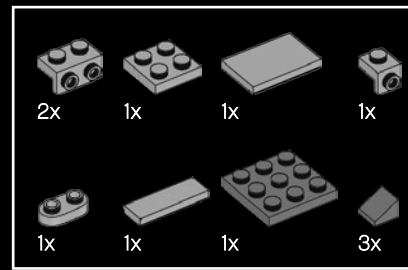
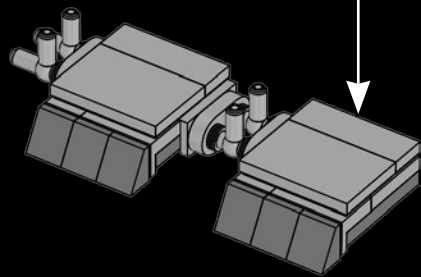
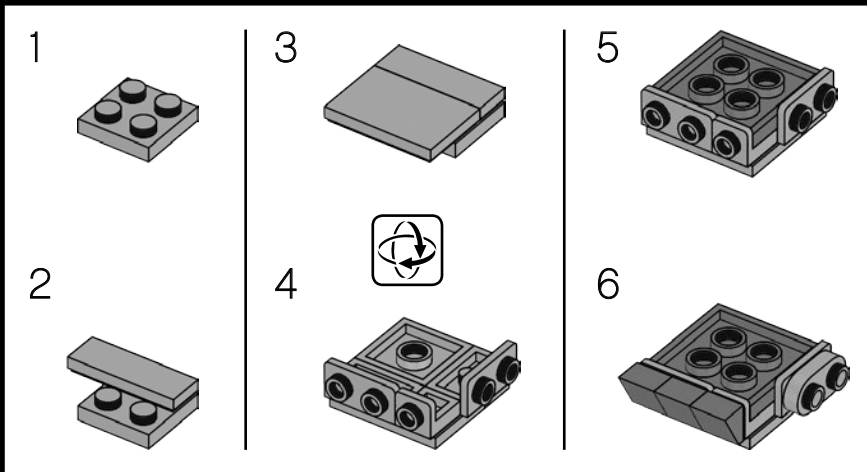

61

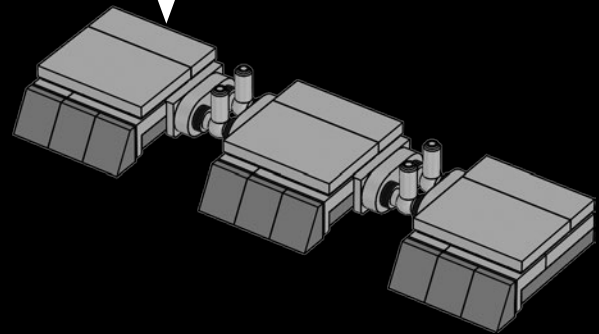
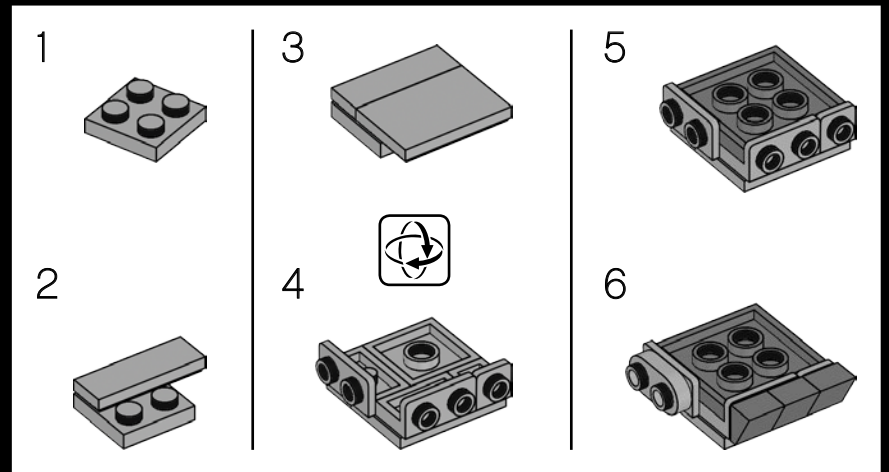

62

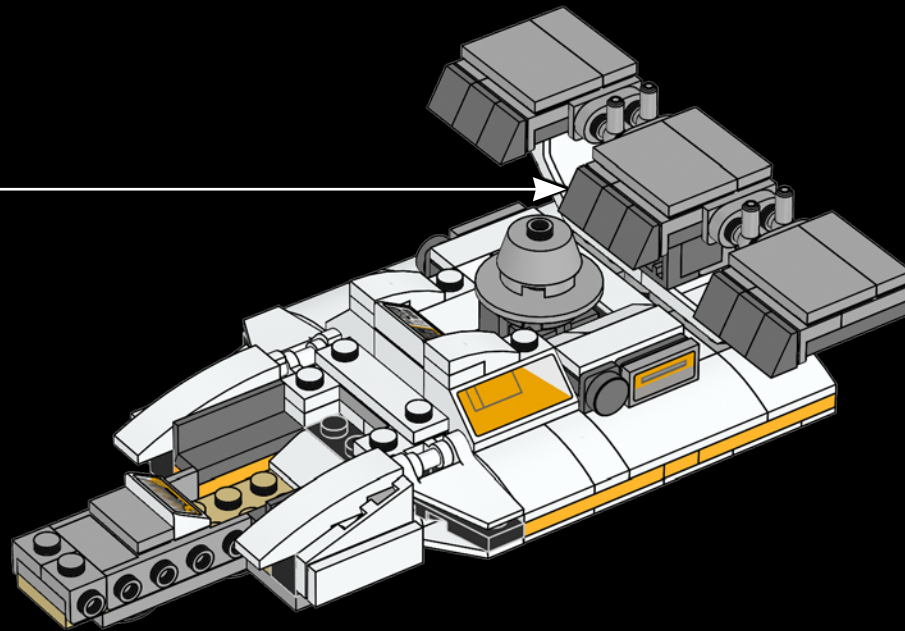

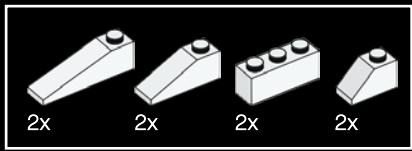

63

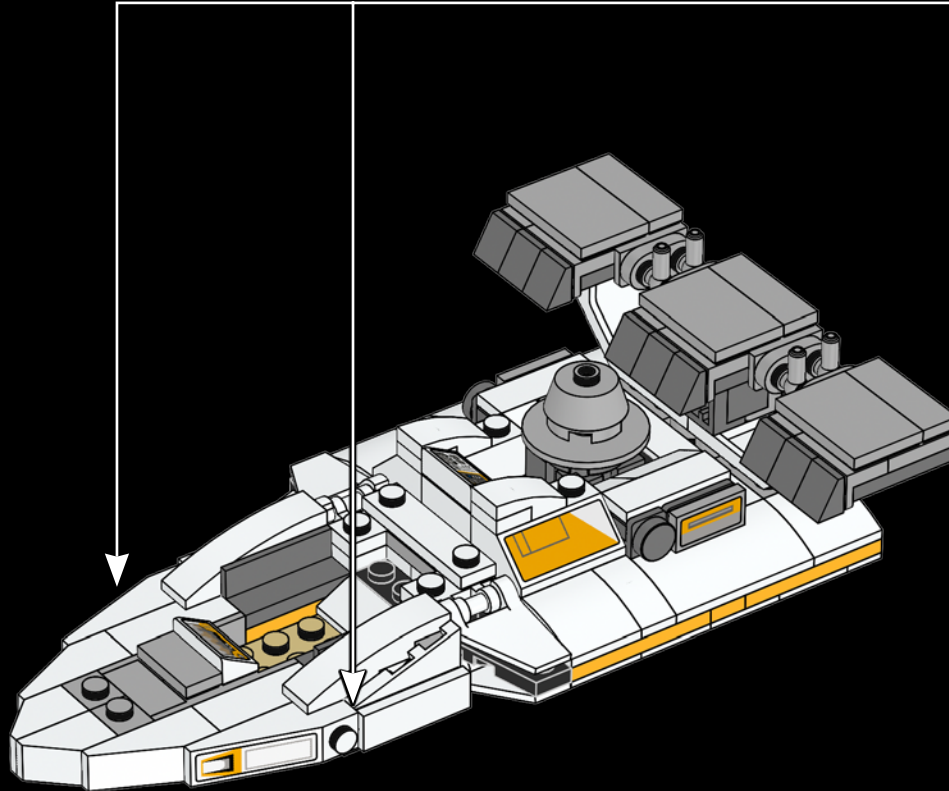
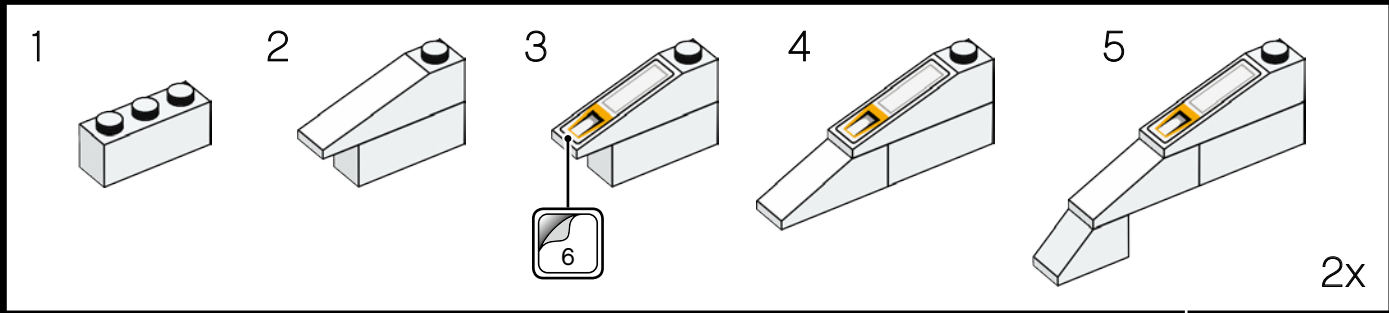

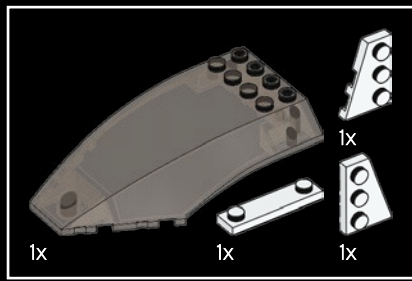

64

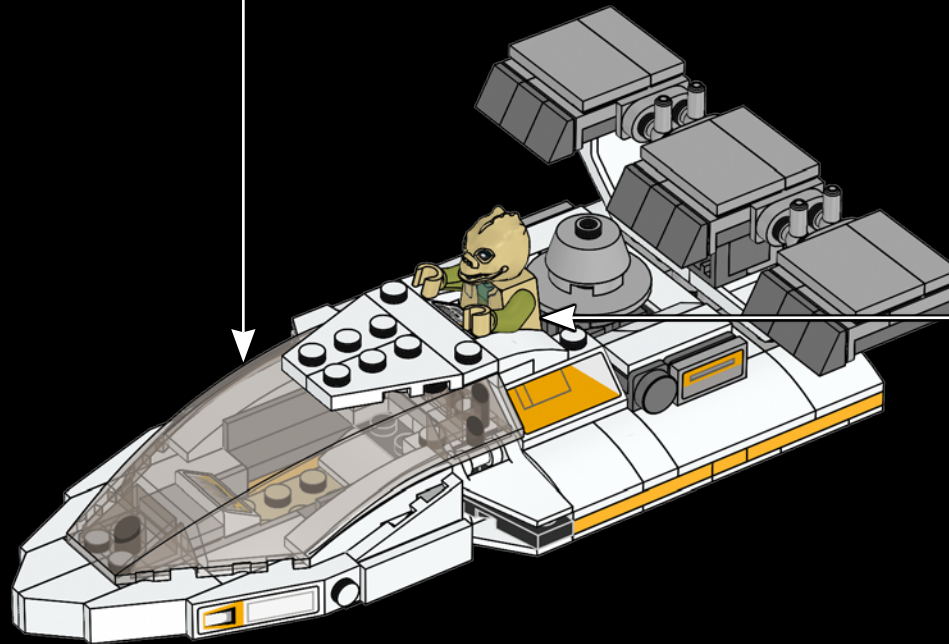
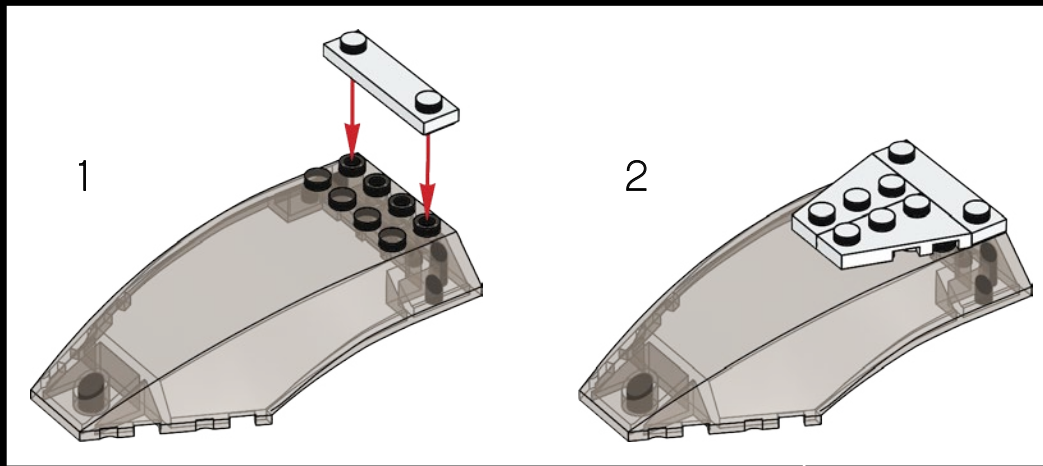



© & ™ Lucasfilm Ltd.

THE CANTINA BUILDING

When you slide the Cantina building open and lift off the roof, you get a clear view of the cavern mayhem inside. From the bar with Wuher the bartender to the booth where Obi-Wan Kenobi, Luke Skywalker, Han Solo and Chewbacca strike the deal to go to Alderaan, and everything in between.

Enter through the sliding front door and try to smuggle R2-D2 and C-3PO past the droid detector. You can decide who shoots first in the booth where Han Solo meets Greedo – just pull the lever to activate the eject button in one of the seats.

And of course, no Cantina scene would be complete without the Bith band Figrin D'an and the Modal Nodes.

LE BÂTIMENT DE LA CANTINA

Lorsque vous ouvrez le bâtiment de la cantina et soulevez le toit, vous pouvez bien voir le chaos qui règne dans la taverne. Les détails sont nombreux, allant du bar avec Wuher le barman jusqu'à la table où Obi-Wan Kenobi, Luke Skywalker, Han Solo et Chewbacca concluent leur accord pour se rendre à Alderaan, et bien plus encore.

Entrez par la porte d'entrée coulissante et essayez de faire passer R2-D2 et C-3PO en évitant le détecteur de droïdes. Vous pouvez décider qui tirera en premier à la table où Han Solo rencontre Greedo; il suffit de tirer le levier pour actionner le bouton d'éjection dans l'un des sièges.

Et bien sûr, la scène de la cantina ne serait pas complète sans le groupe de musique Bith, Figrin D'an et les Modal Nodes.



© & ™ Lucasfilm Ltd.



© & ™ Lucasfilm Ltd.

MODELO DE LA CANTINA

No es hasta que abres el modelo de la cantina y levantas el techo que llegas a ver con claridad el antro de caos que hay en su interior. Está todo ahí: desde la barra donde Wuher, el cantinero, sirve las bebidas hasta el privado en el que Obi-Wan Kenobi, Luke Skywalker, Han Solo y Chewbacca cierran el trato para ir a Alderaan.

Atraviesa la puerta delantera deslizable e intenta que R2-D2 y C-3PO no llamen la atención del detector de droïdes. Tú decides quién dispara primero en el privado en el que Han Solo se encuentra con Greedo: solo tienes que jalar la palanca para activar la función de eyección de uno de los asientos.

Y, por supuesto, la escena de la cantina no estaría completa sin el Bith Figrin D'an y su banda, los Modal Nodes.



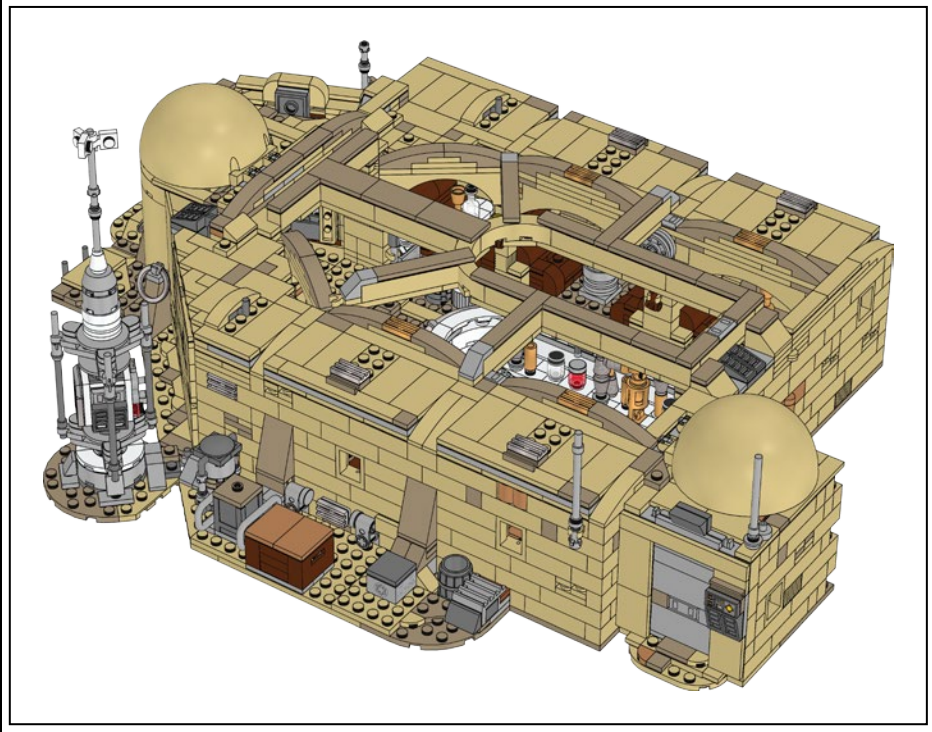
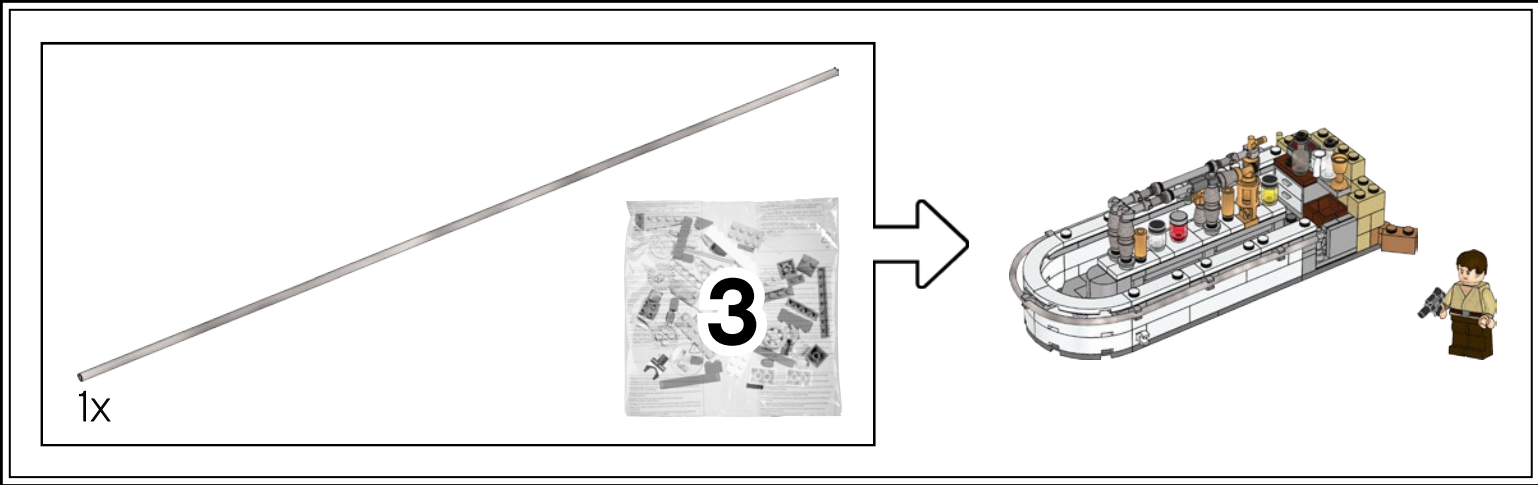

Wuher is the bartender at Chalmun's Cantina, more commonly referred to as The Mos Eisley Cantina. It is a popular watering hole for pilots, smugglers, bounty hunters, and renegades passing through the spaceport.

Wuher est le barman de la cantina de Chalmun, plus communément appelée la cantina de Mos Eisley. Il s'agit d'une taverne populaire pour les pilotes, les contrebandiers, les chasseurs de primes et les renégats qui transitent par l'astroport.

Wuher es el cantinero de la cantina de Chalmun, más comúnmente conocida como Cantina de Mos Eisley. Es un popular abrevadero entre los pilotos, contrabandistas, cazarrecompensas y renegados que pasan por el puerto espacial.

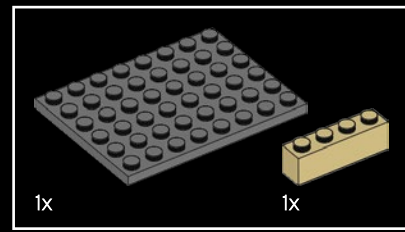
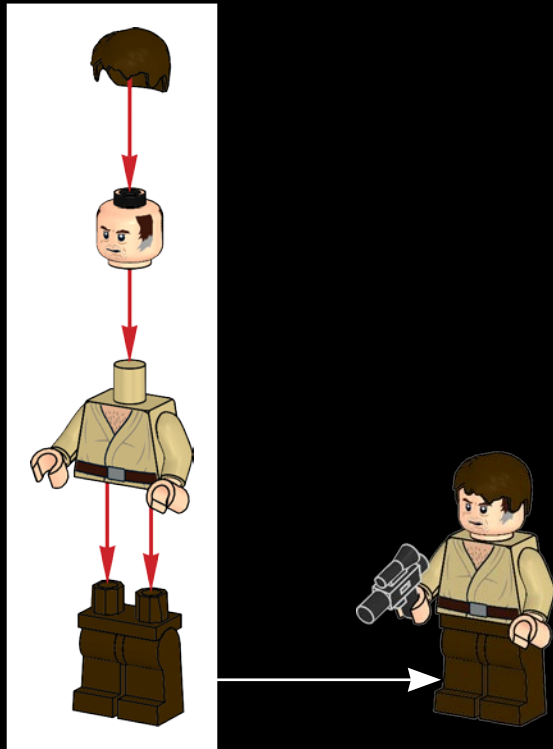

1

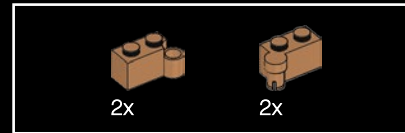
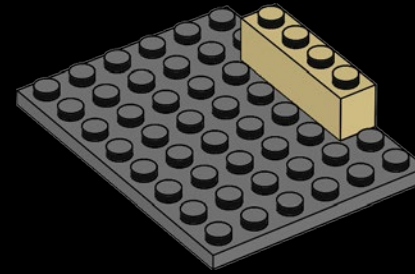

2

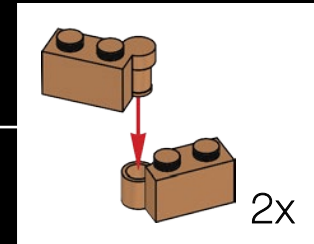
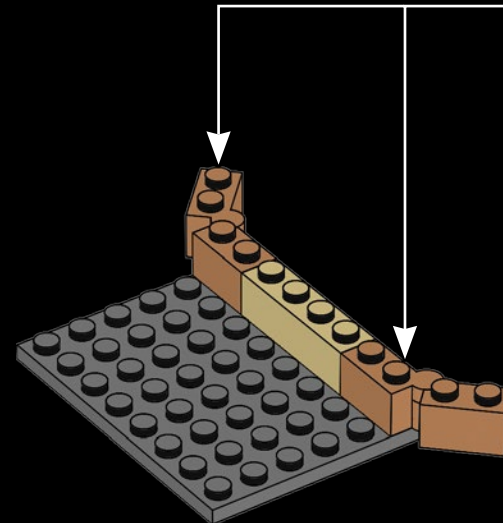

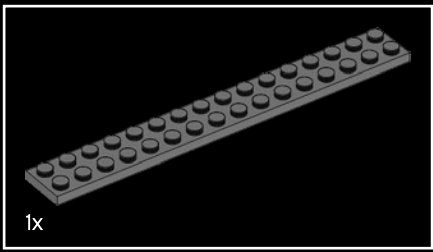

3

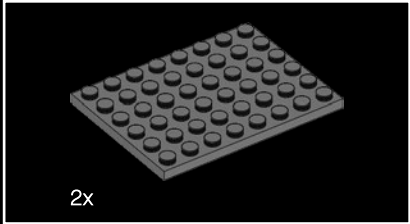
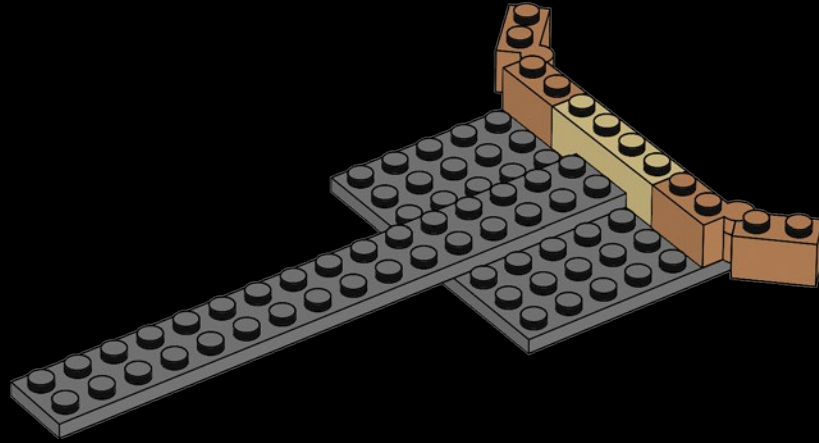

4

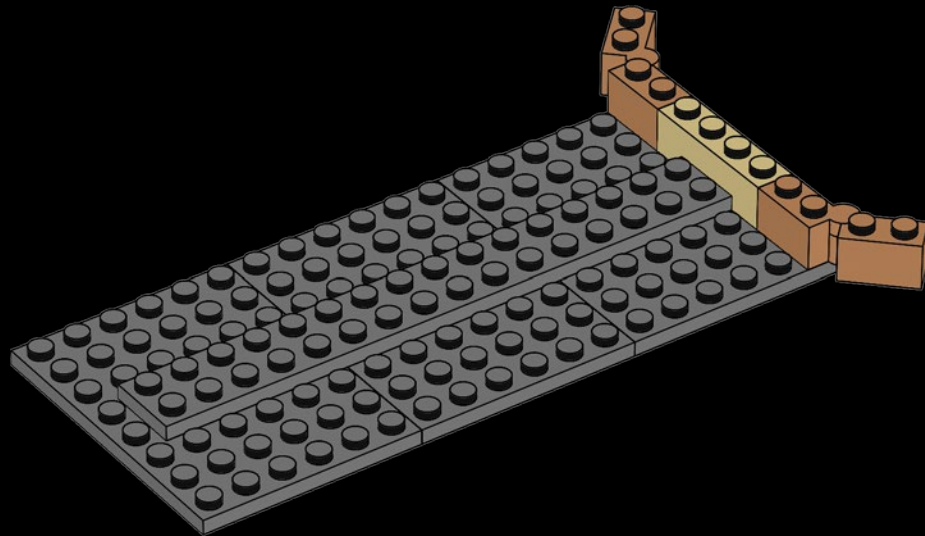



5

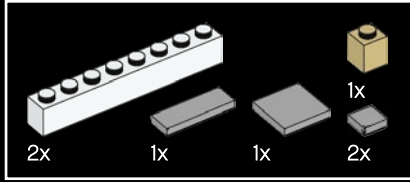
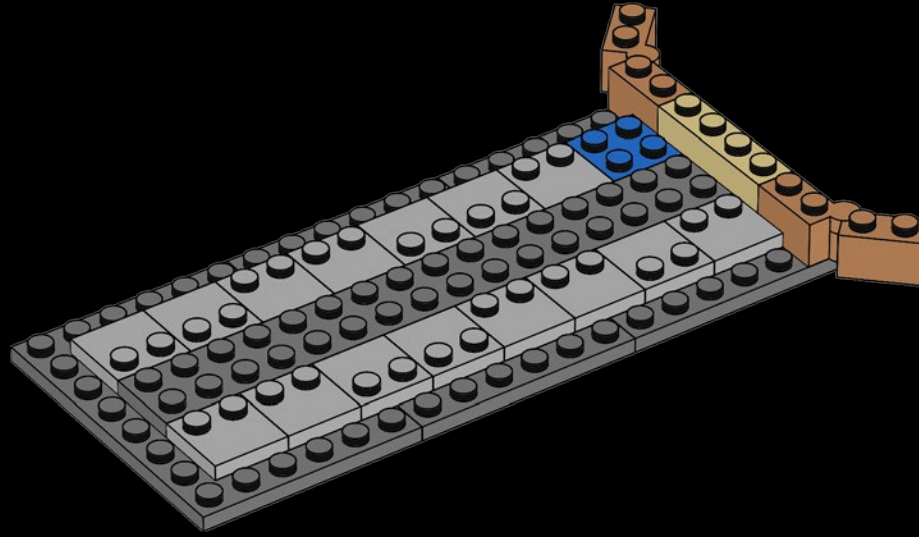

6

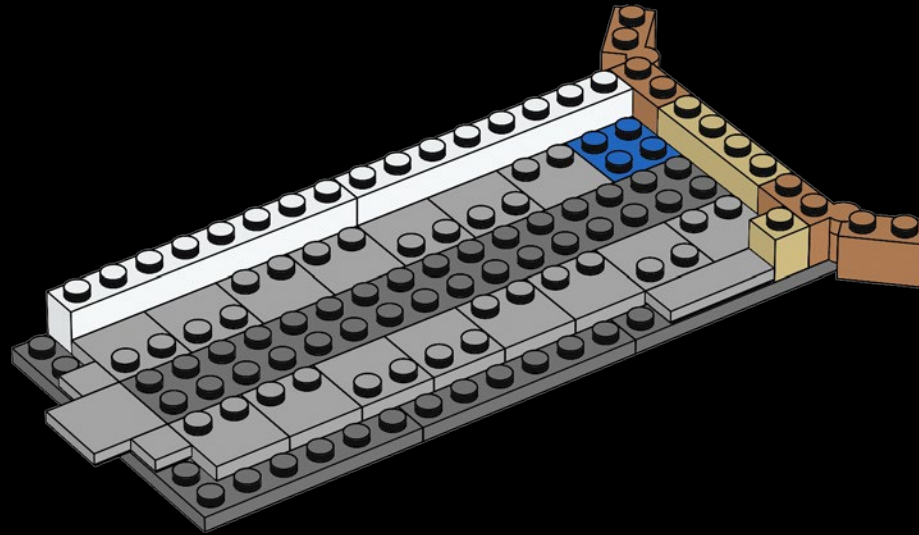

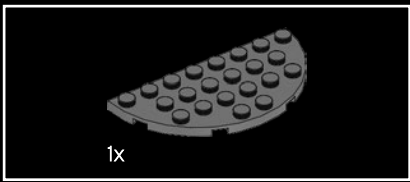

7

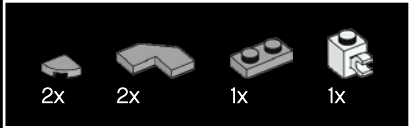
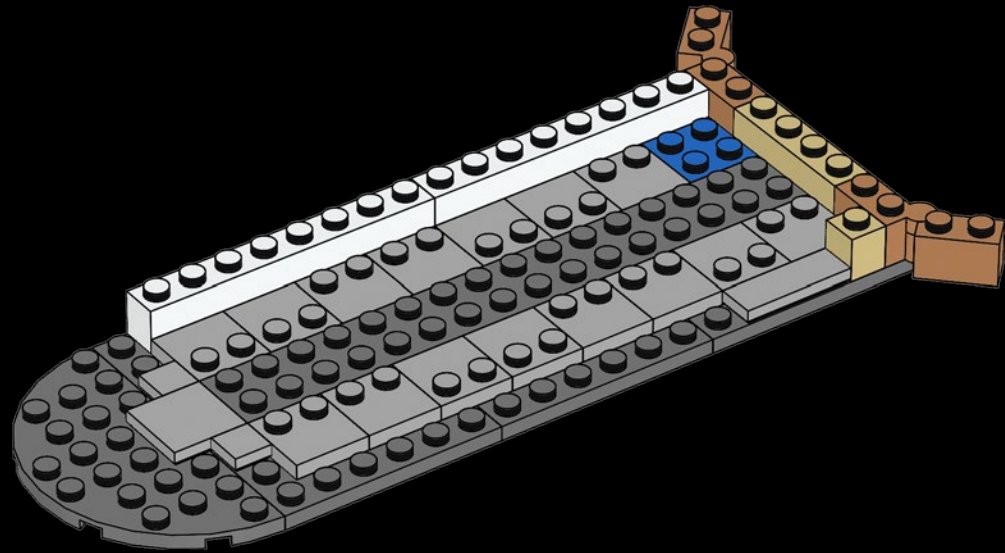

8

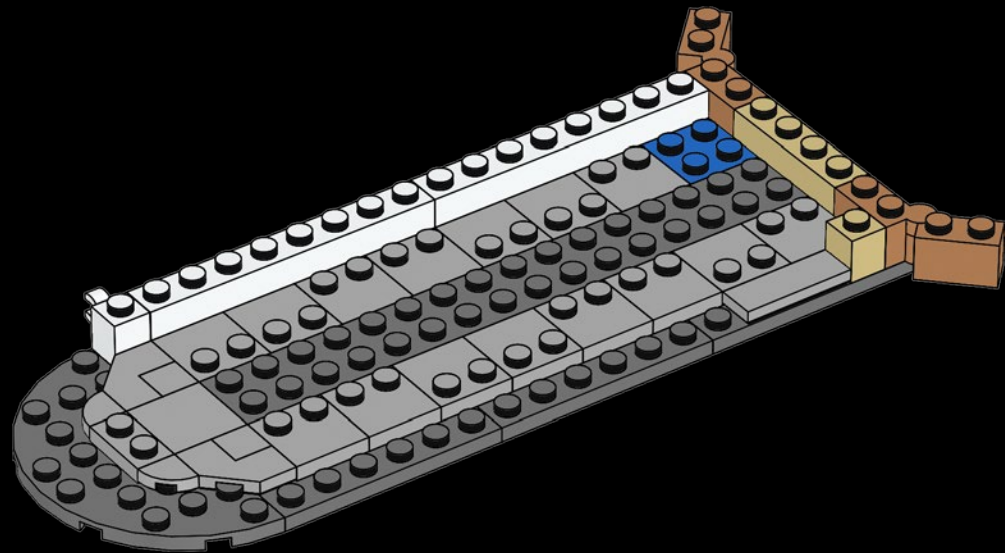

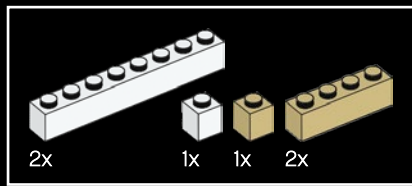

9

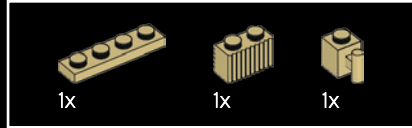
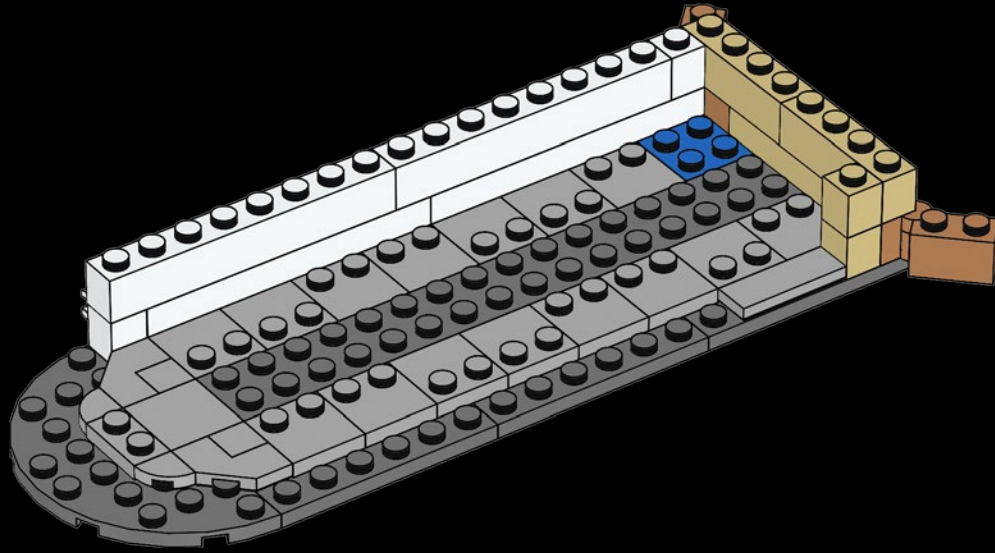

10

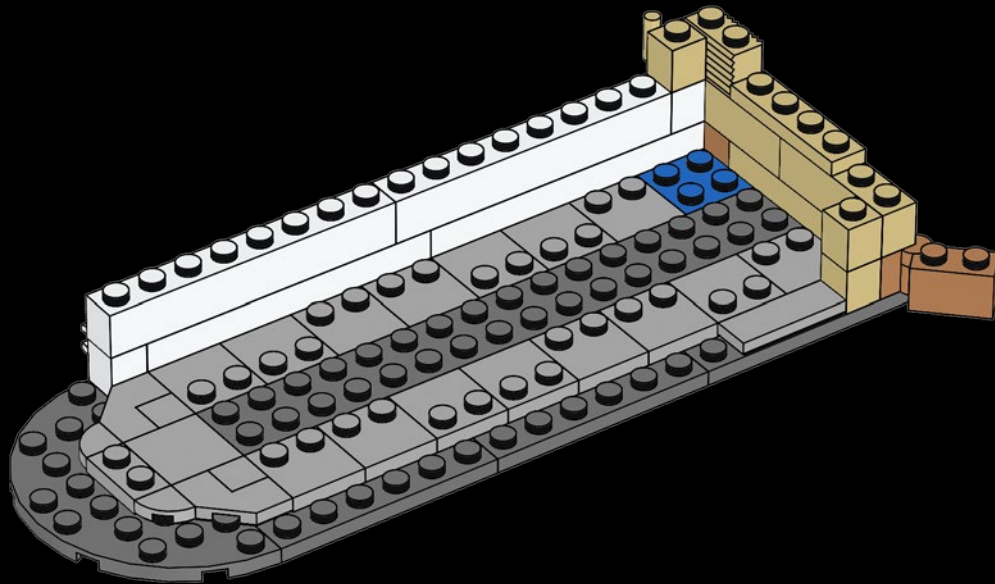

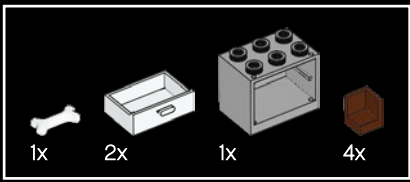

11

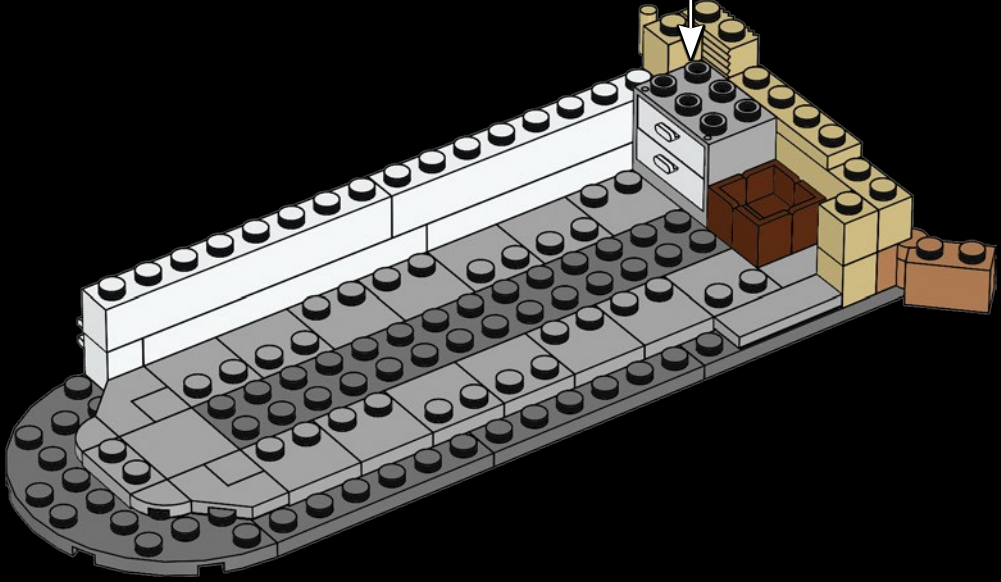
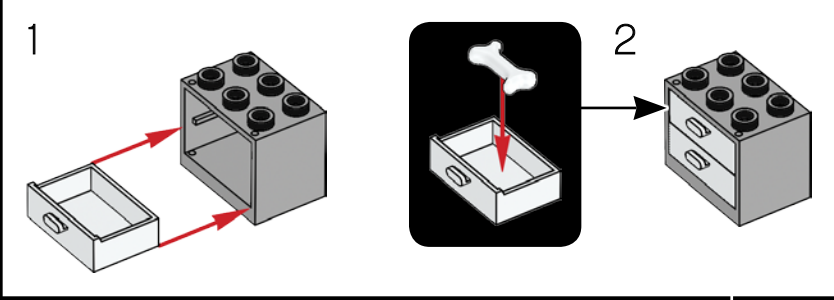



12

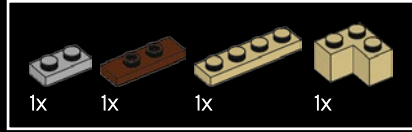
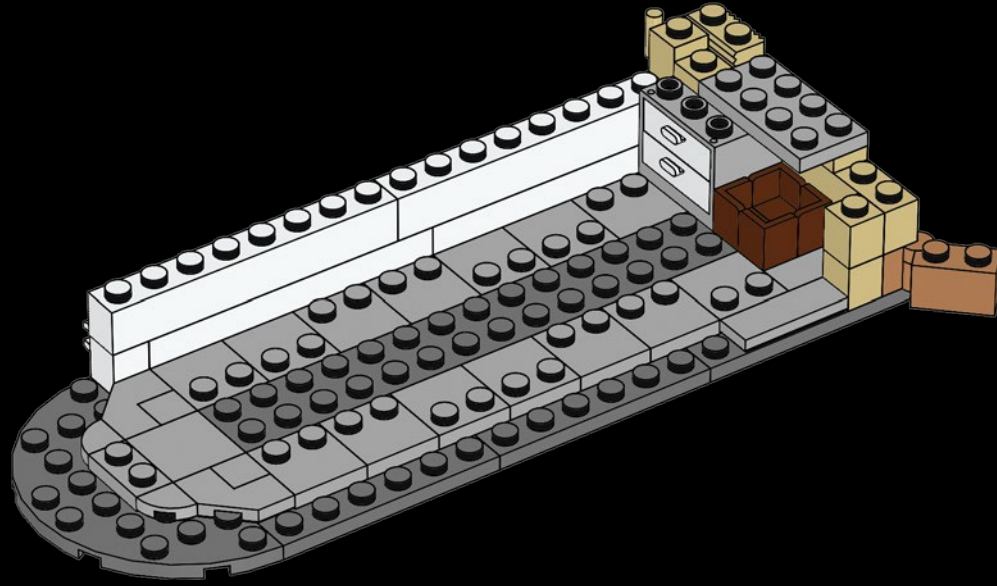

13

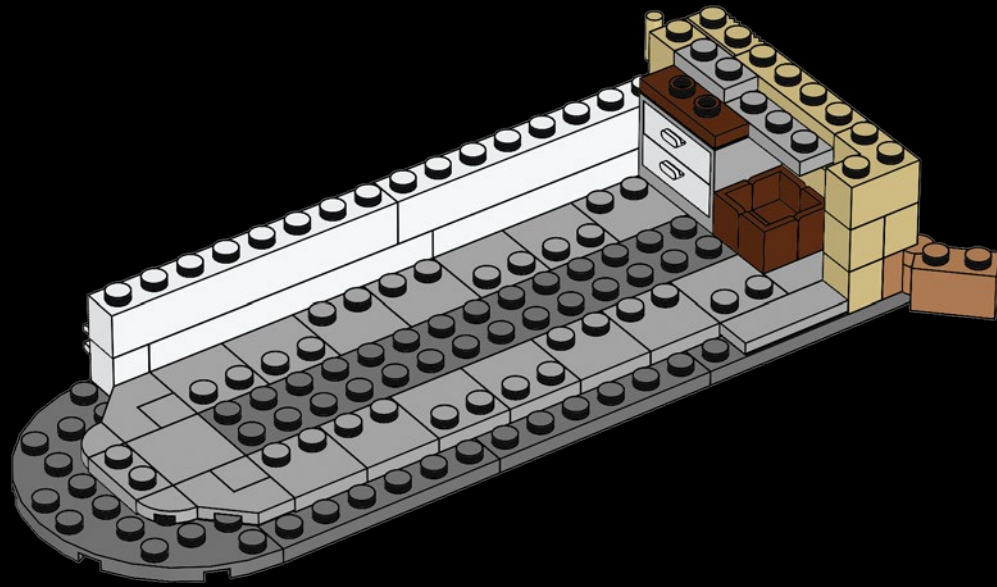

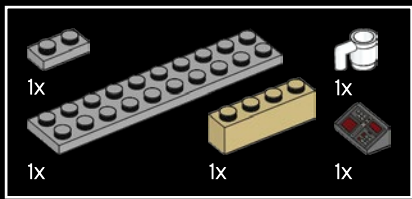

14

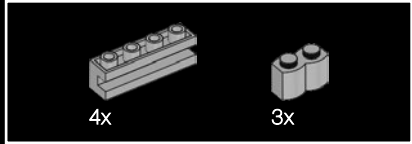
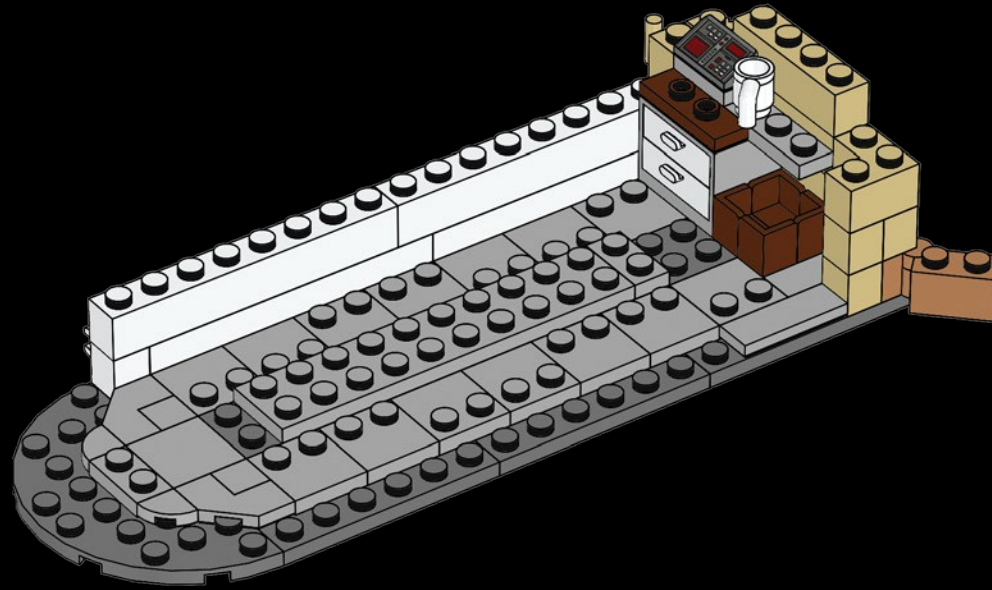

15

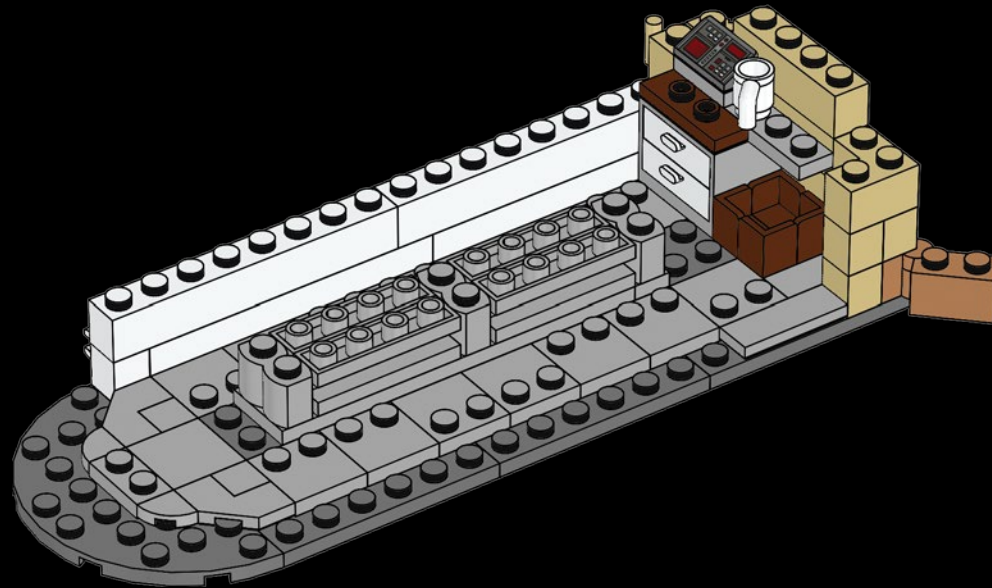

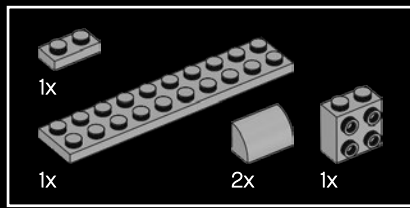

16

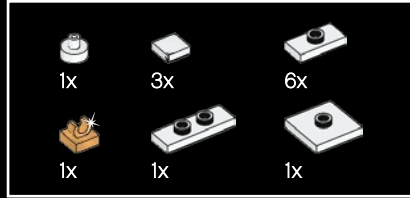
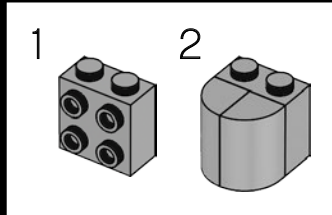
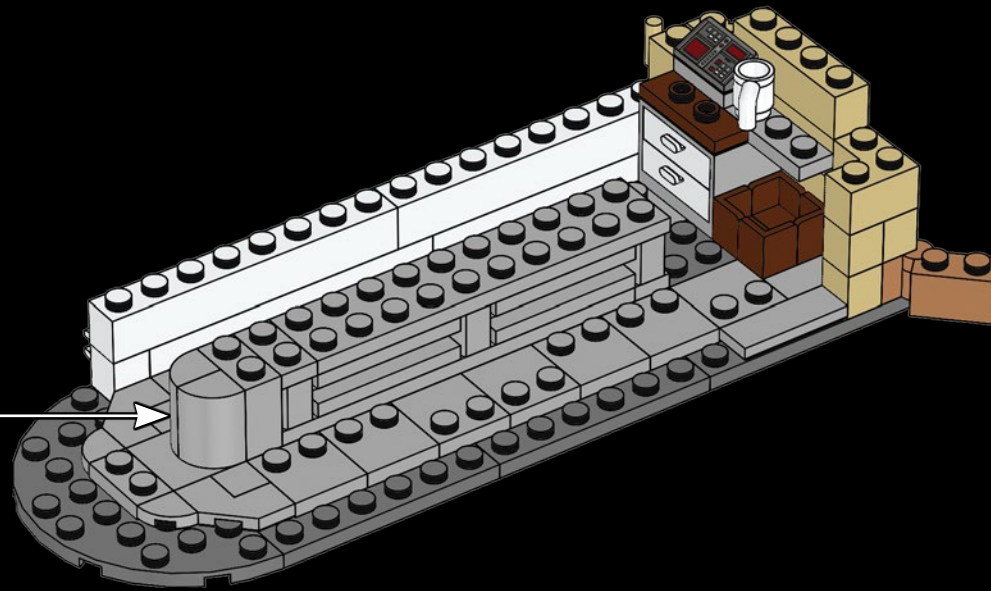

17

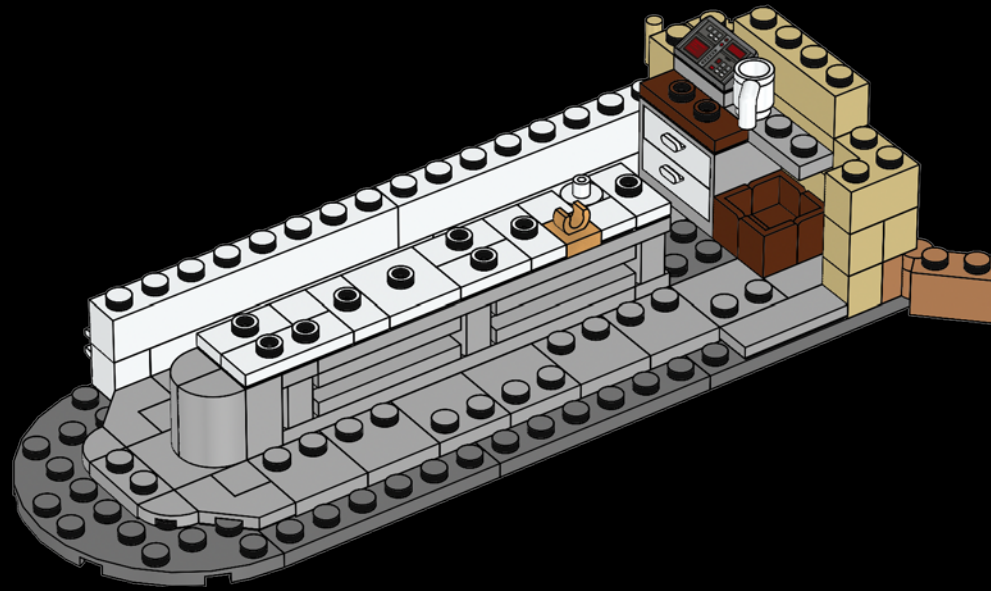

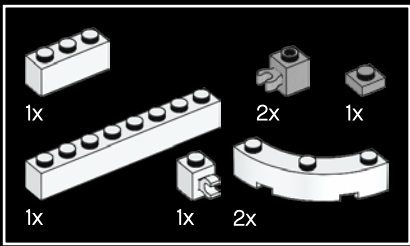

18

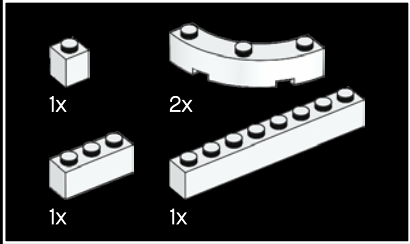
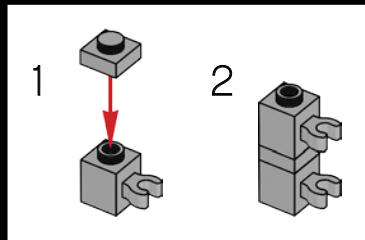
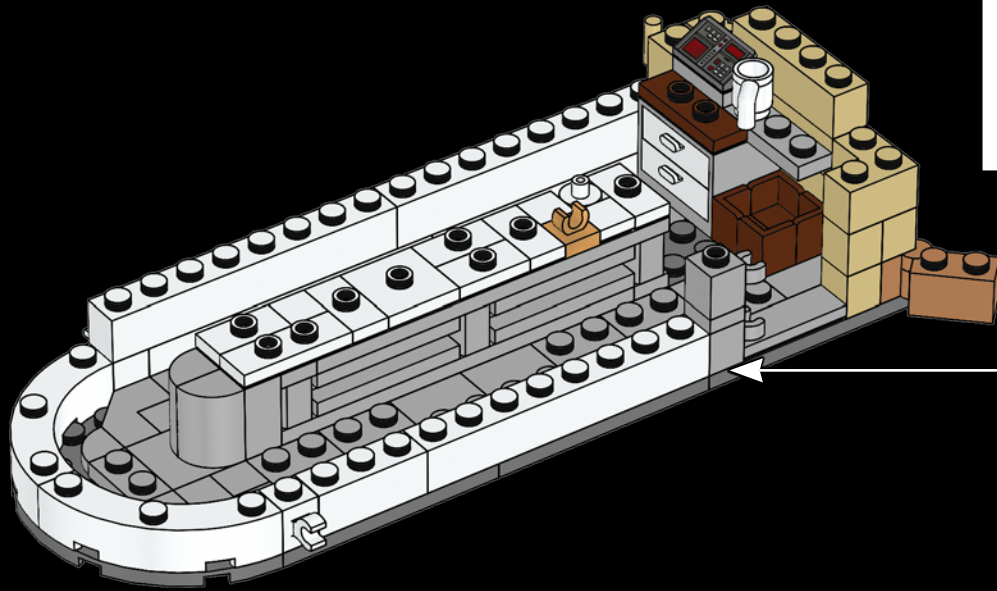

19

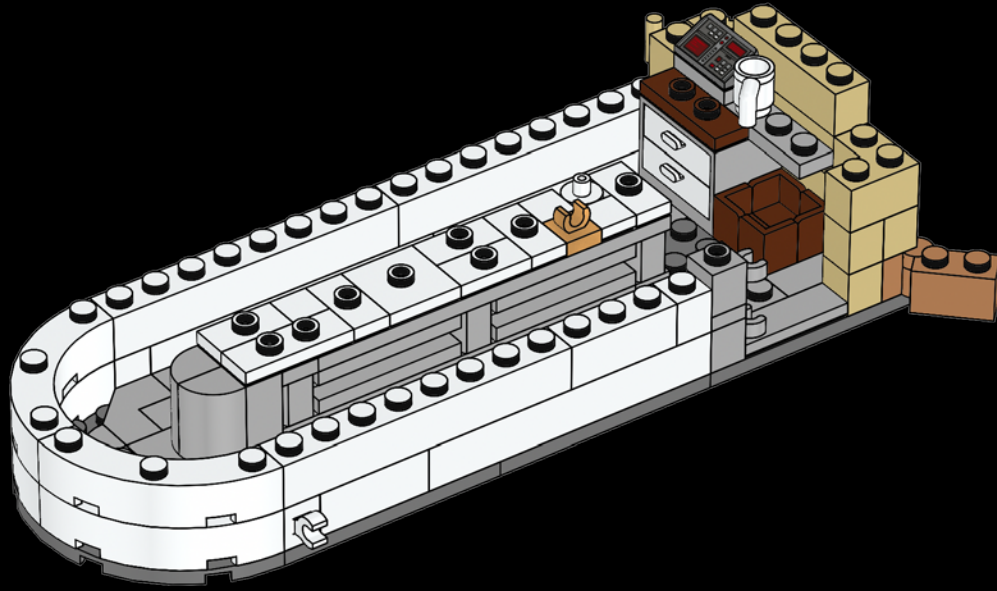

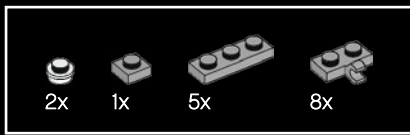

20

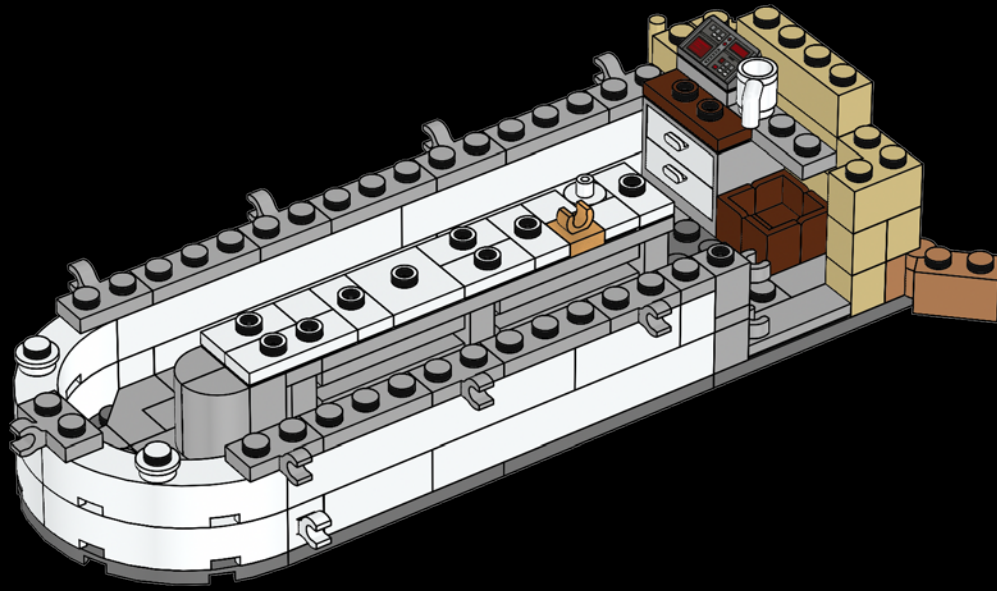

21

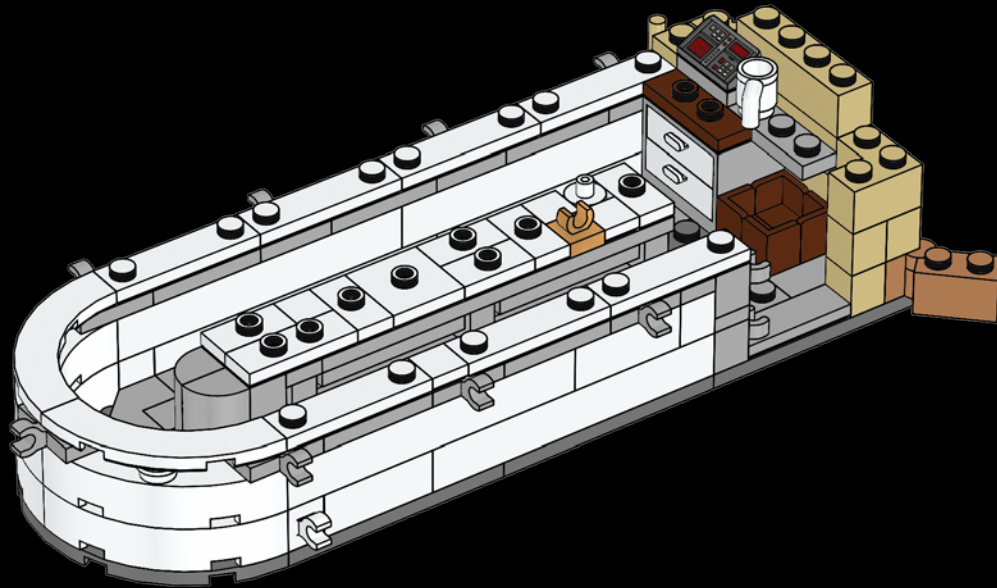

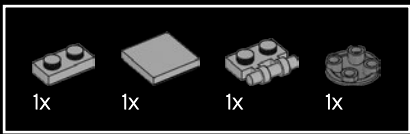

22

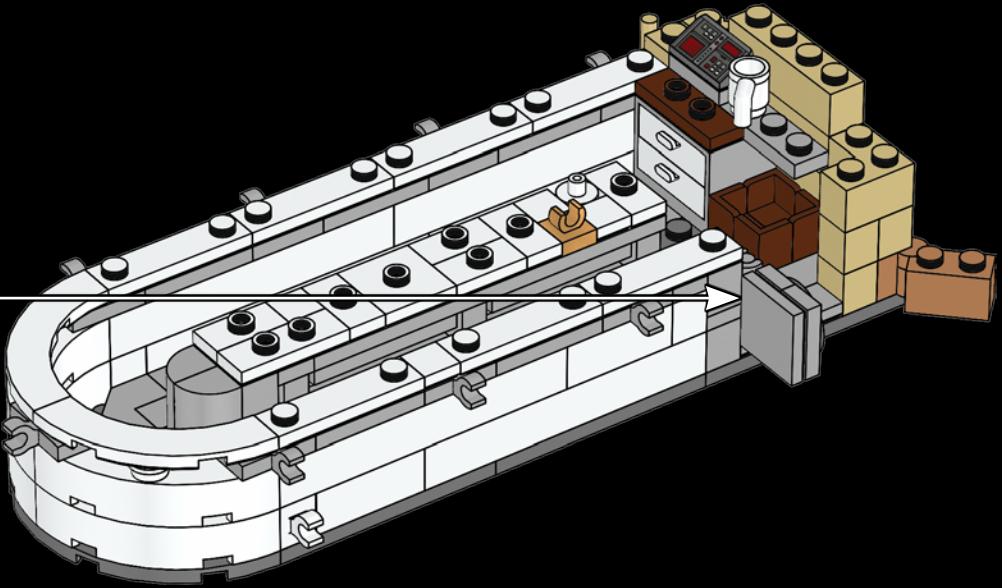
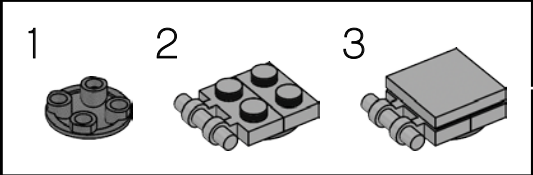

23

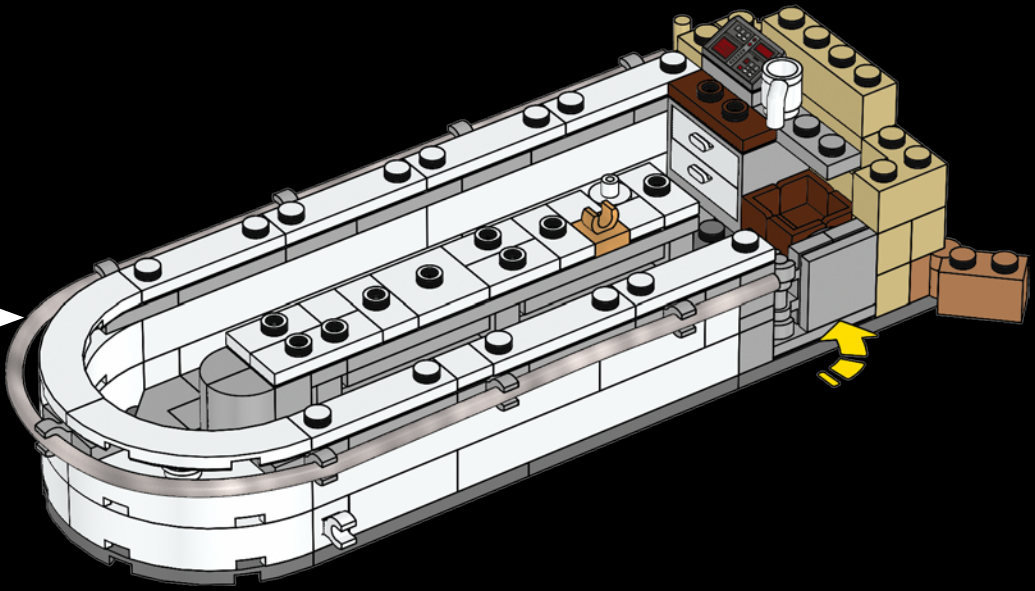



24

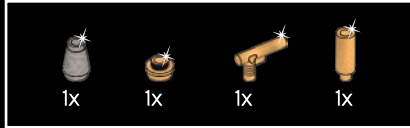
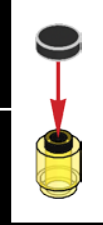
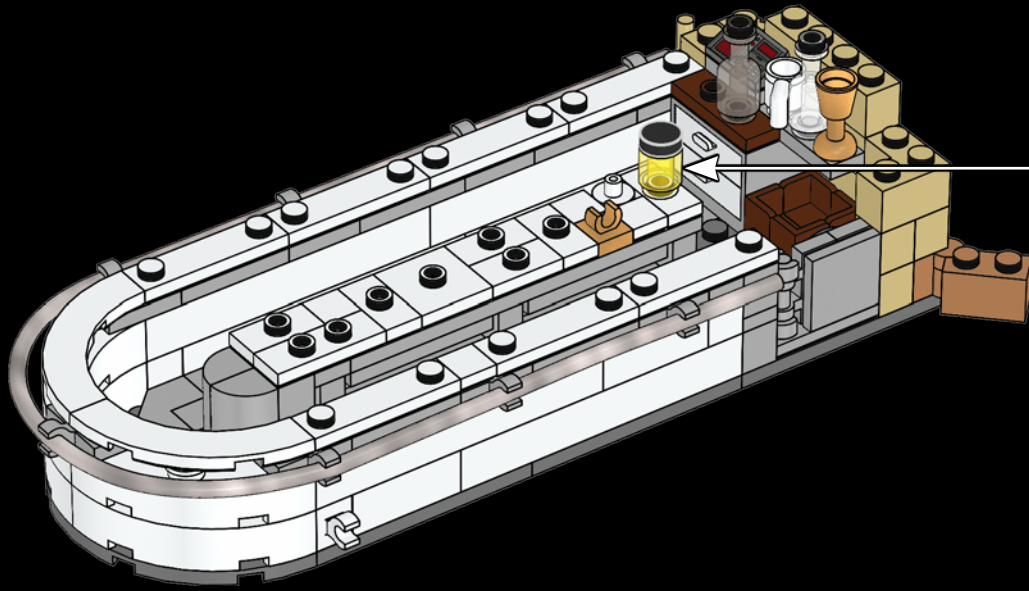

25

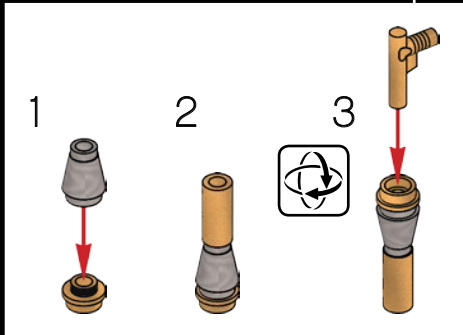
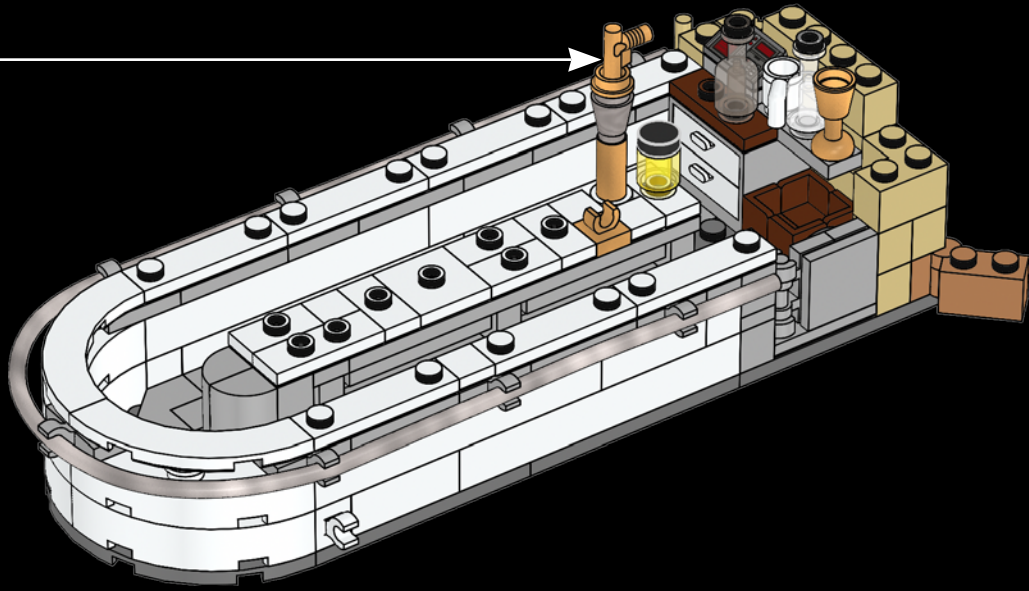



26

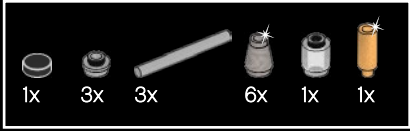
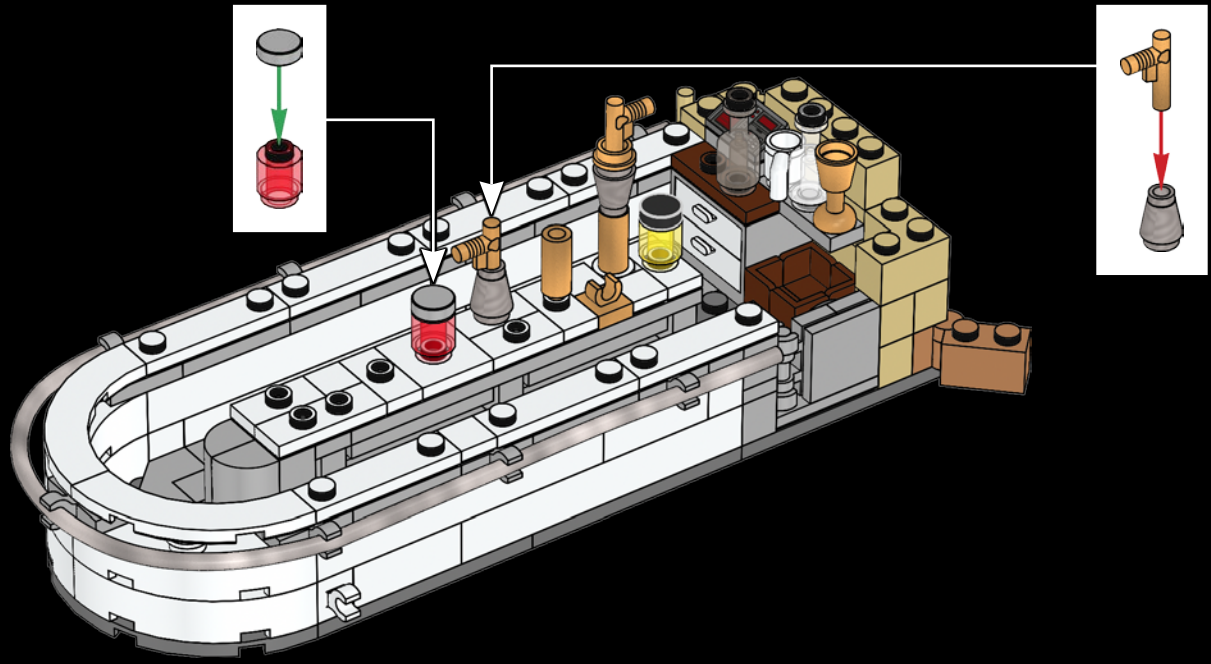

27

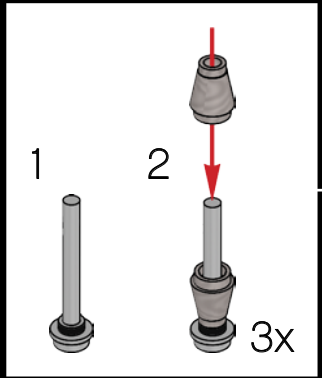
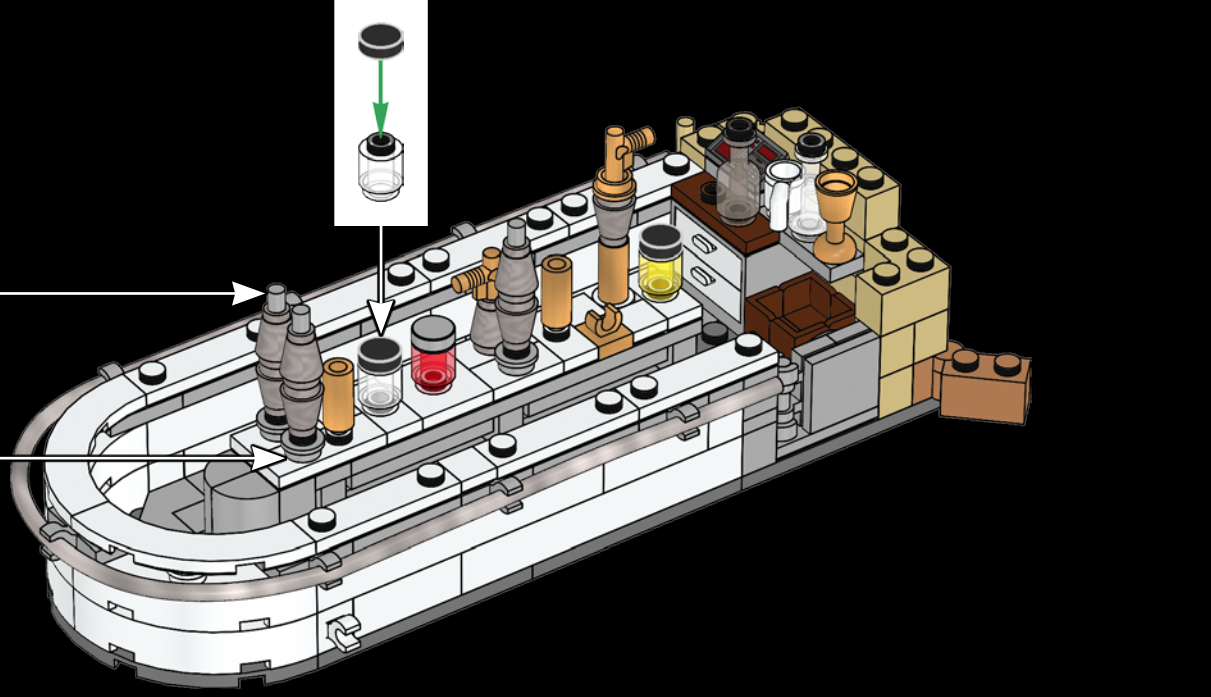

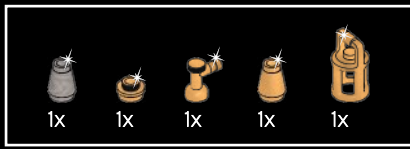

28

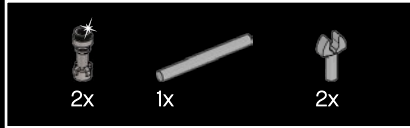
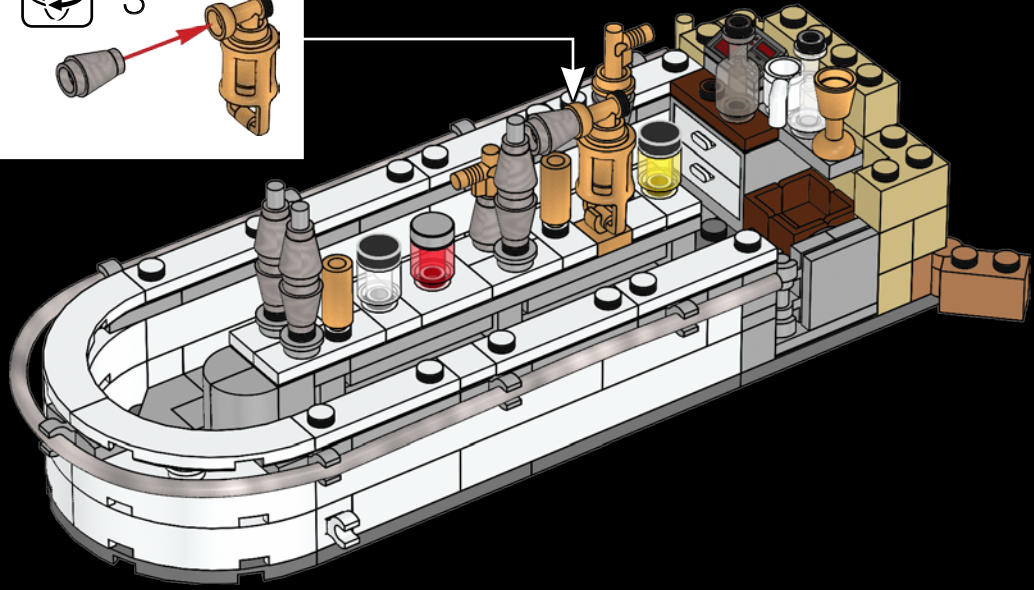
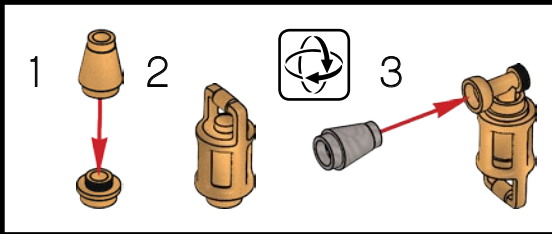

29

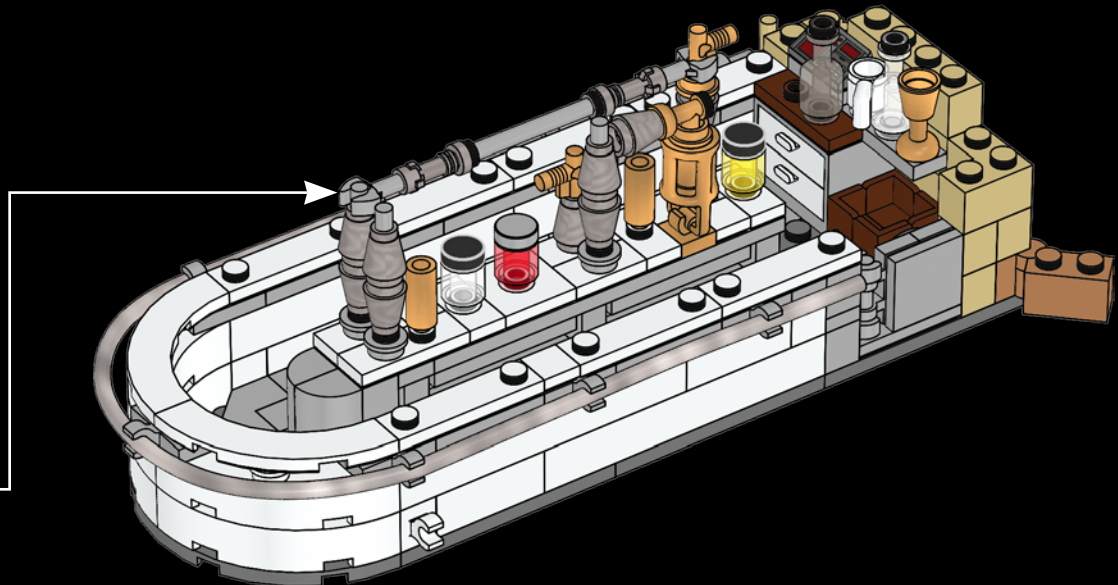
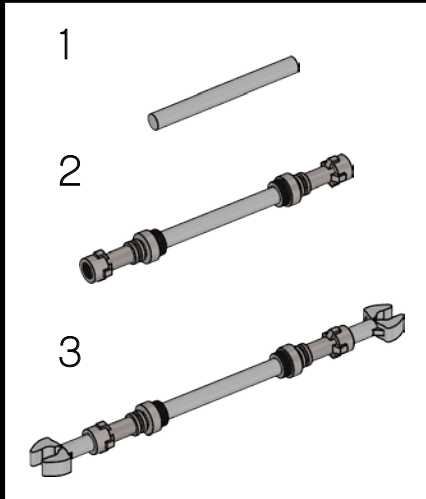



30

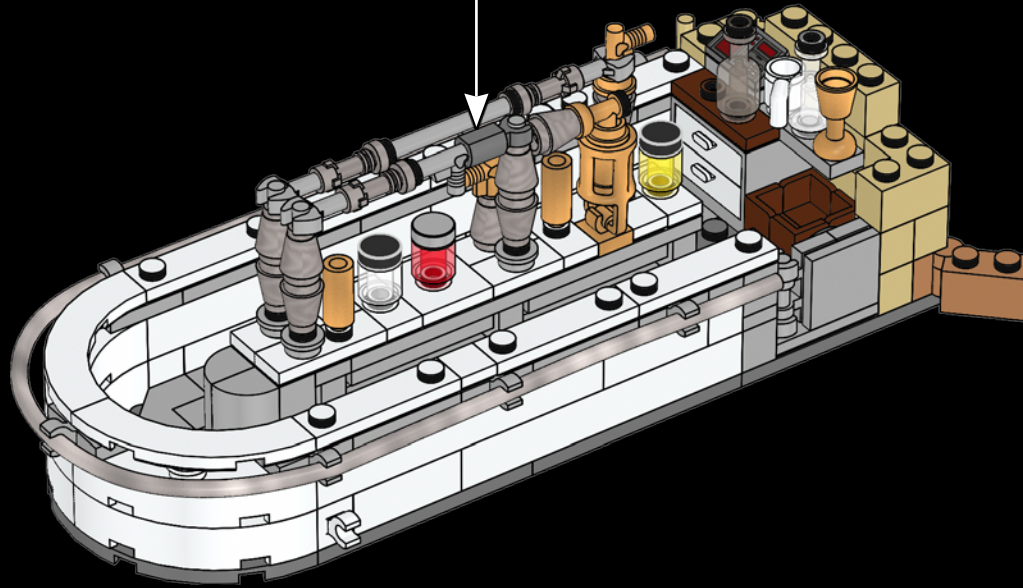
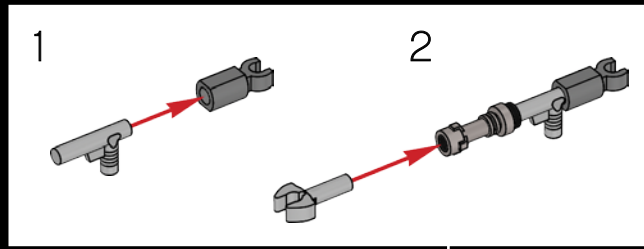

Some of the Cantina's Bar shiny metallic parts were reused from droid parts - the IG-88 heads.

Certaines des pièces métalliques brillantes du bar de la cantina ont été créées à partir de pièces de droïdes - des têtes d'IG-88.

Algunas de las brillantes piezas metálicas de la barra de la cantina son en realidad partes reutilizadas: cabezas de droïdes IG-88.

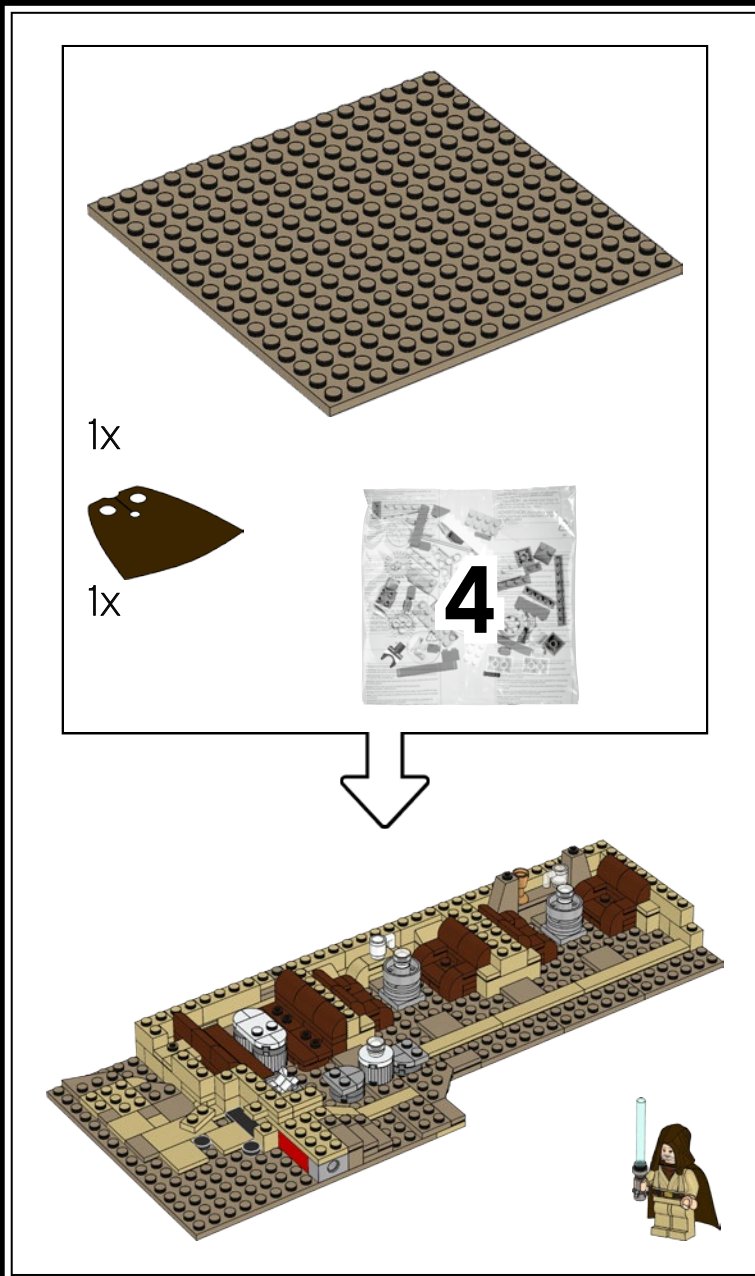

“Mos Eisley Spaceport. You will never find a more wretched hive of scum and villainy.”

- Obi-Wan Kenobi

« L'astroport de Mos Eisley. Cette ville est le repaire des malandrins les plus infâmes de toute la galaxie. »

- Obi-Wan Kenobi

“El puerto espacial de Mos Eisley. No encontrarás nunca otro lugar como este, tan lleno de maldad y vileza”.

- Obi-Wan Kenobi

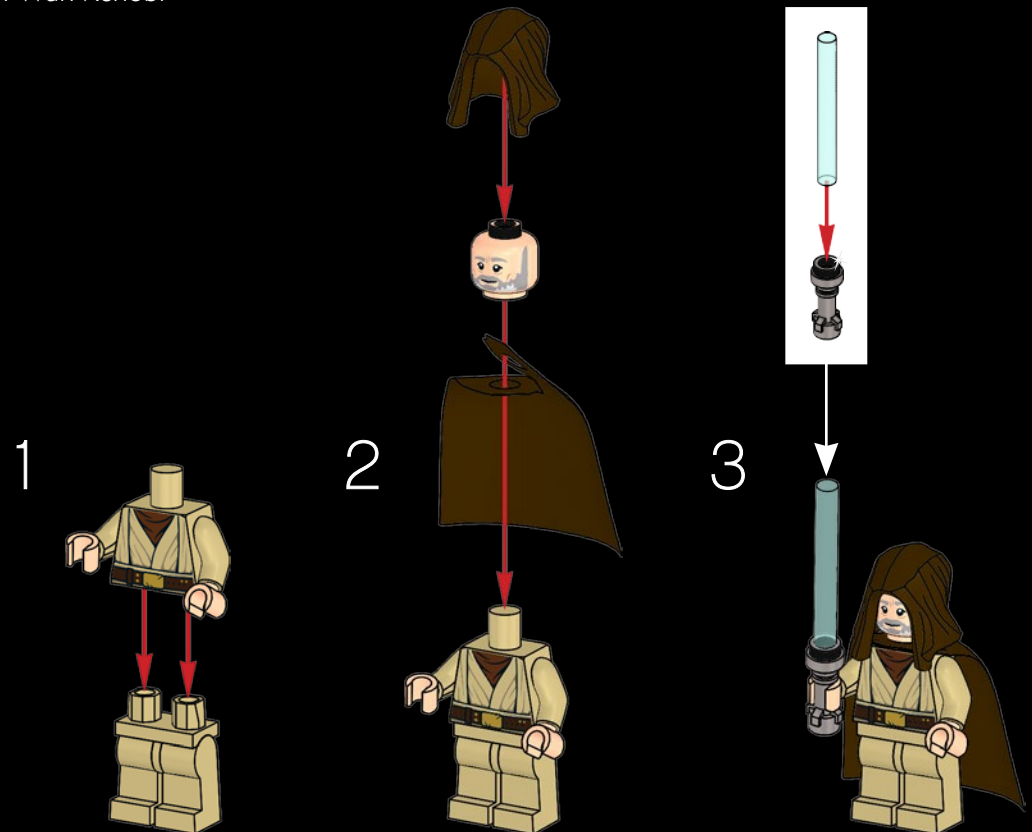

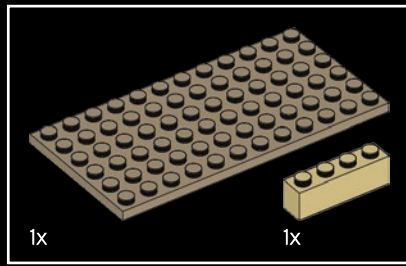
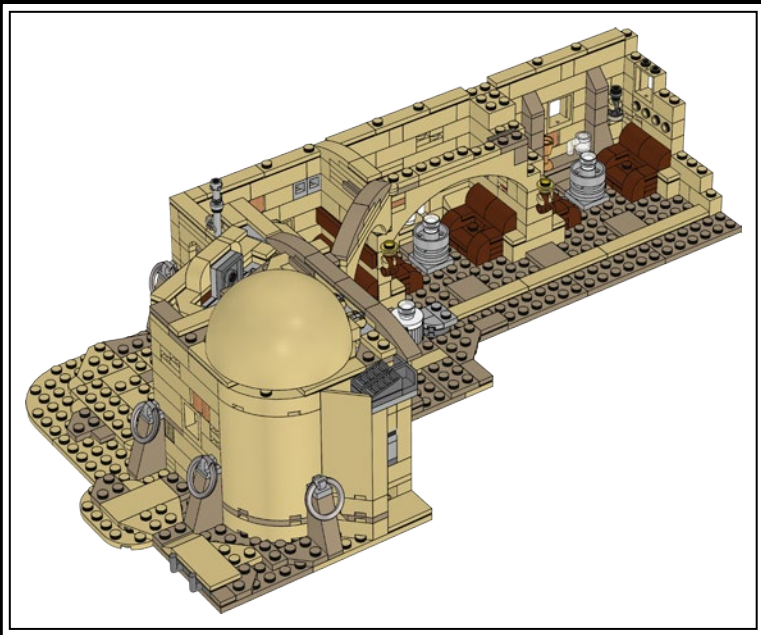

31

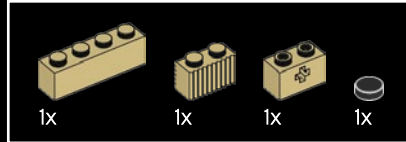
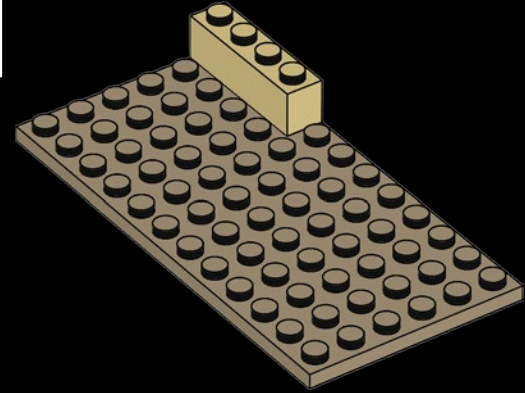

32

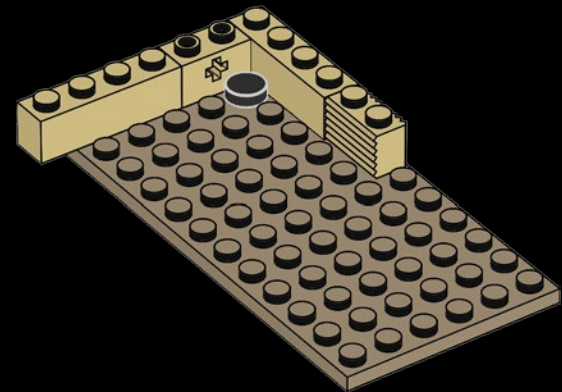

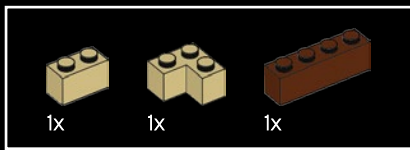

33

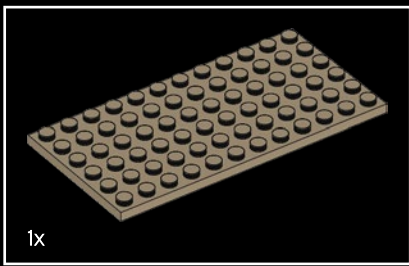
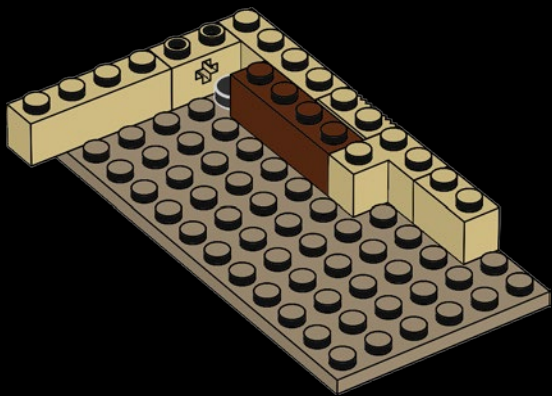

35



34

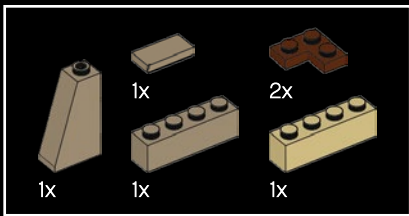
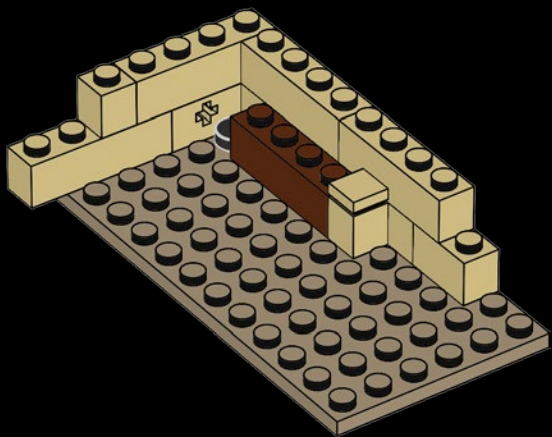

36



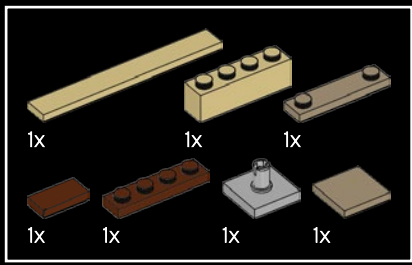

37

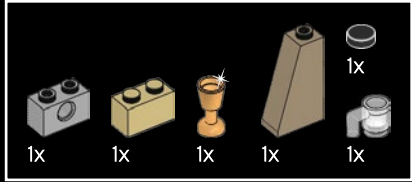

38



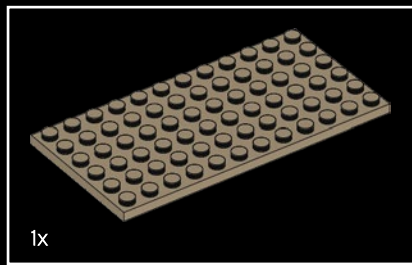

1x

39

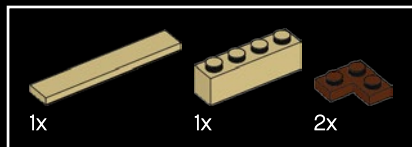

1x

1x

2x

40



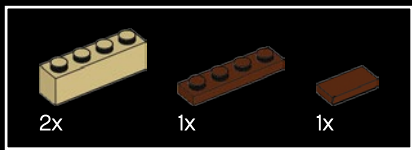

41

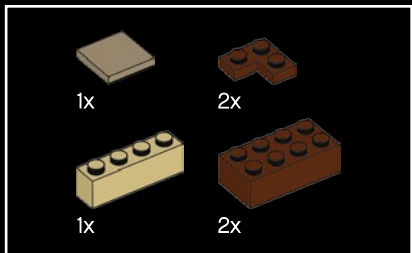

42



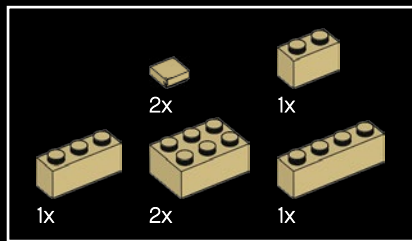

43



44



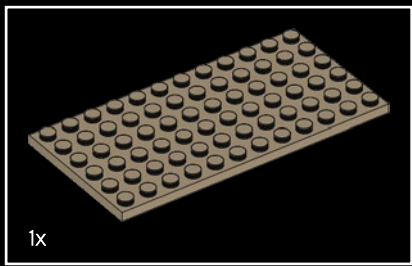

1x

45

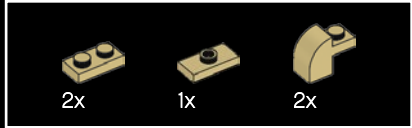

2x

1x

2x

46

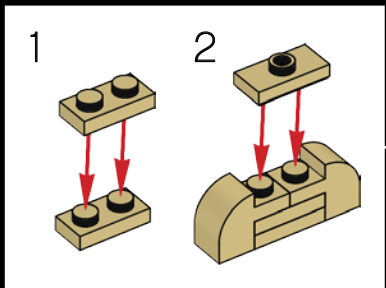

1

2



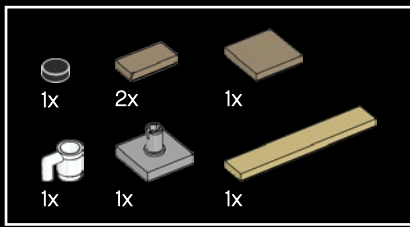

47

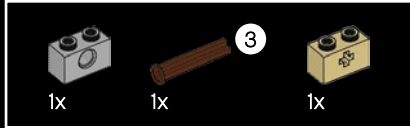
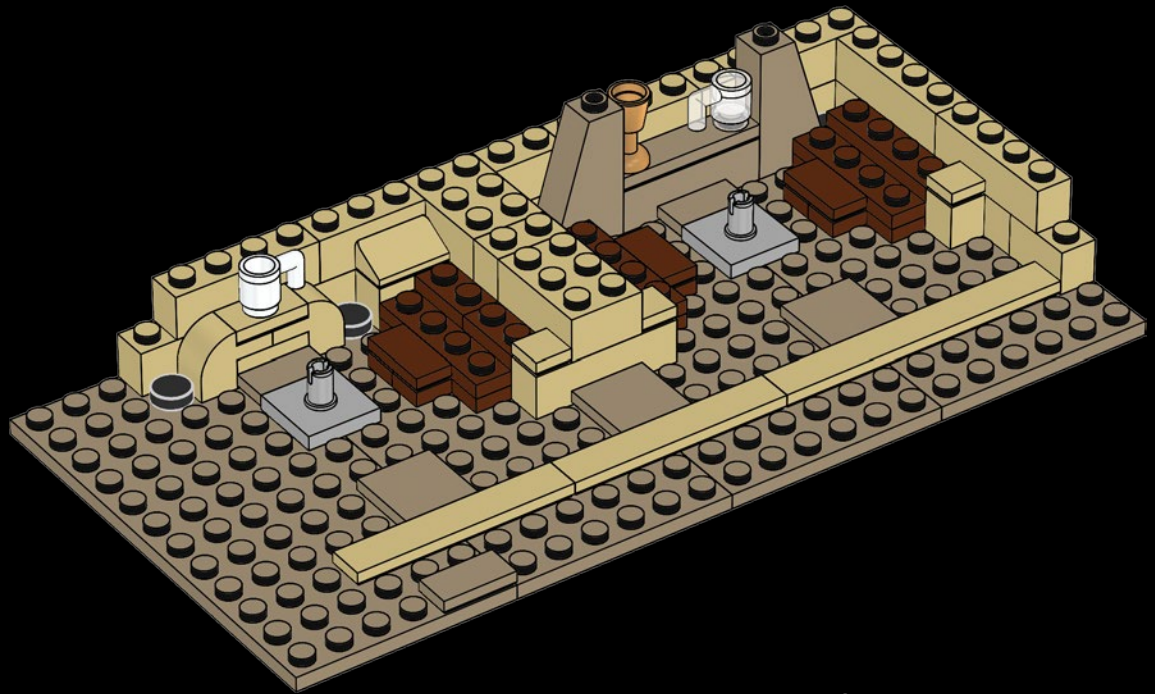

48

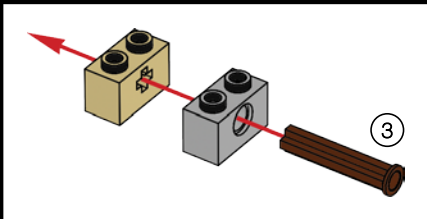



49

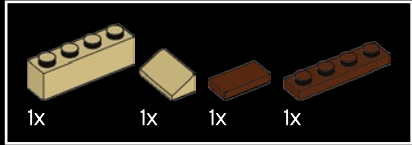

50



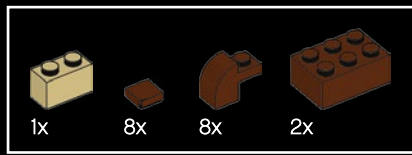

51

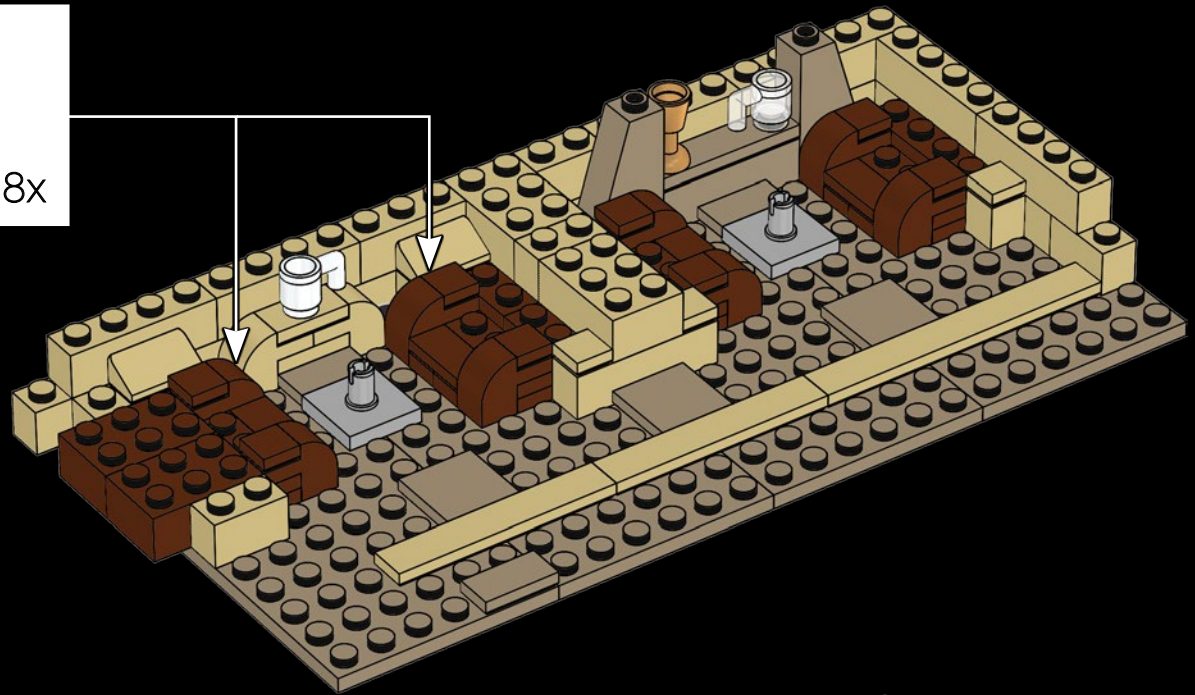
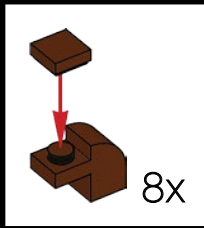

52

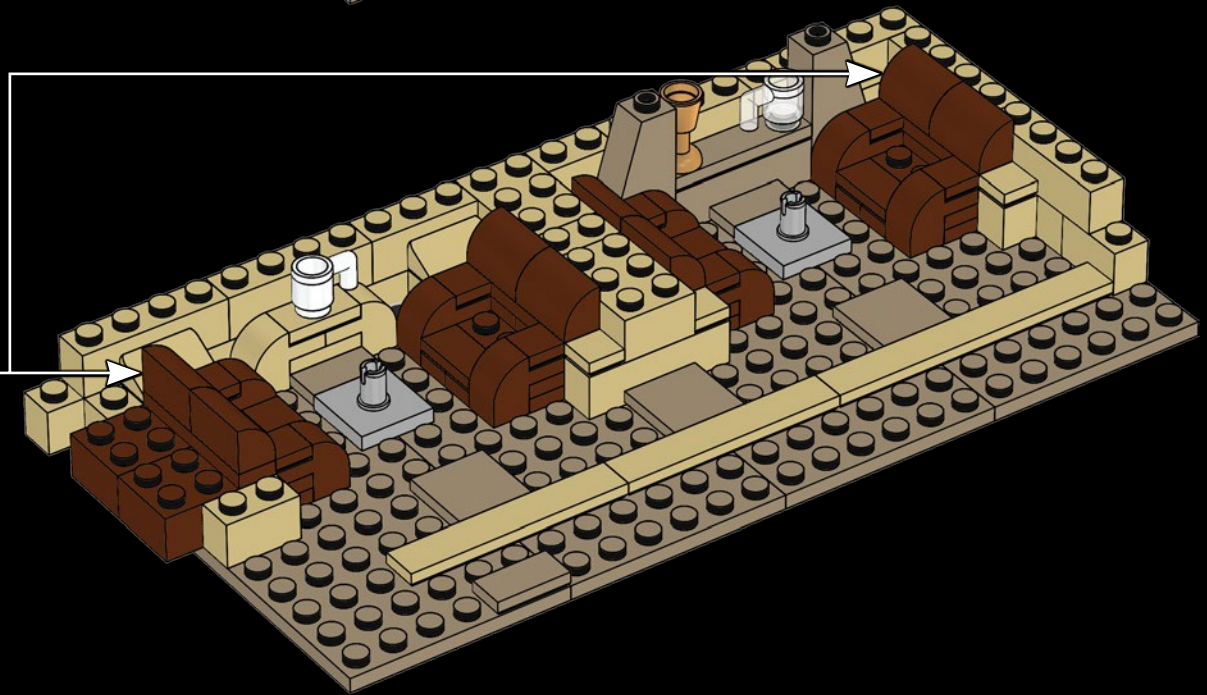
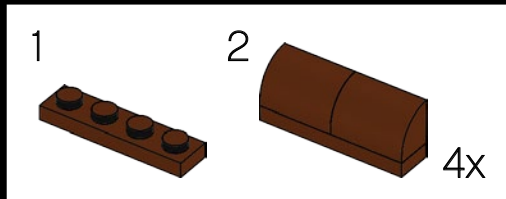

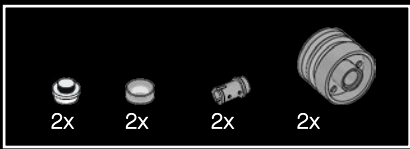

53

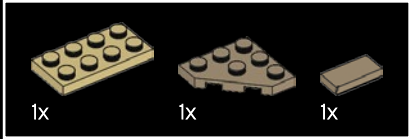
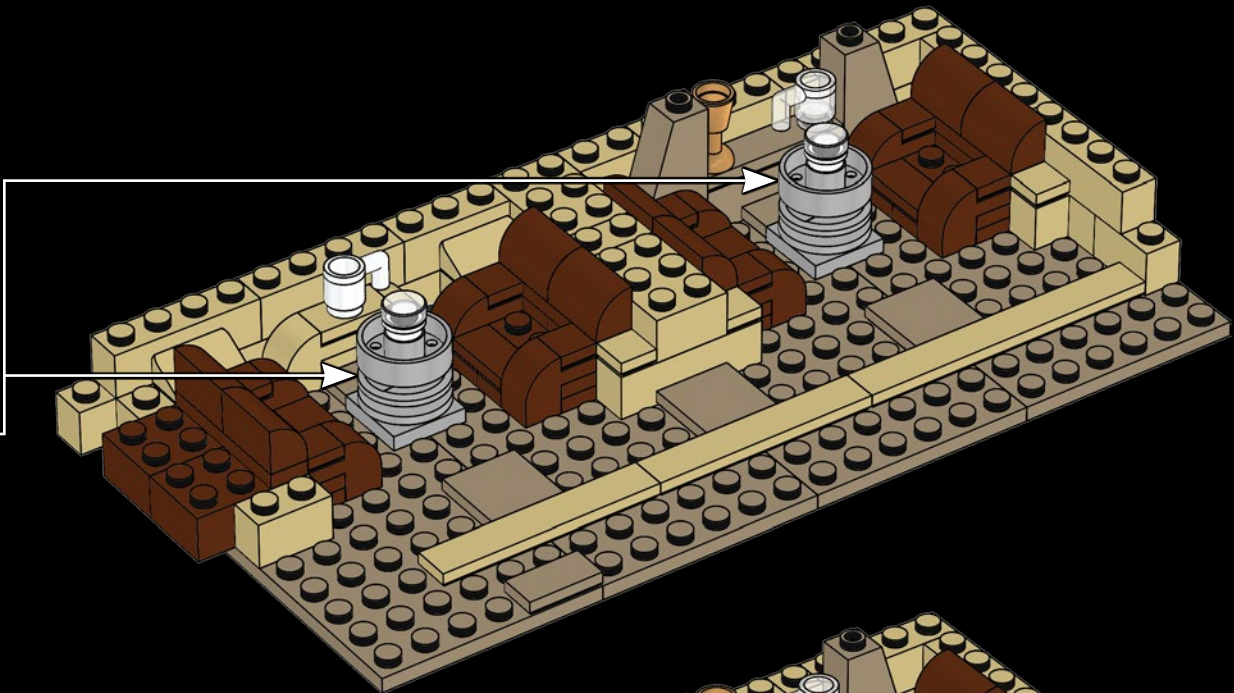
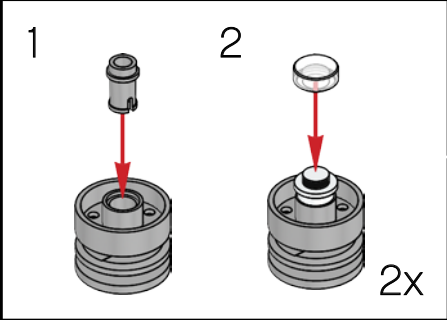

54

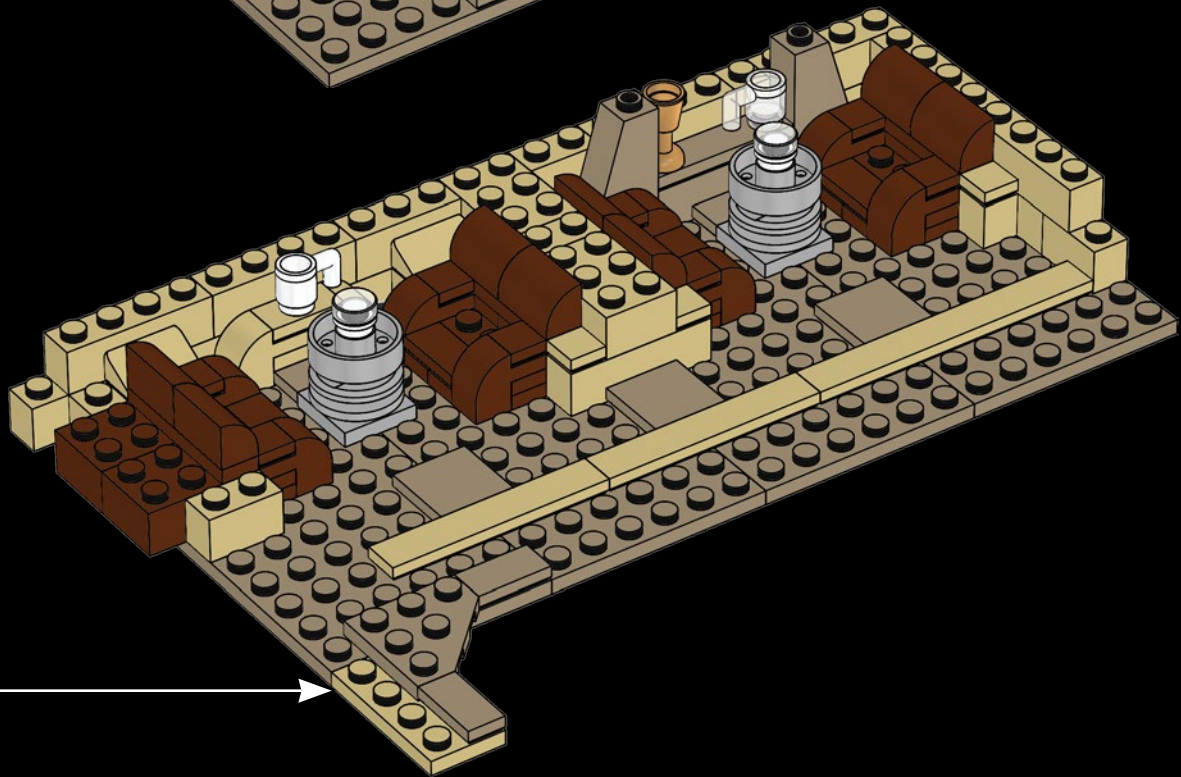
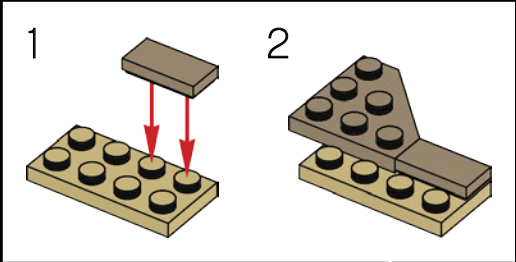

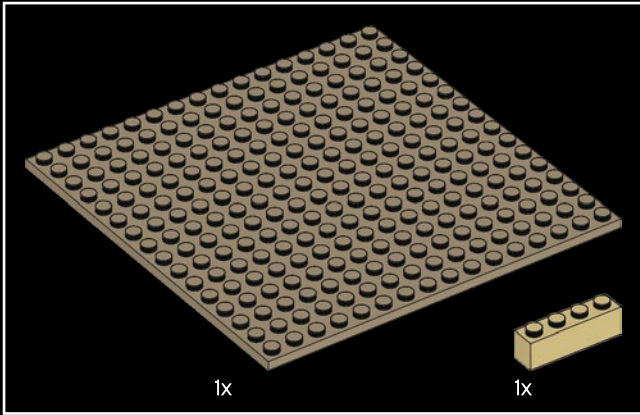
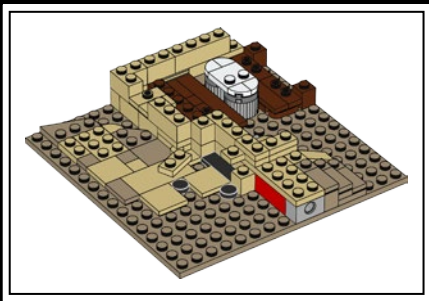

55

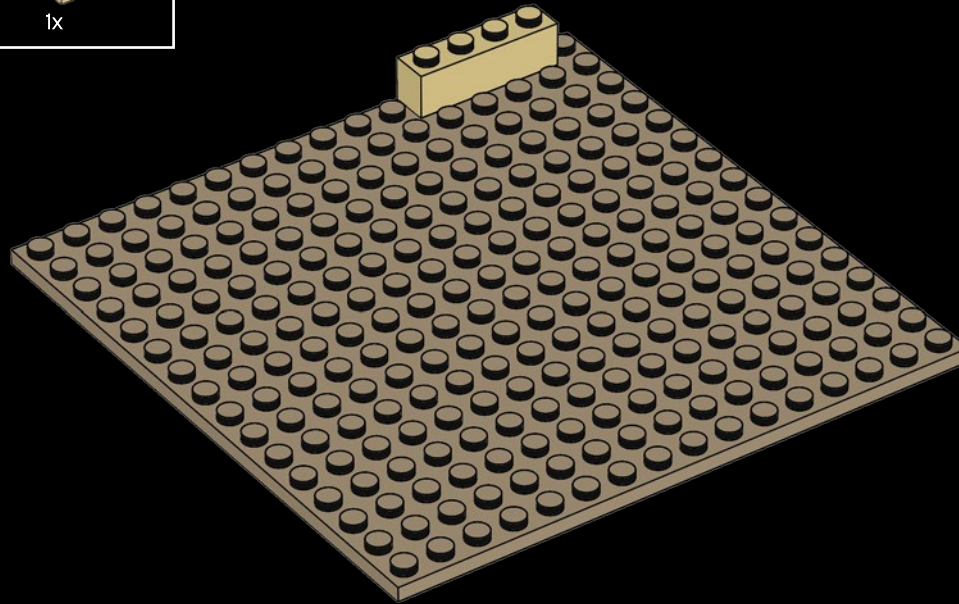



56

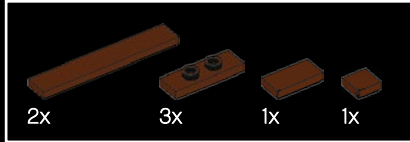

57



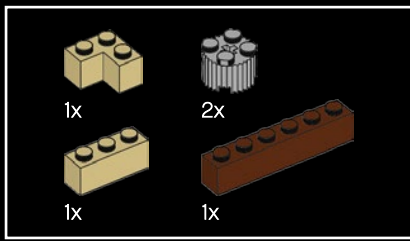

58

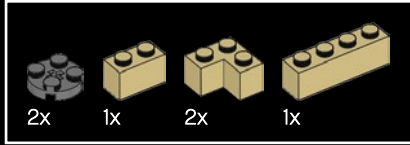
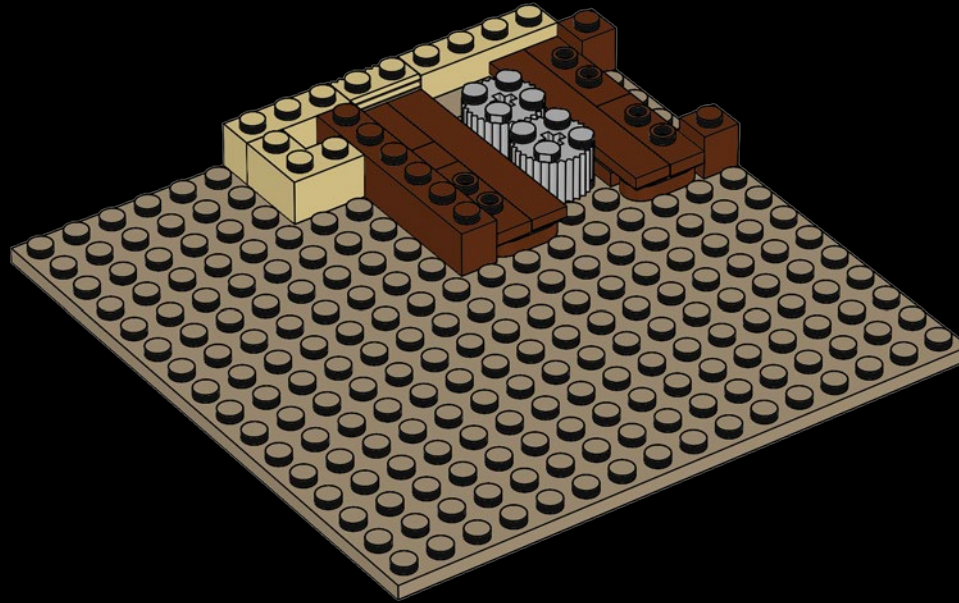

59

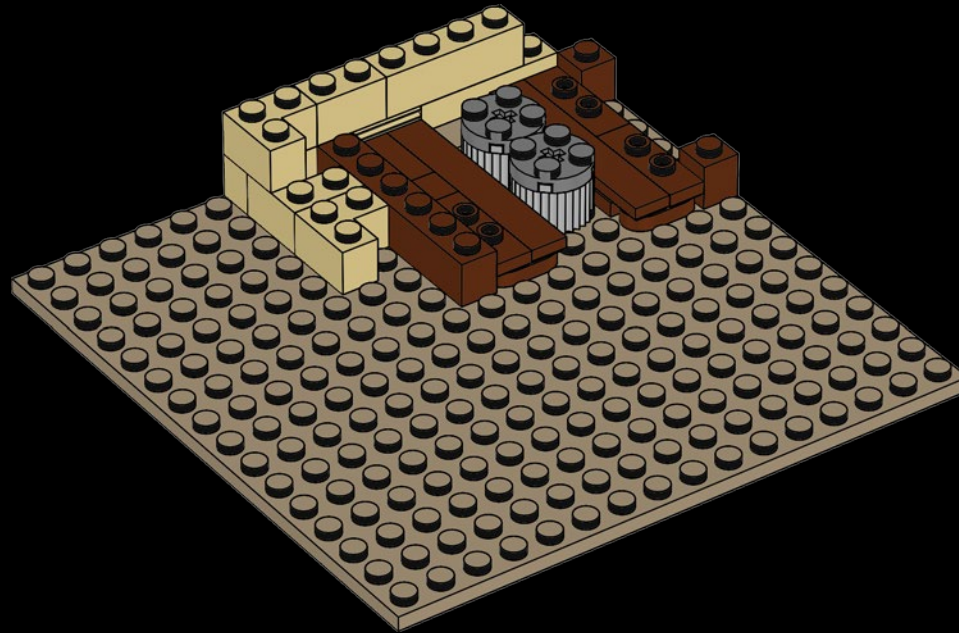

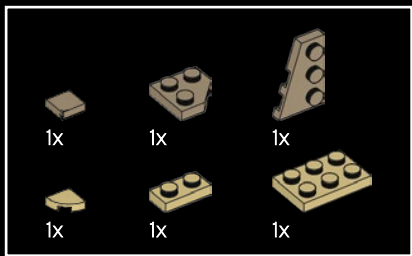

60

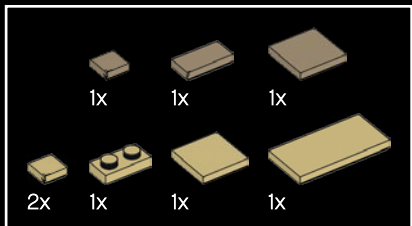

61

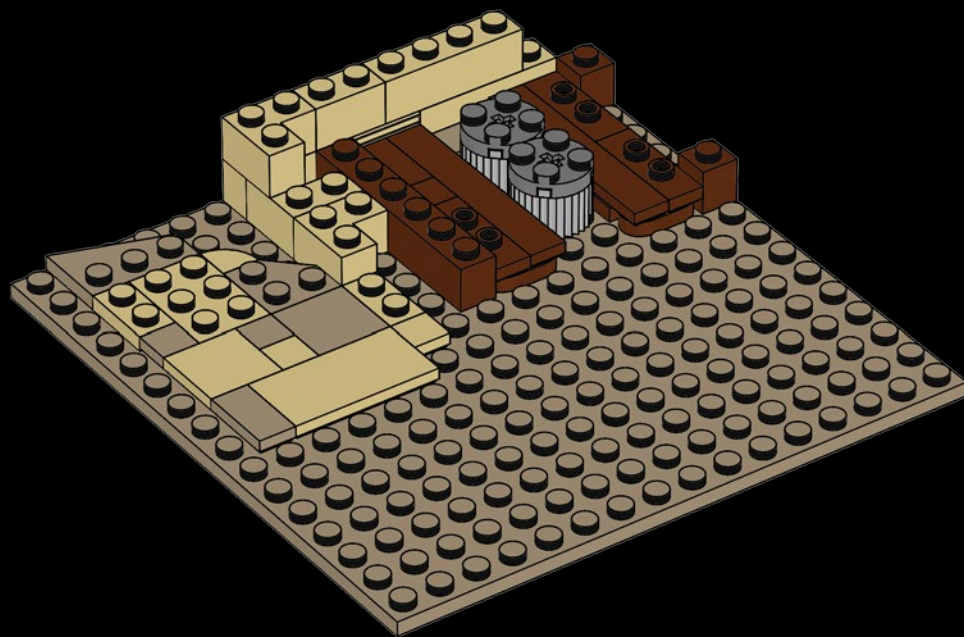

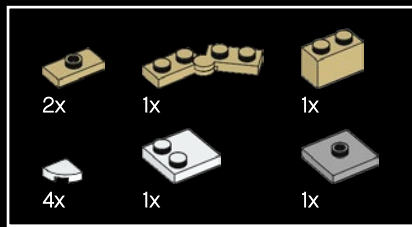

62

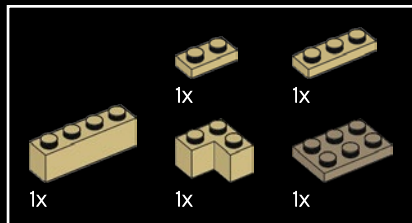
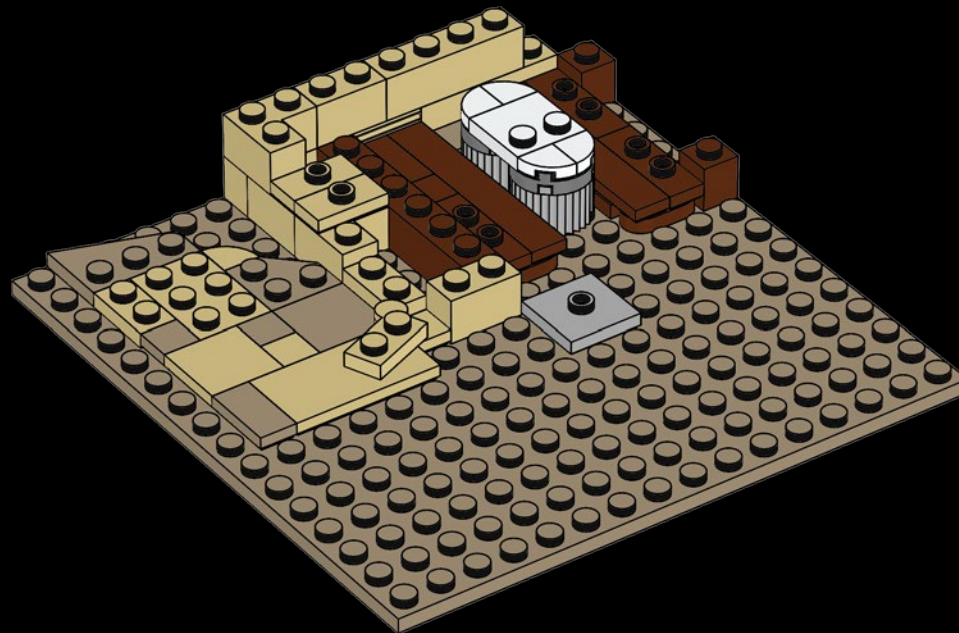

63

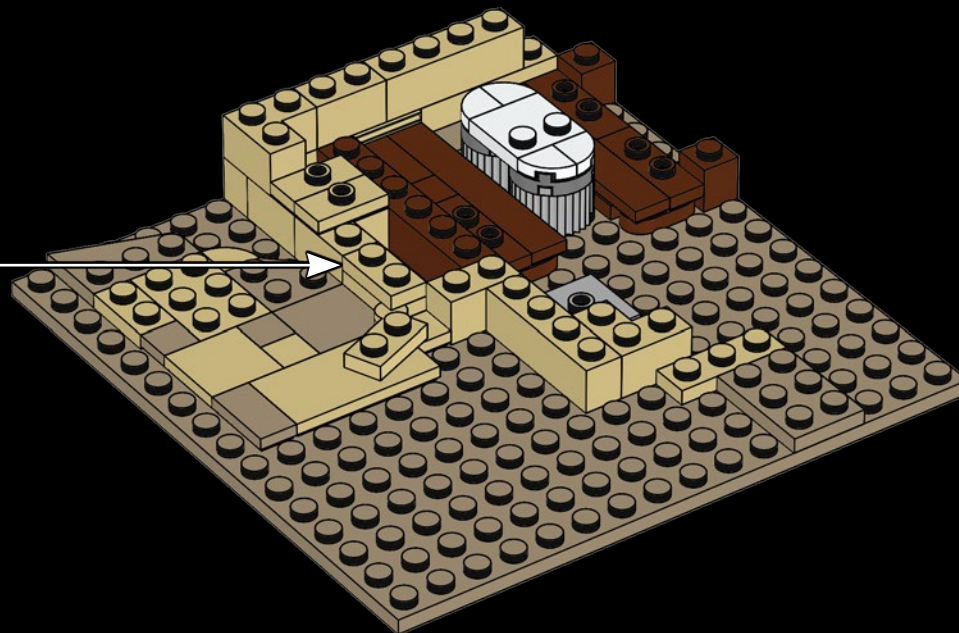

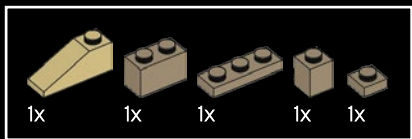

64

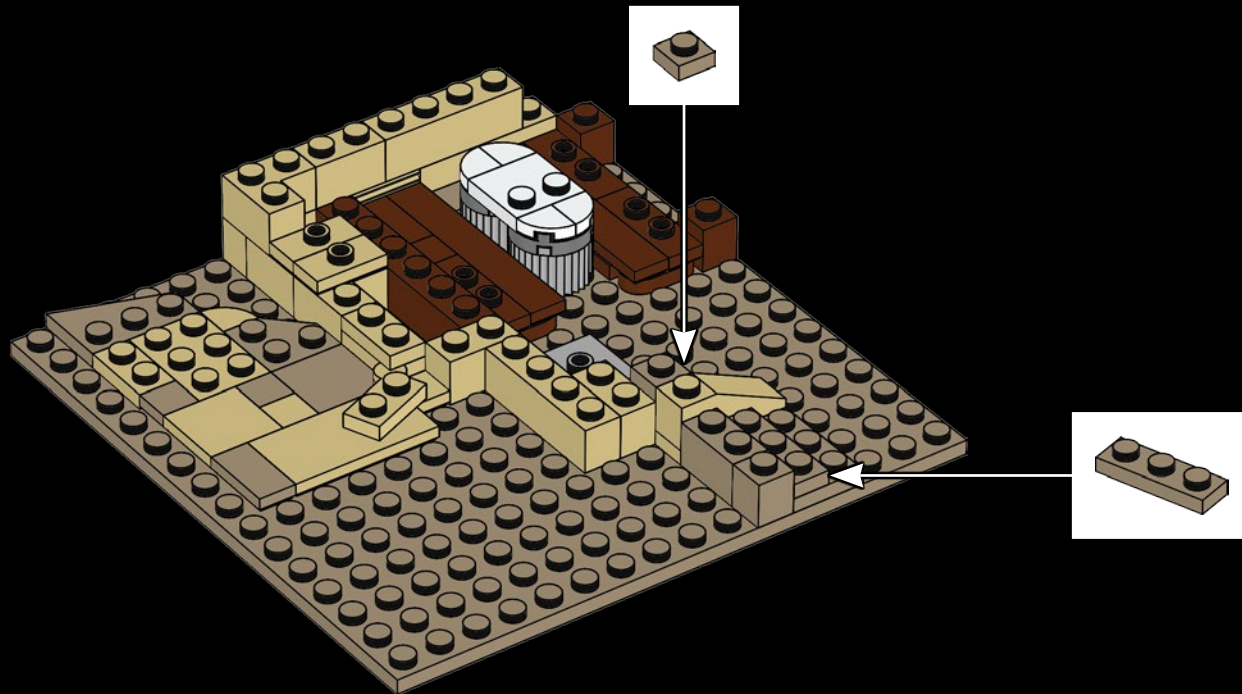

65



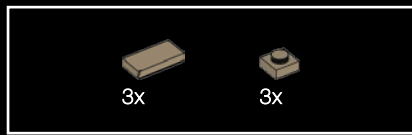

66

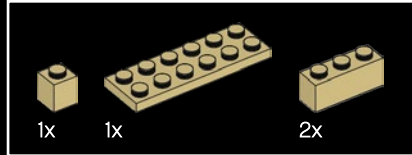
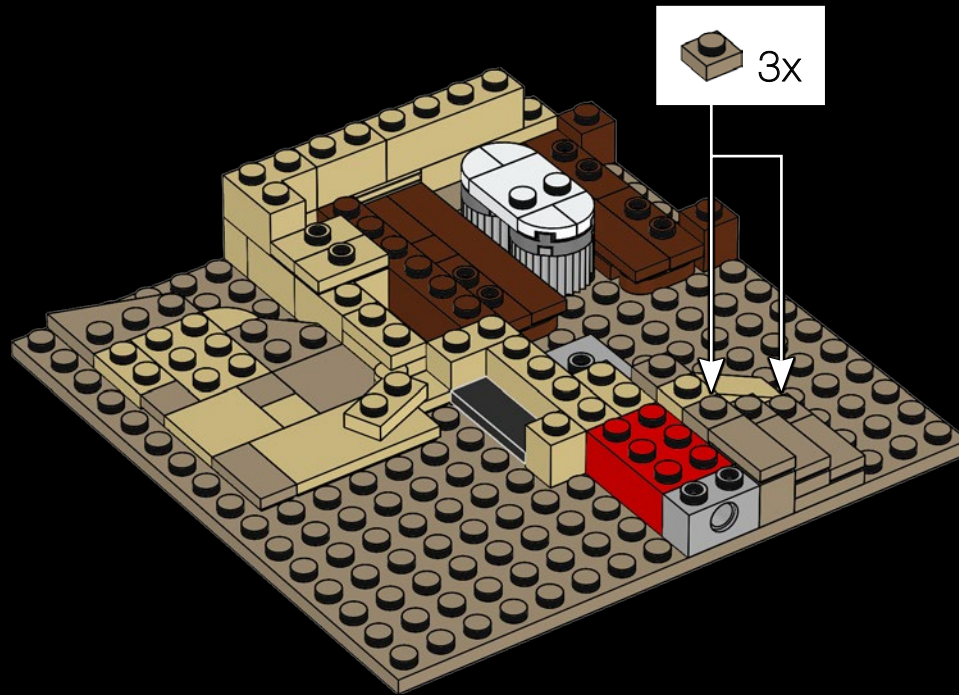

67





68



69



70

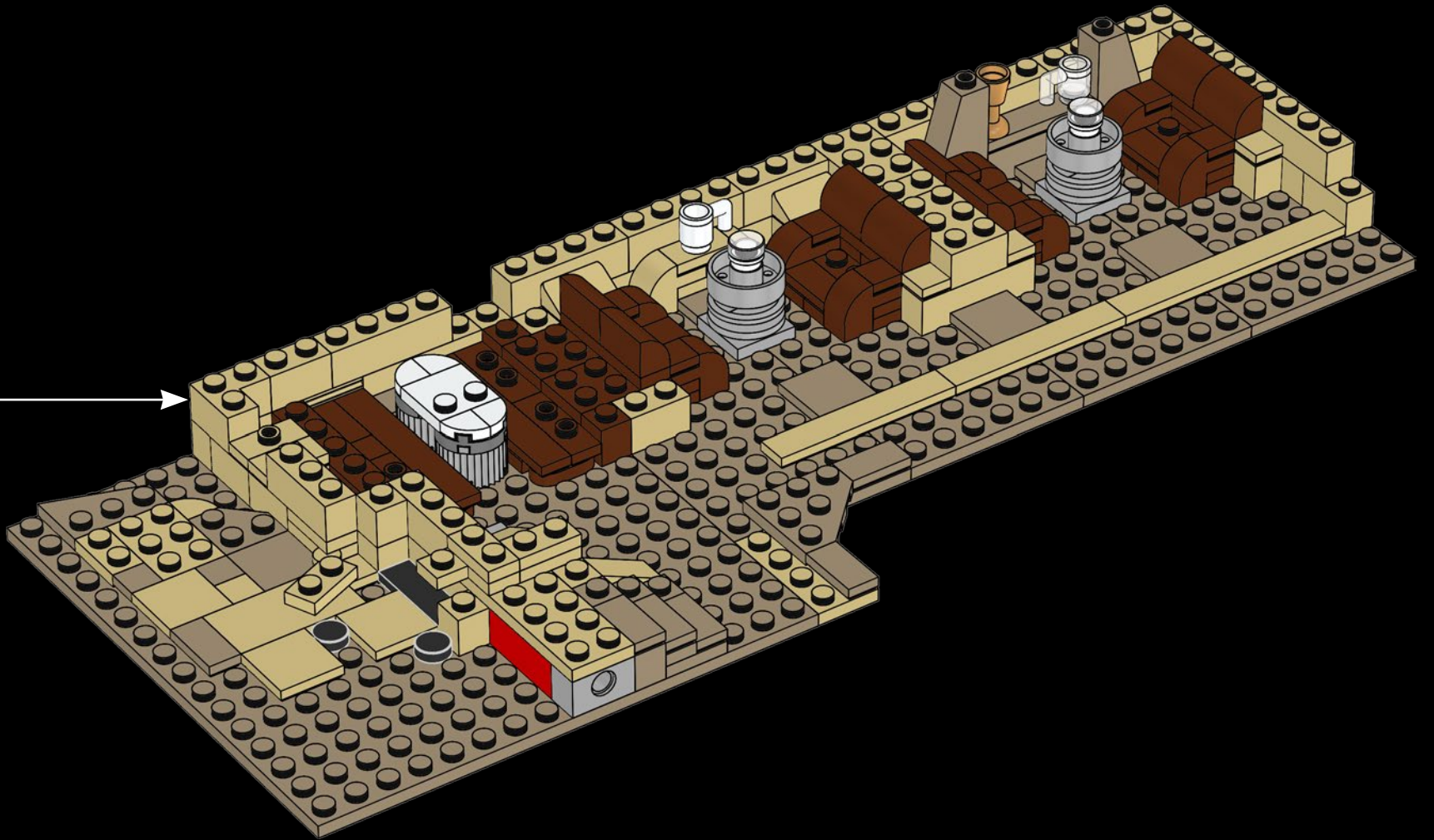

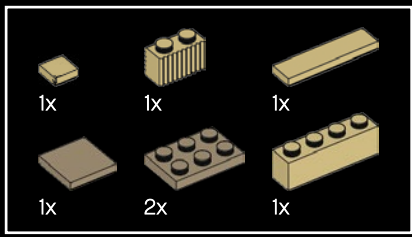

71

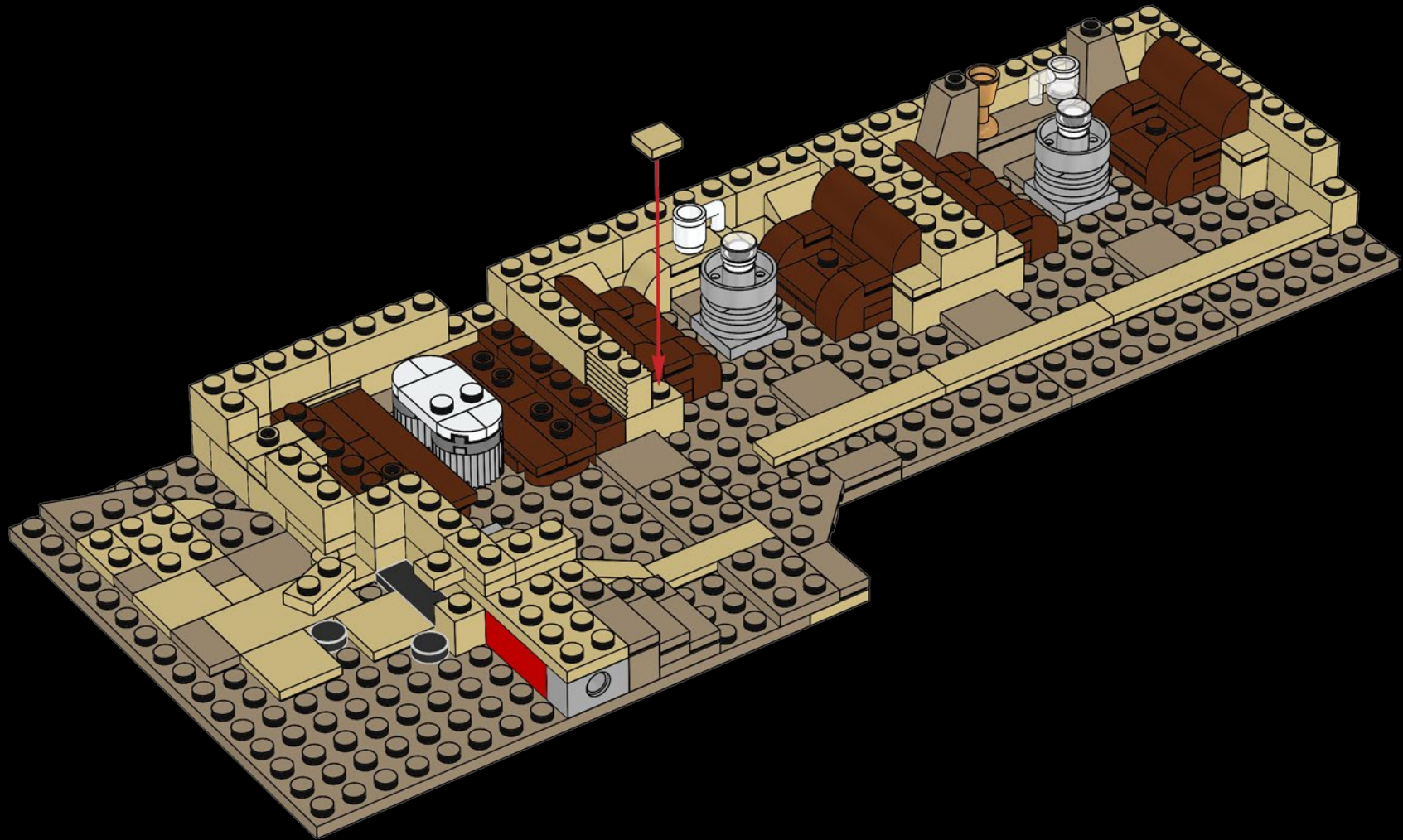



72

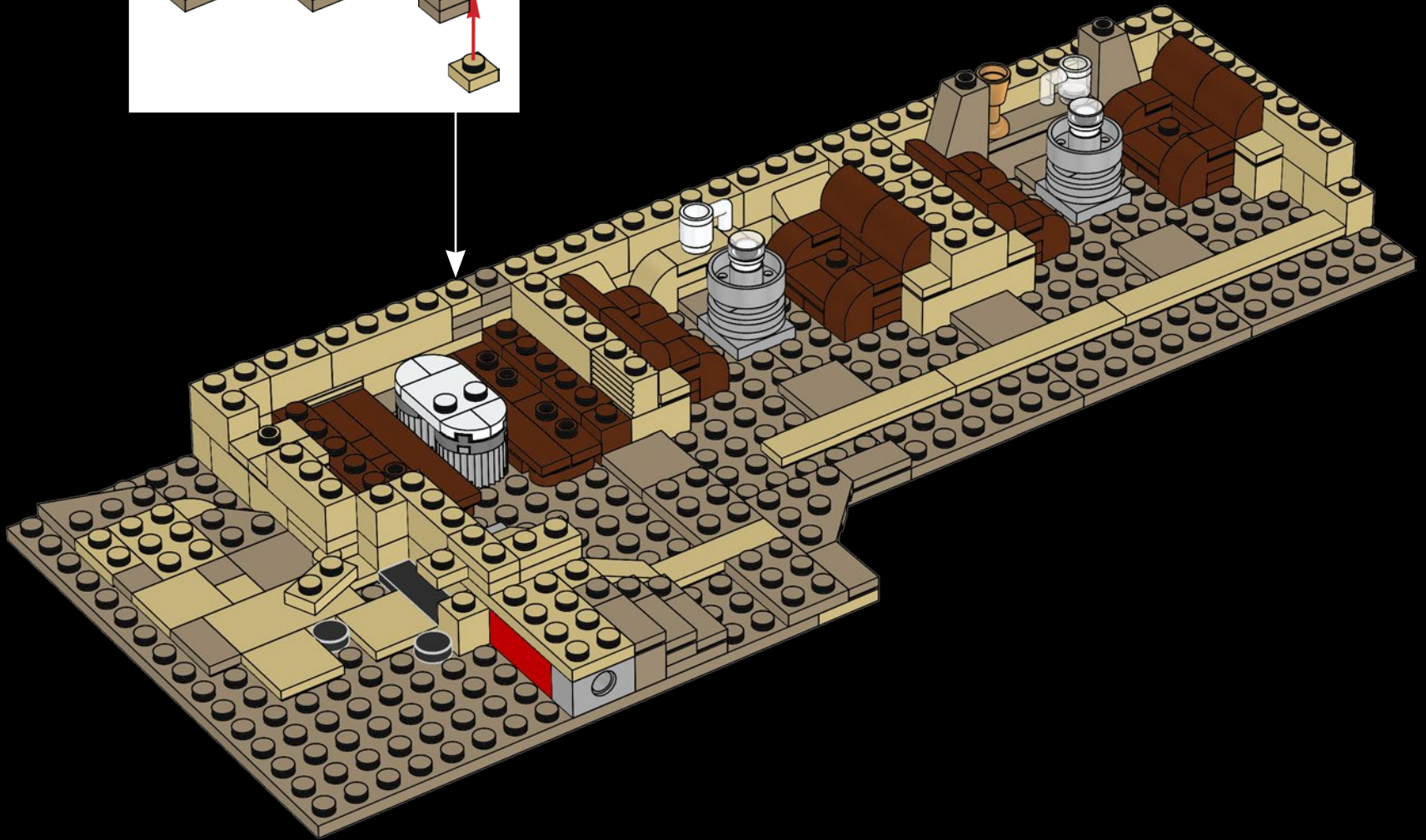
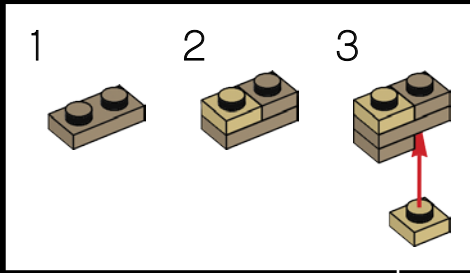

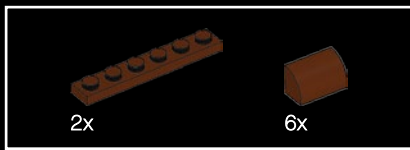

73

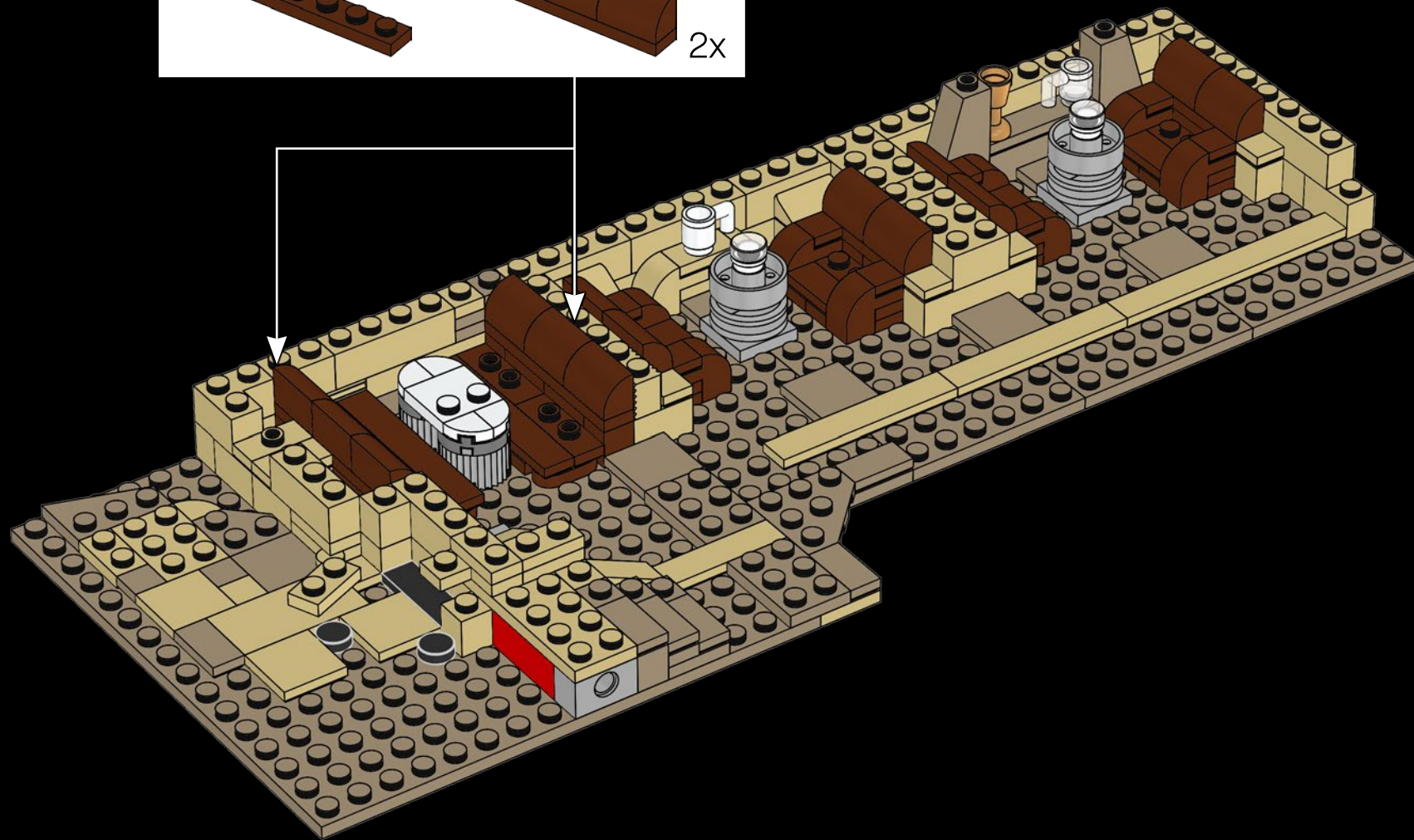
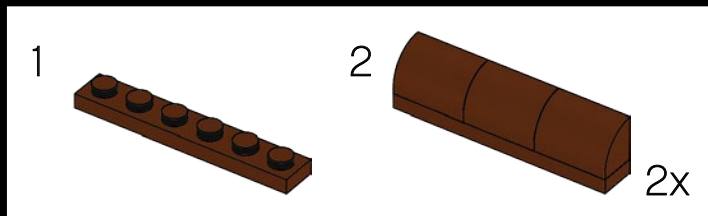

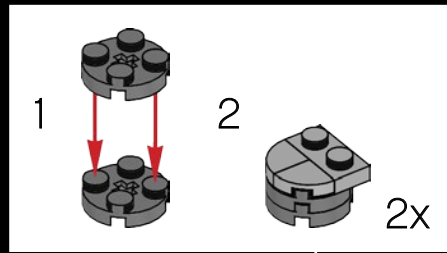
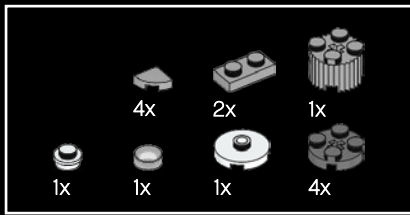

74

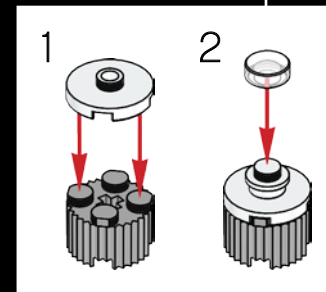
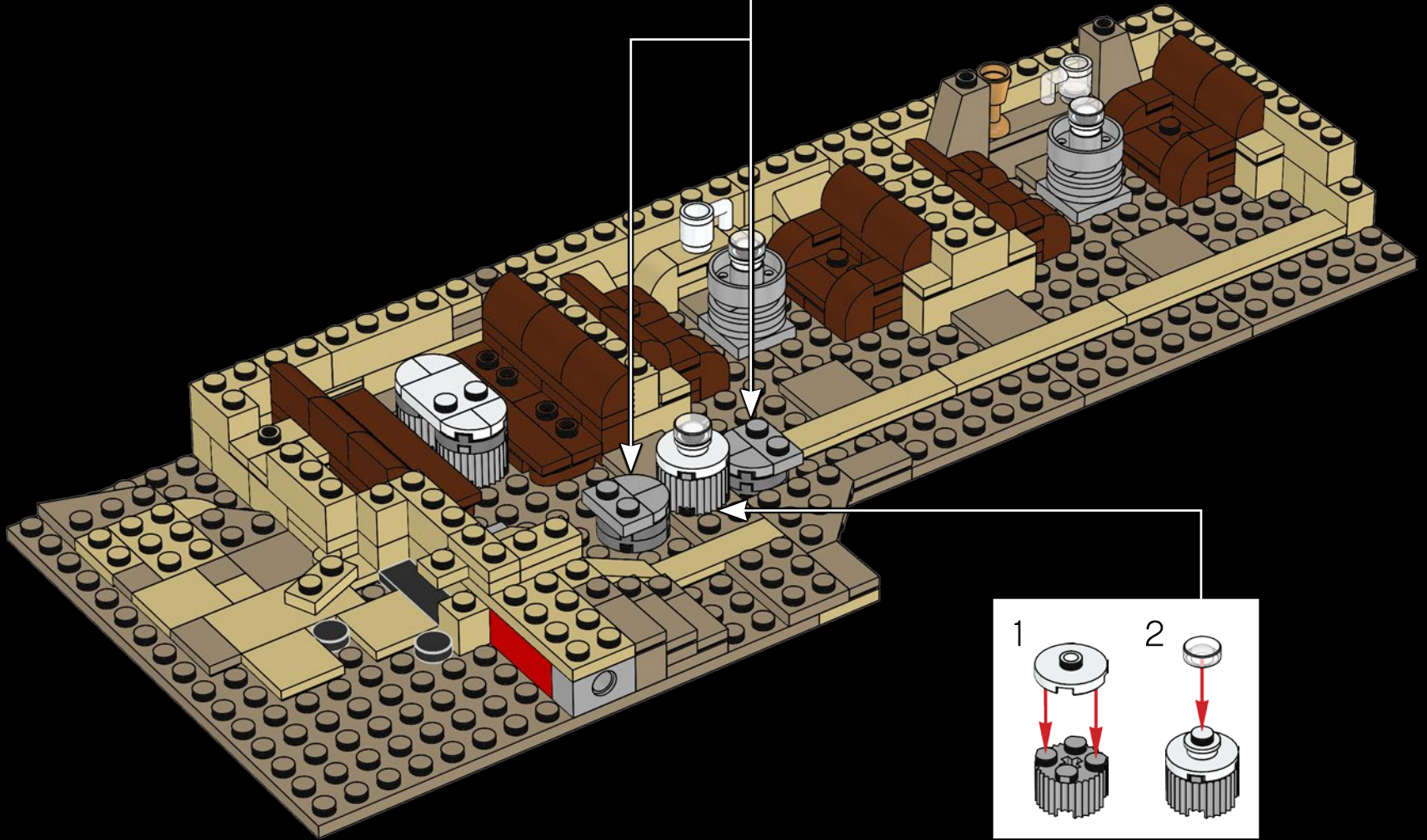



75

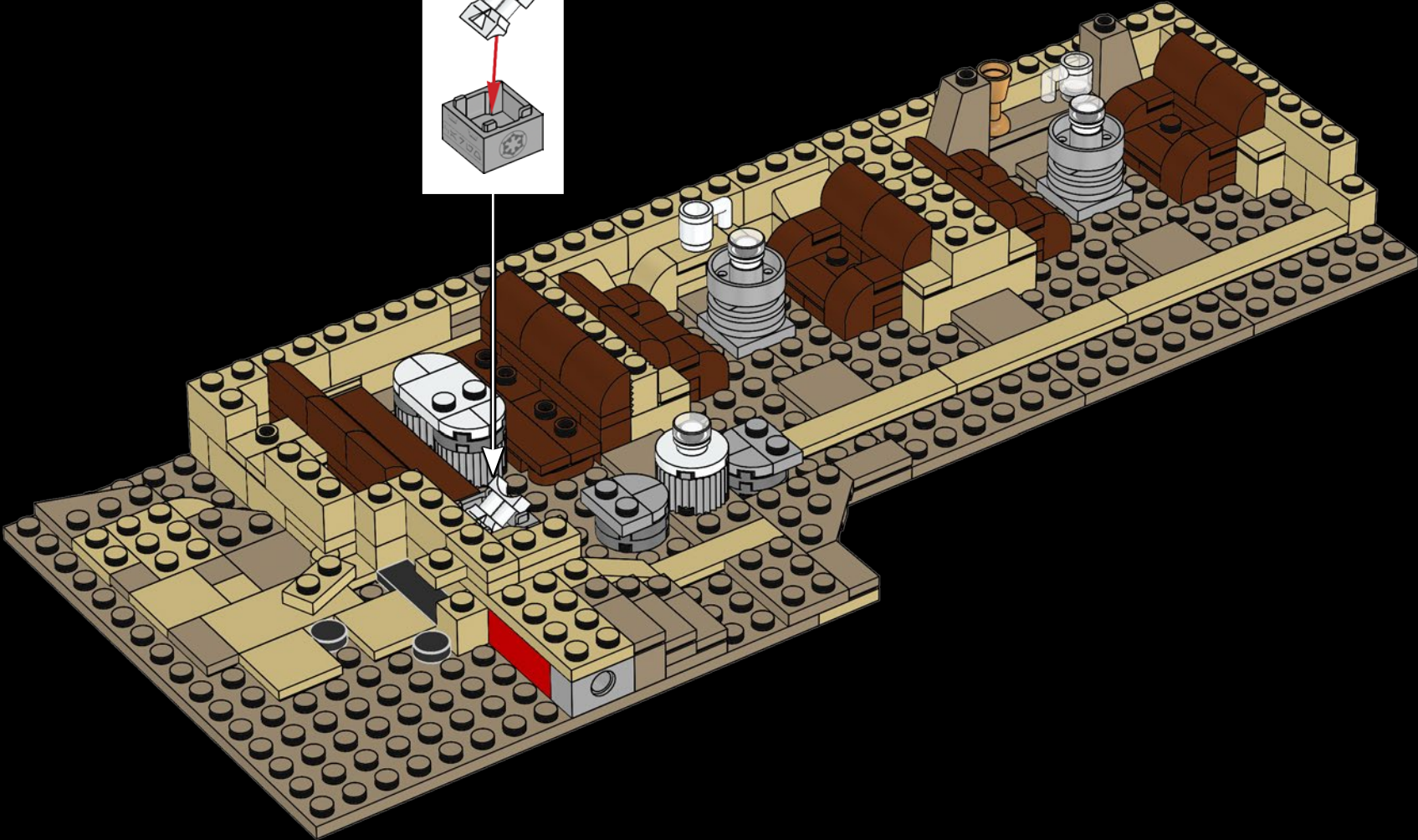
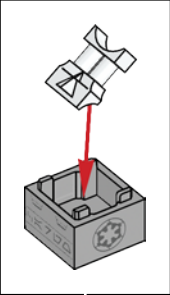

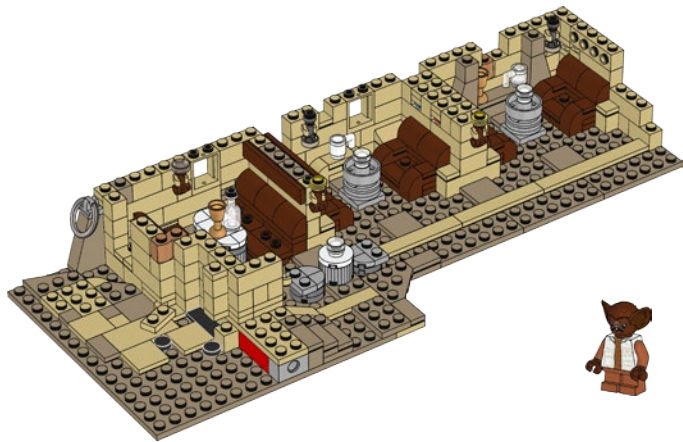

Kabe is a member of the Chadra-Fan species, bat-like sentients with big ears and dark eyes. They communicate through high-pitched squeaks which is also an effective way for Kabe to get the attention of Wuher, the Cantina's bartender. She stands only 3.2 ft. (1m) tall.

Kabe fait partie des Chadra-Fans, une espèce d'êtres sensibles ressemblant à des chauves-souris, avec de grandes oreilles et des yeux sombres. Ils communiquent par des cris aigus, qui peuvent également servir à Kabe pour attirer l'attention de Wuher, le barman de la cantina. Kabe mesure à peine 1 mètre (3,2 pi) de hauteur.

Kabe es miembro de la especie Chadra-Fan, formada por seres que parecen murciélagos, con grandes orejas y ojos oscuros. Se comunican mediante gritos de alta frecuencia, lo que le resulta particularmente útil a Kabe para llamar la atención de Wuher, el cantinero de la cantina. Solo mide 1 m de altura.

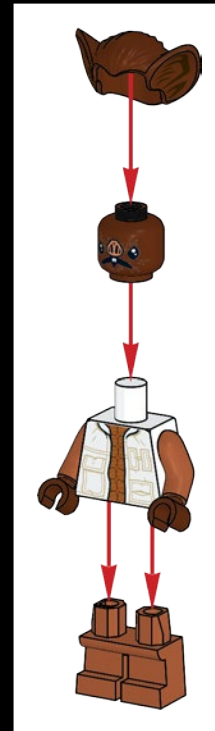

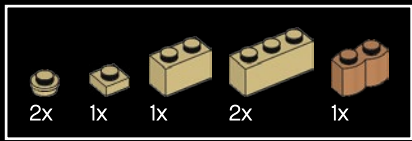

76

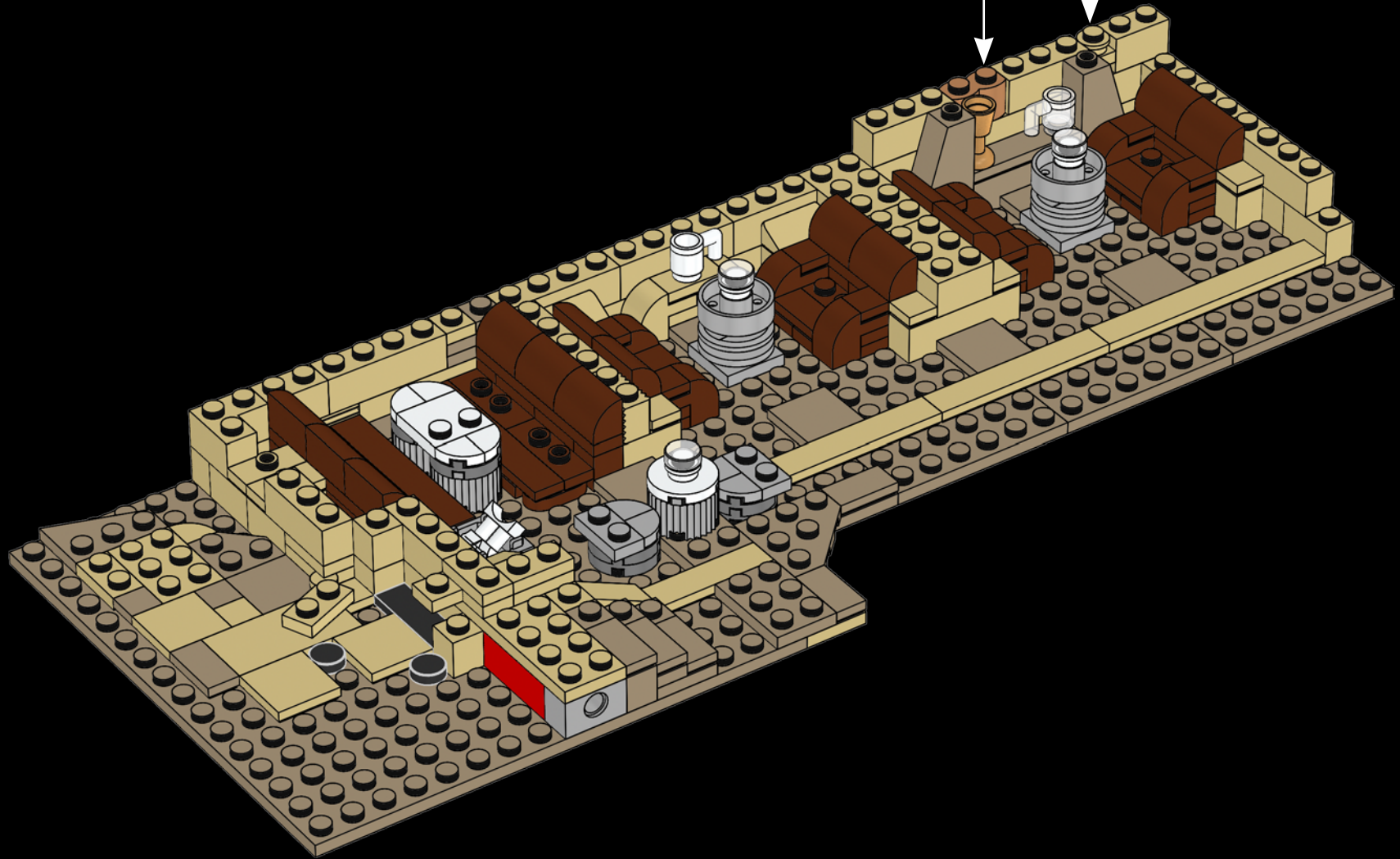
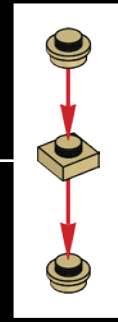
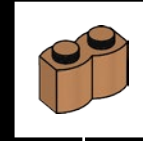

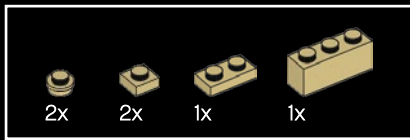

77

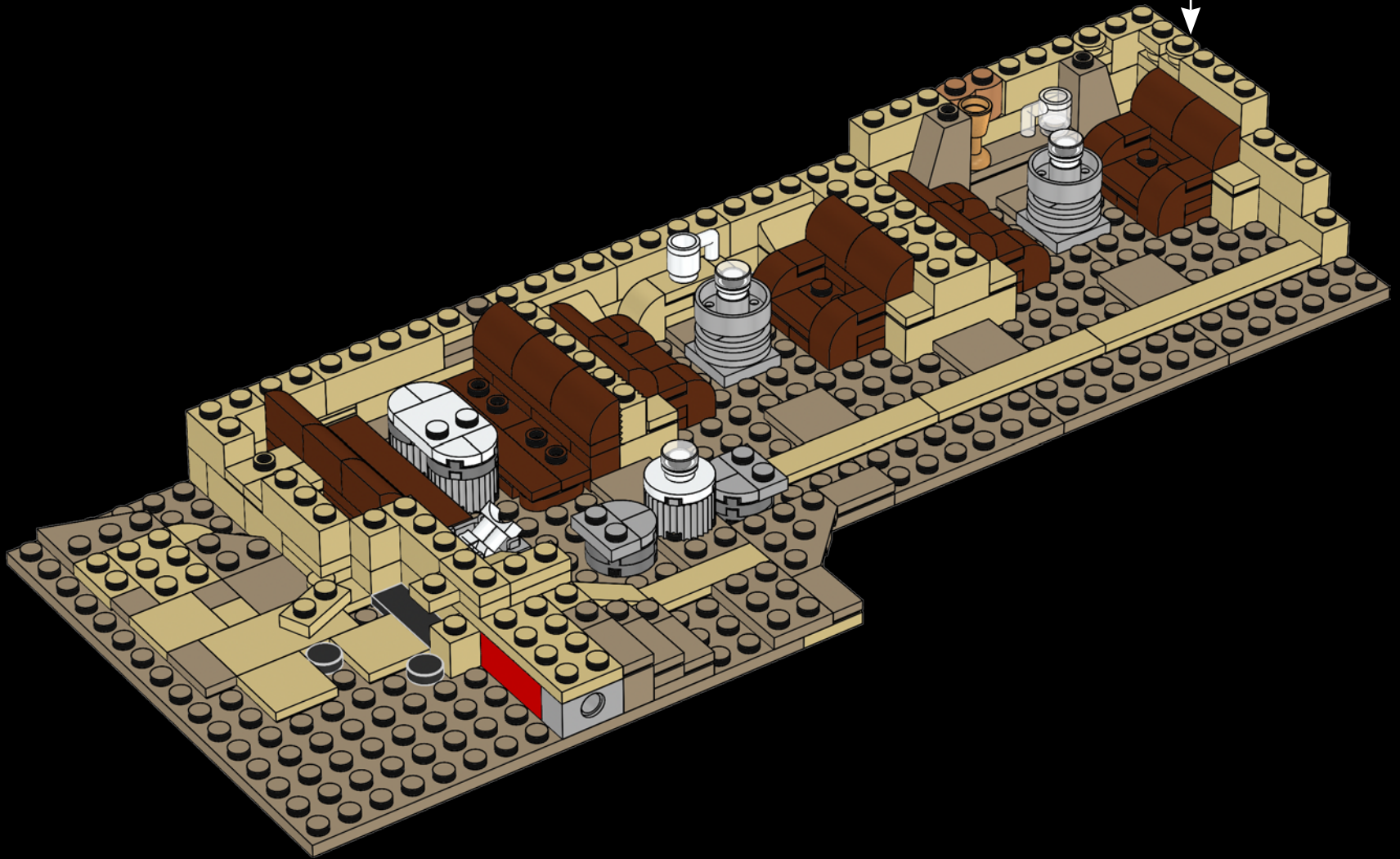
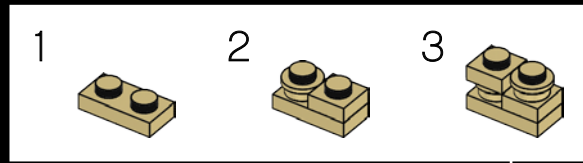

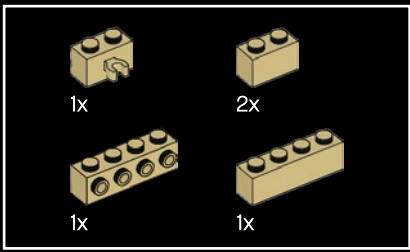

78

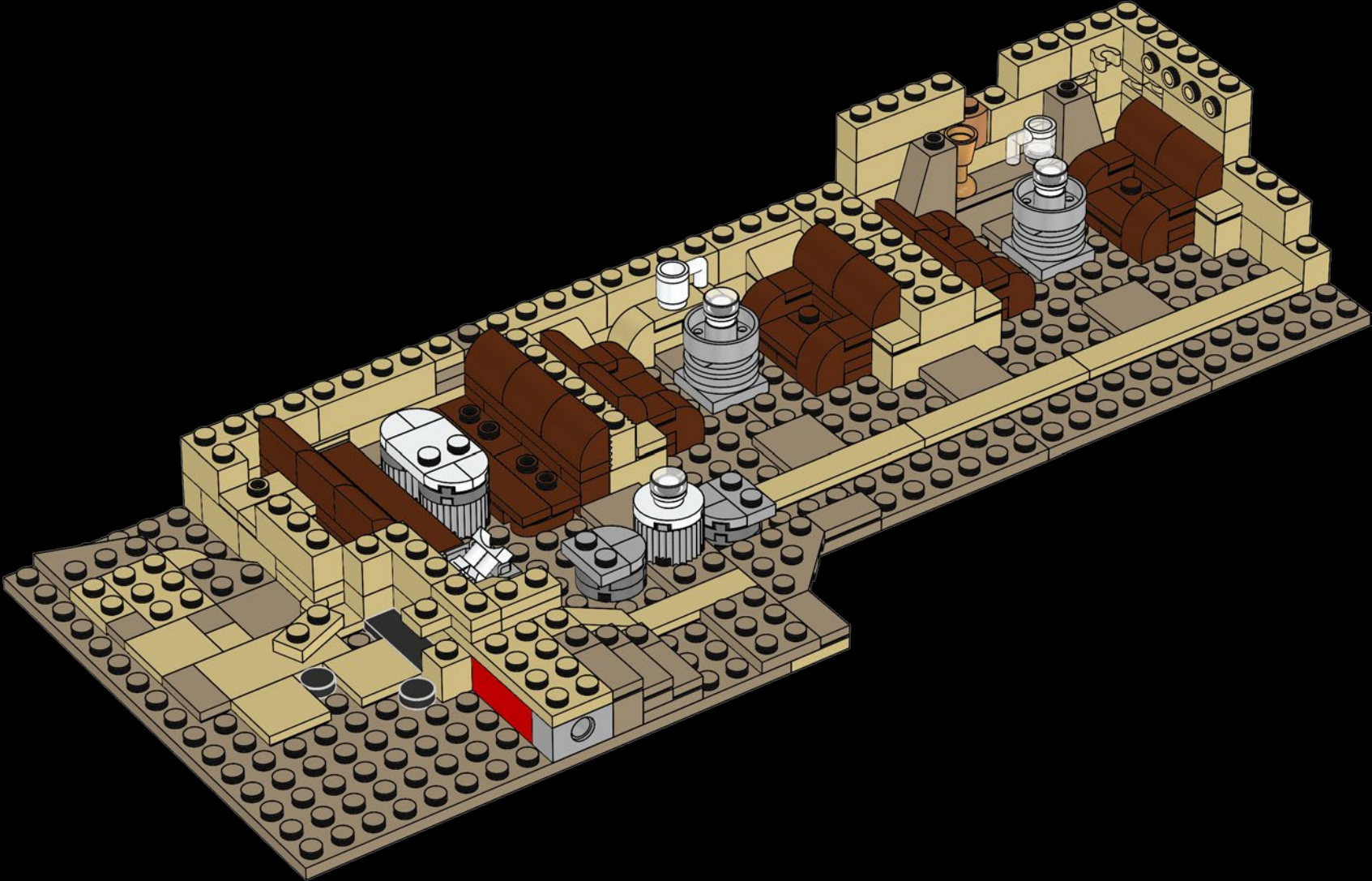

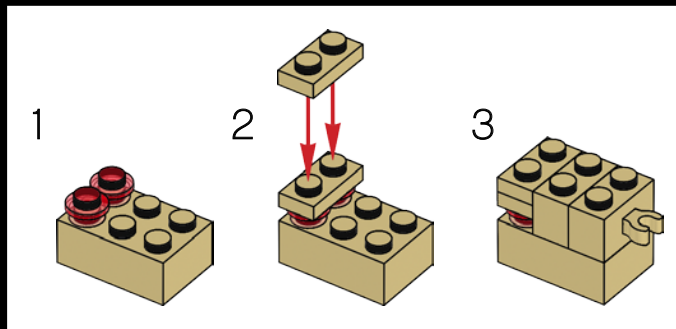
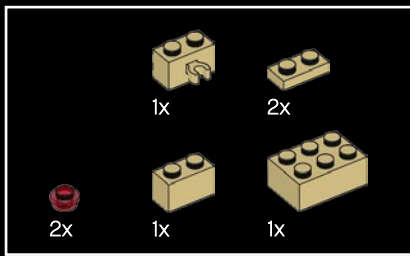

79

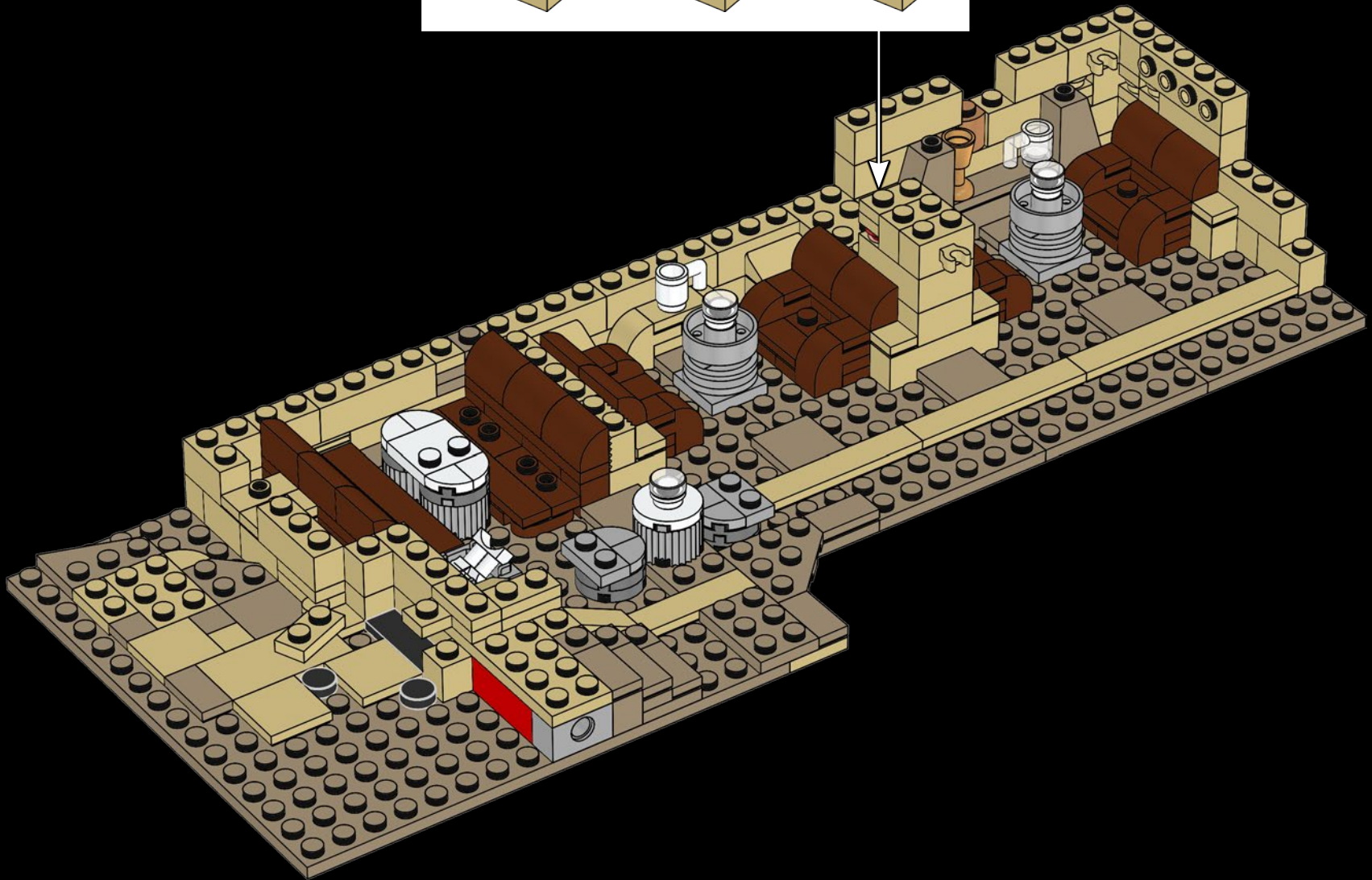

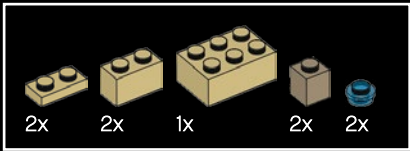

80

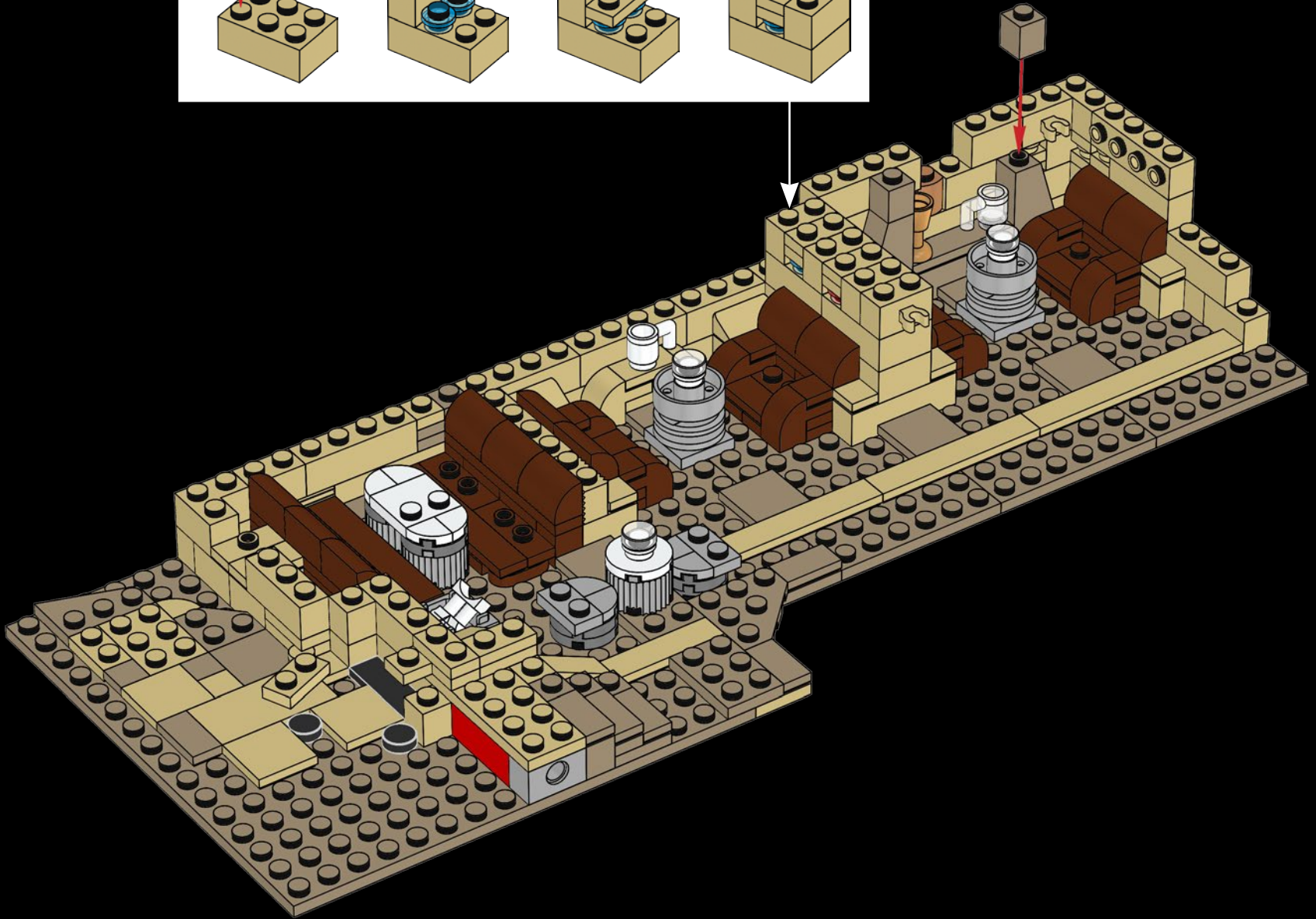
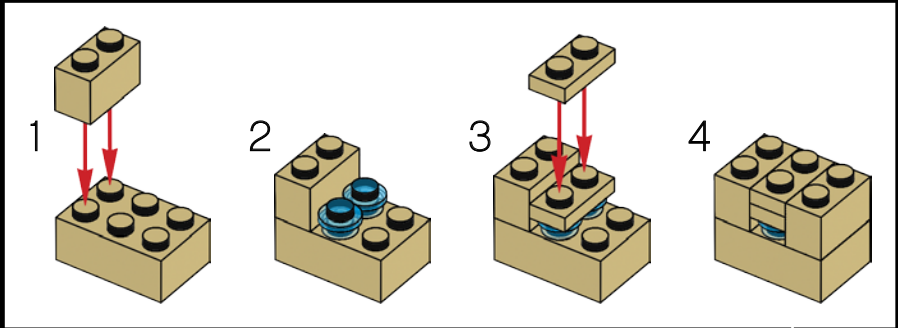

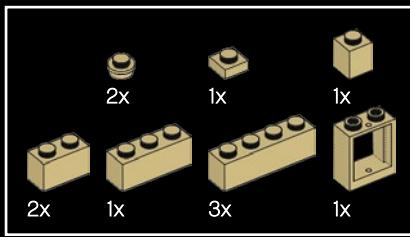

81

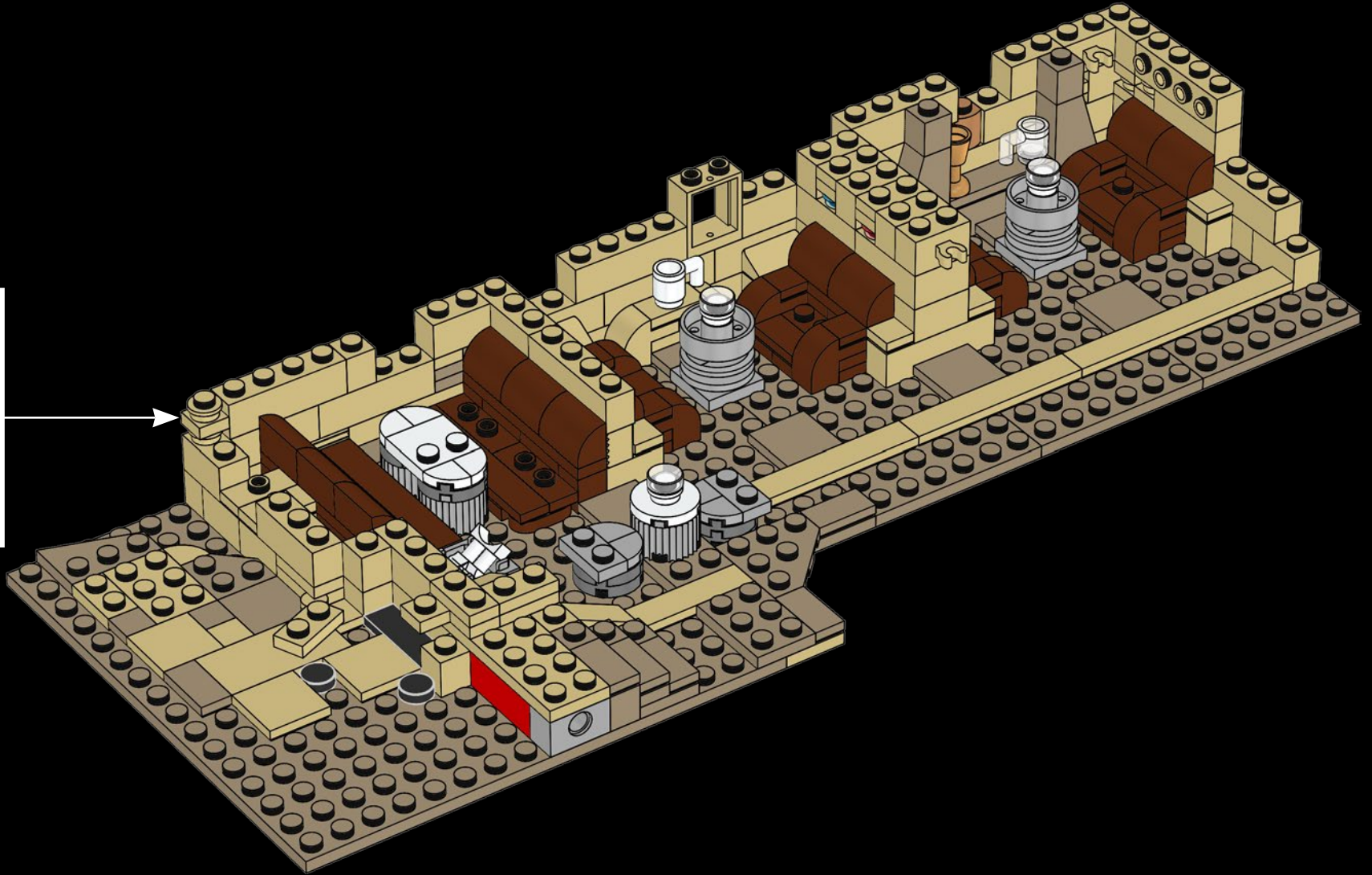
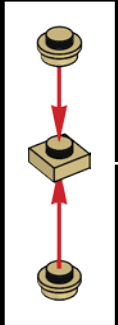

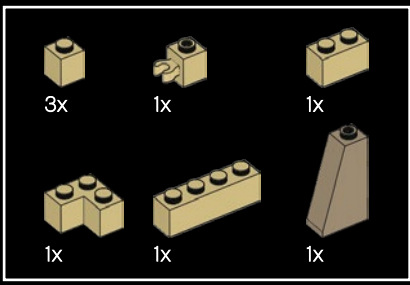

82

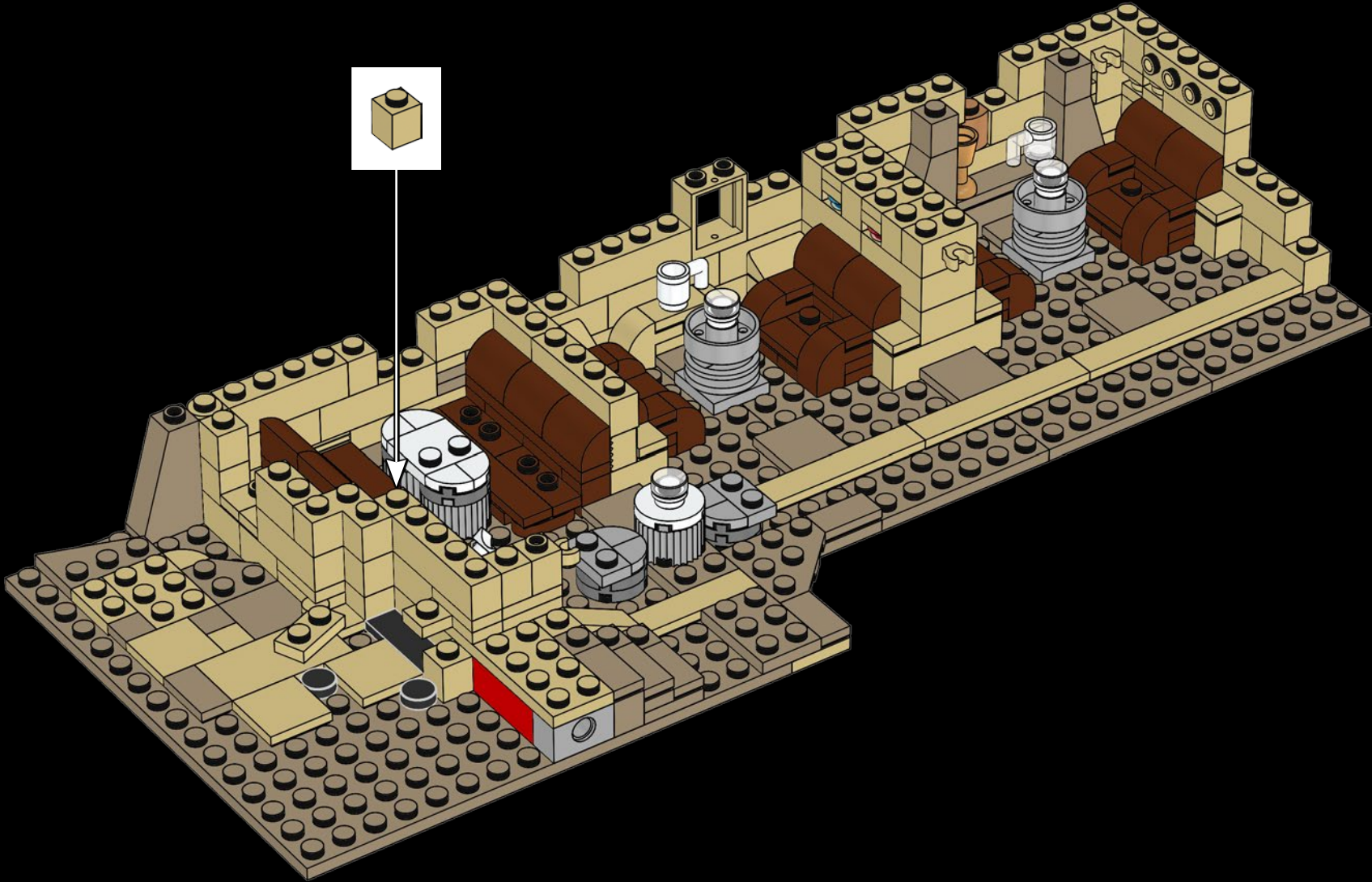

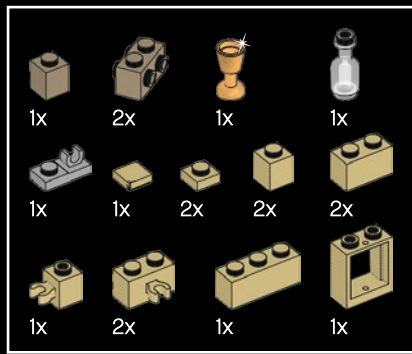

83

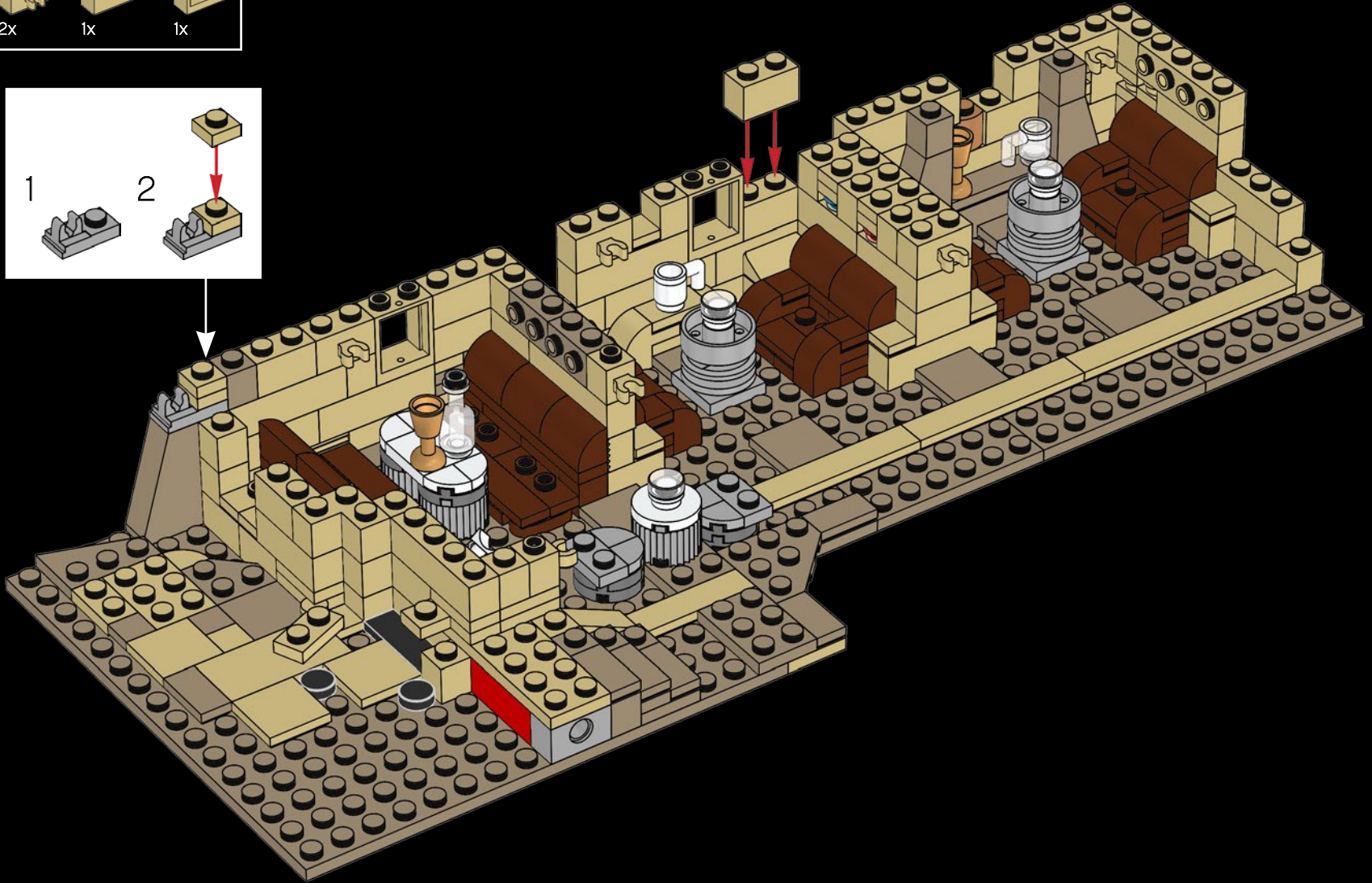
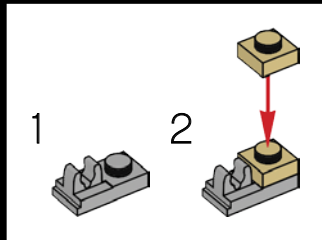

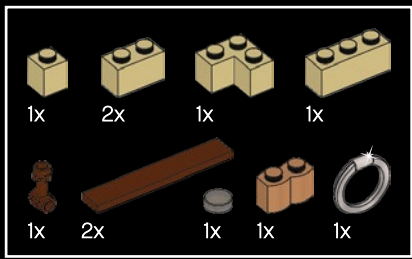

84

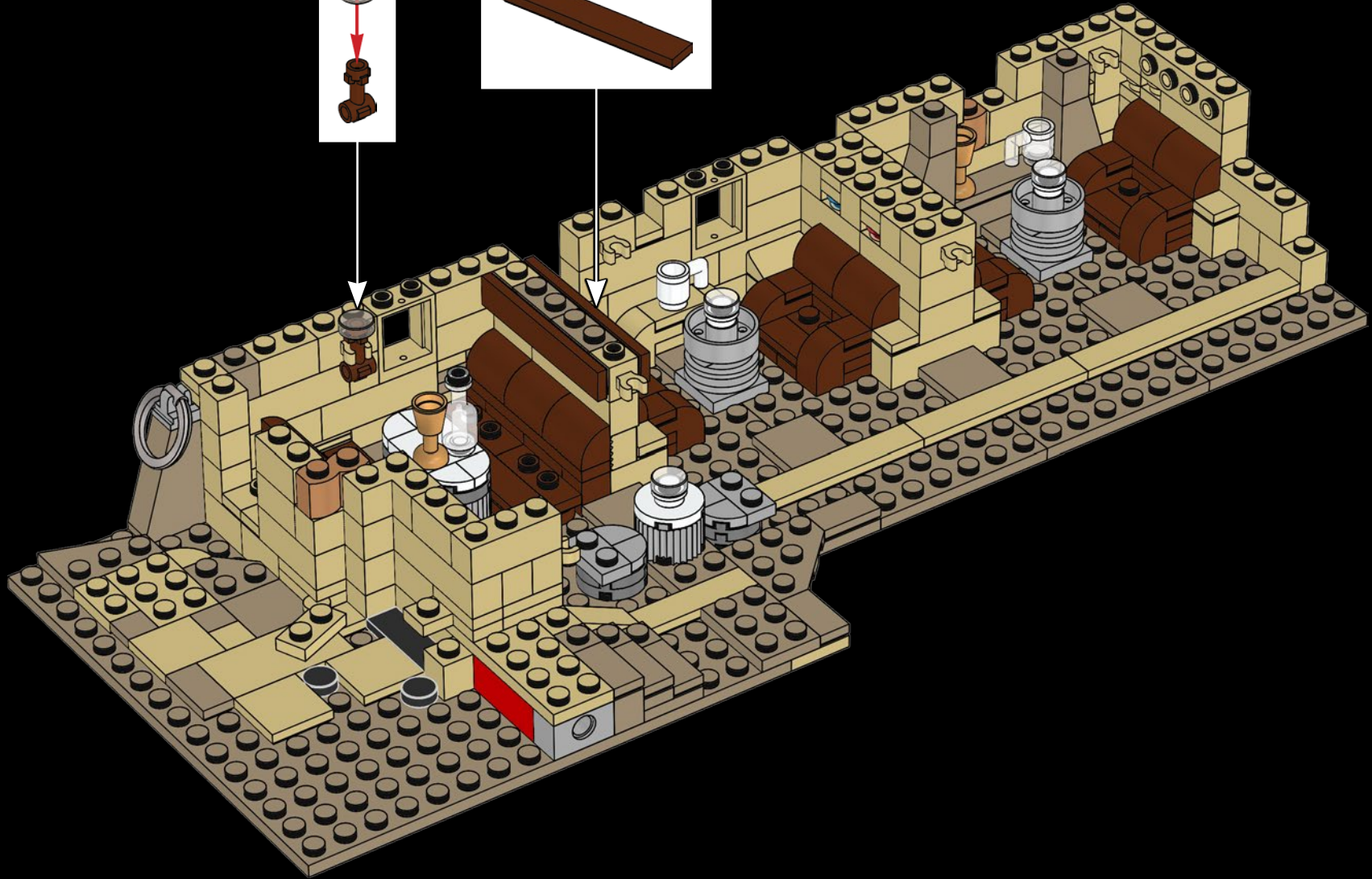
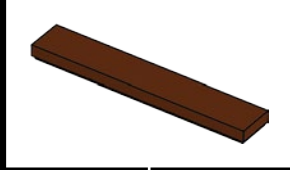
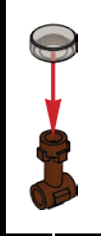



85

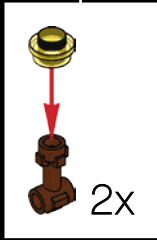
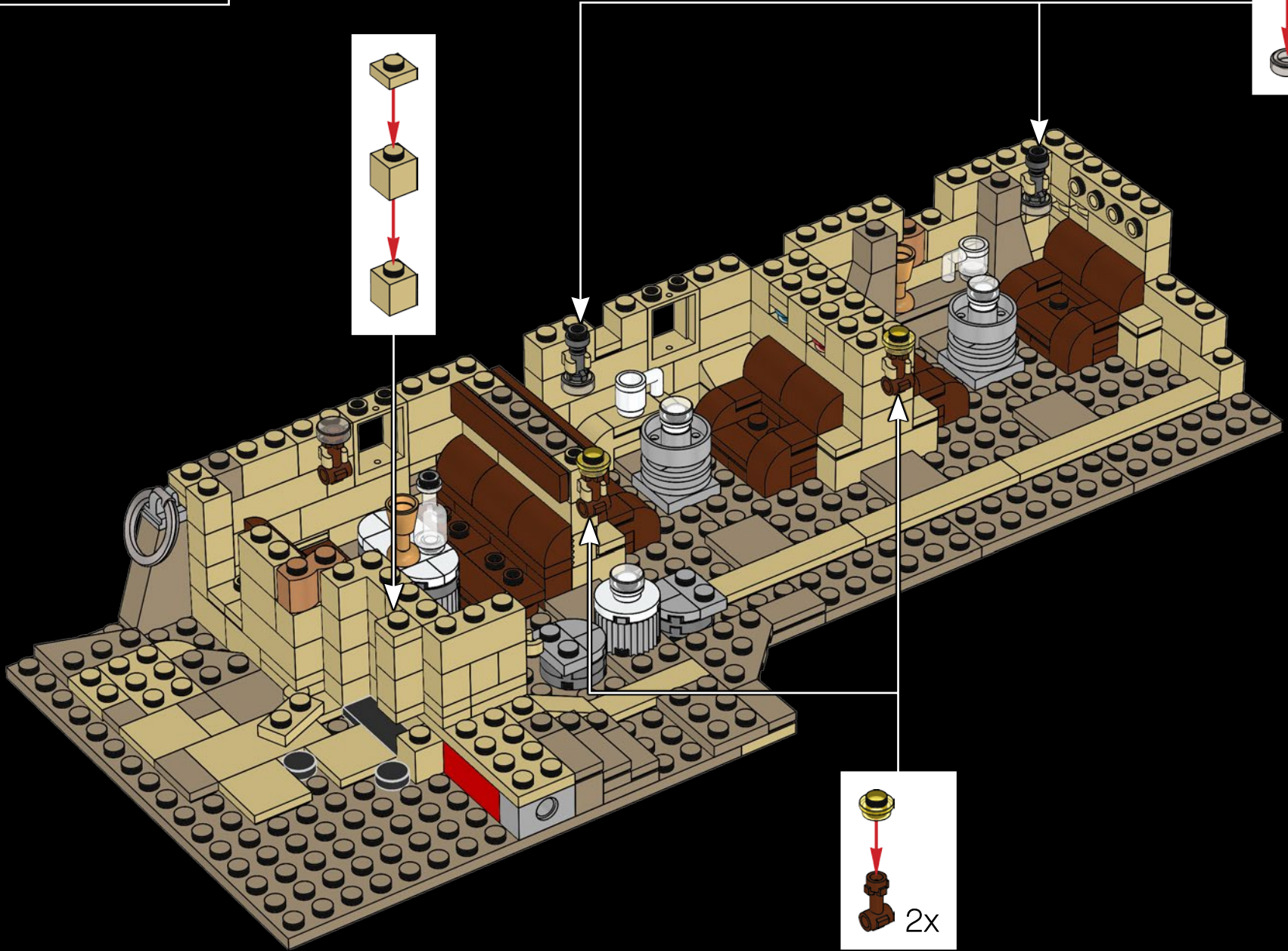
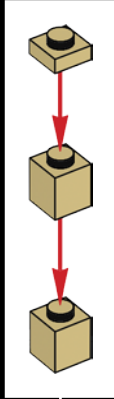
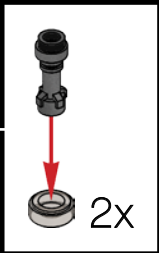

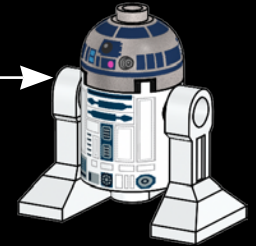
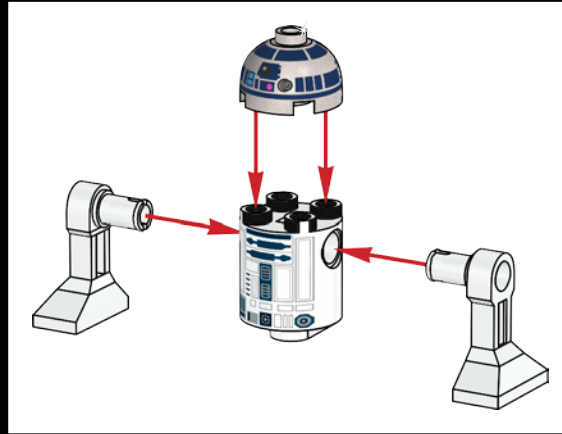
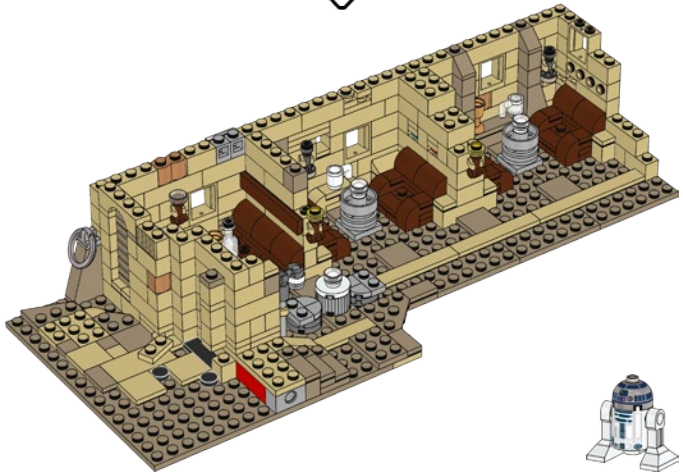
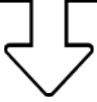
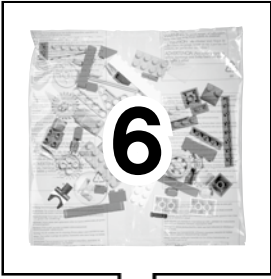

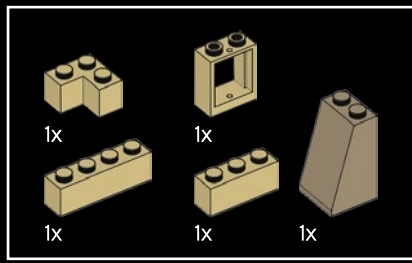

86

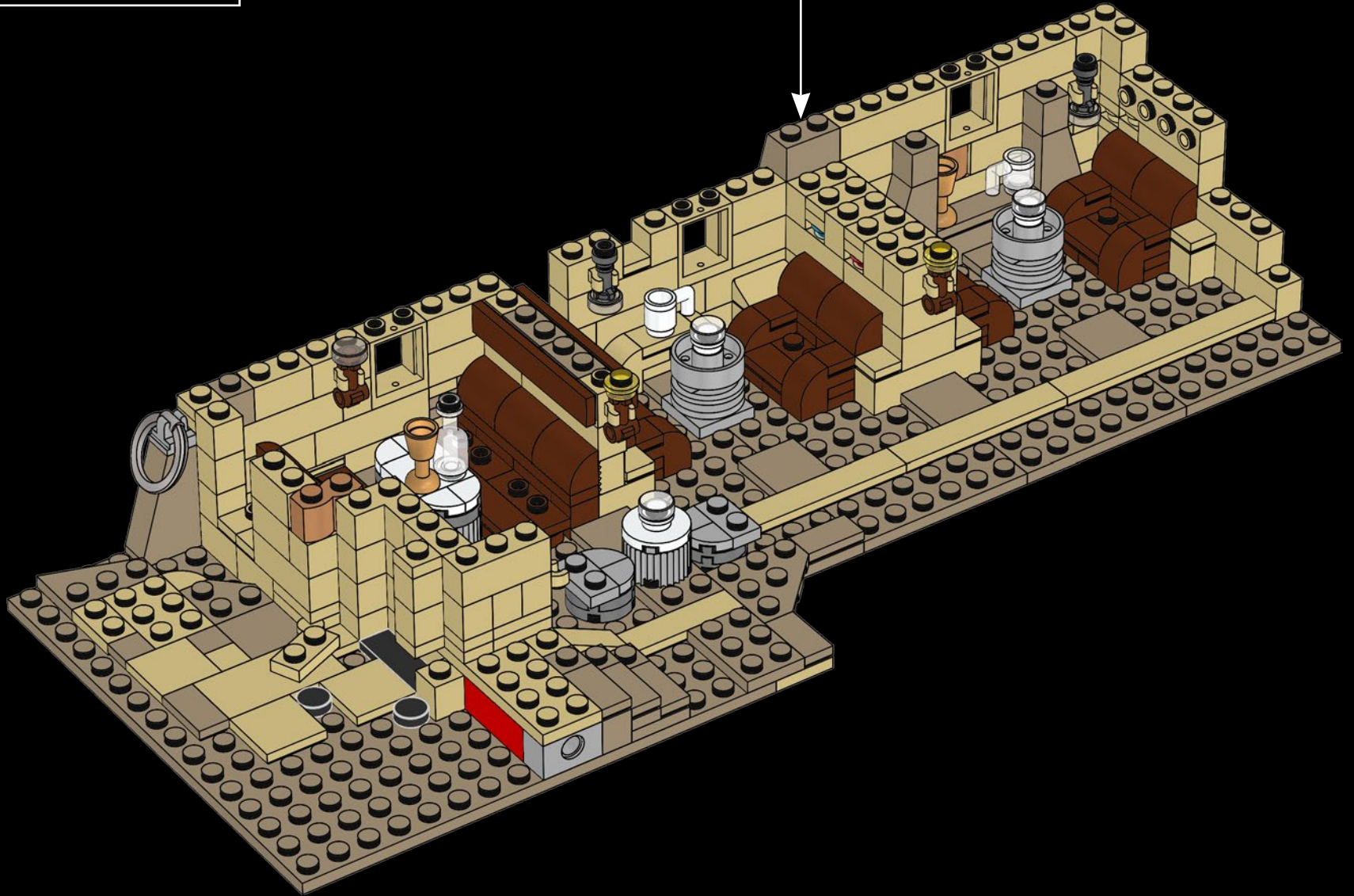
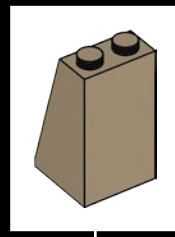

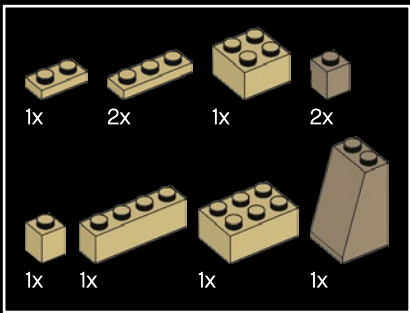

87

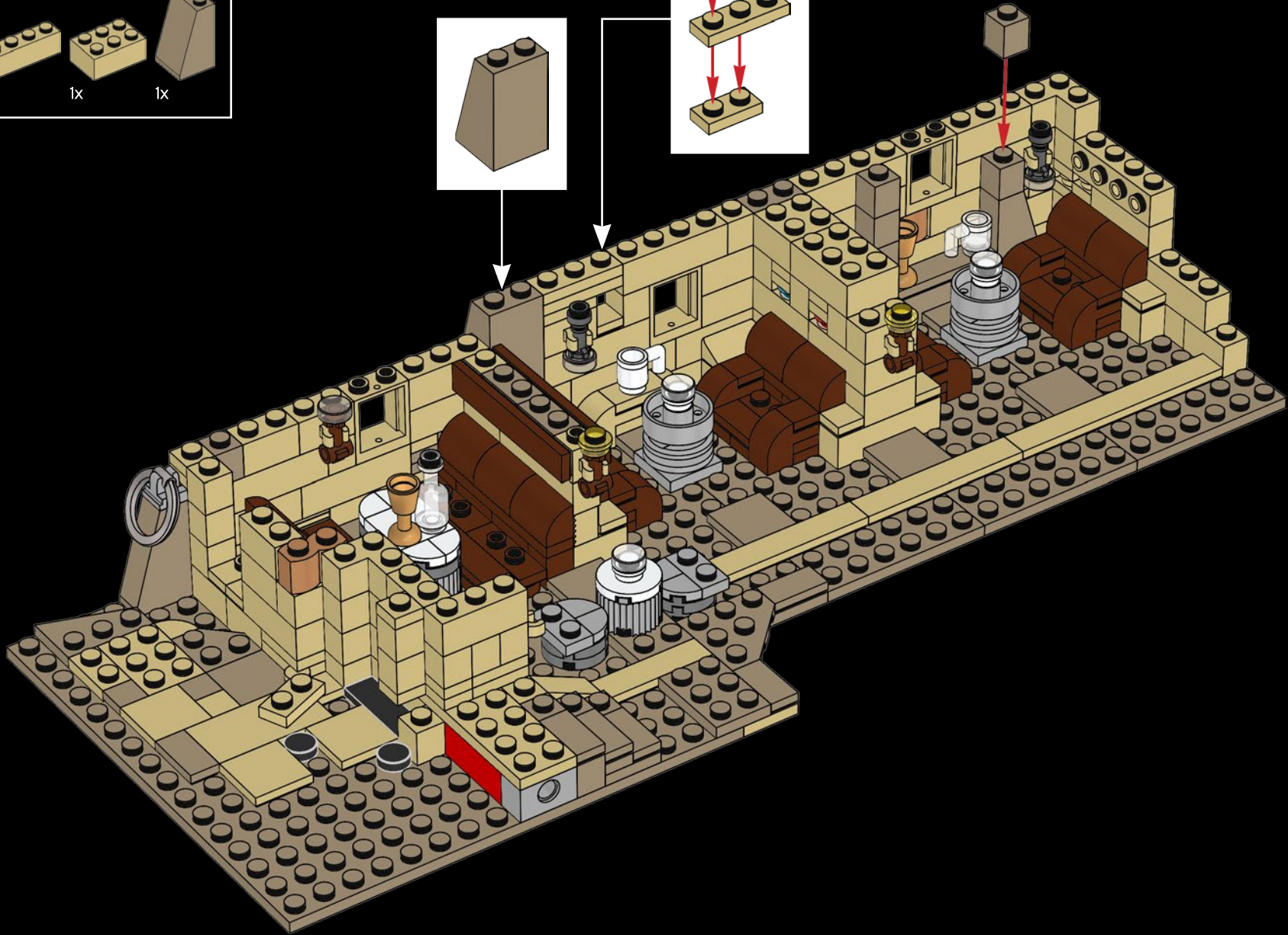
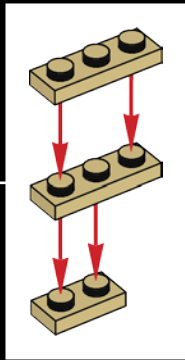
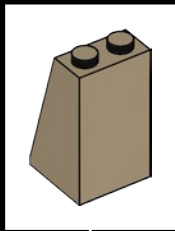

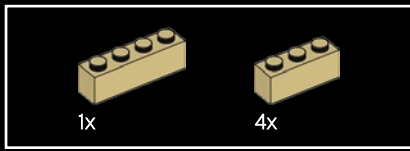

88

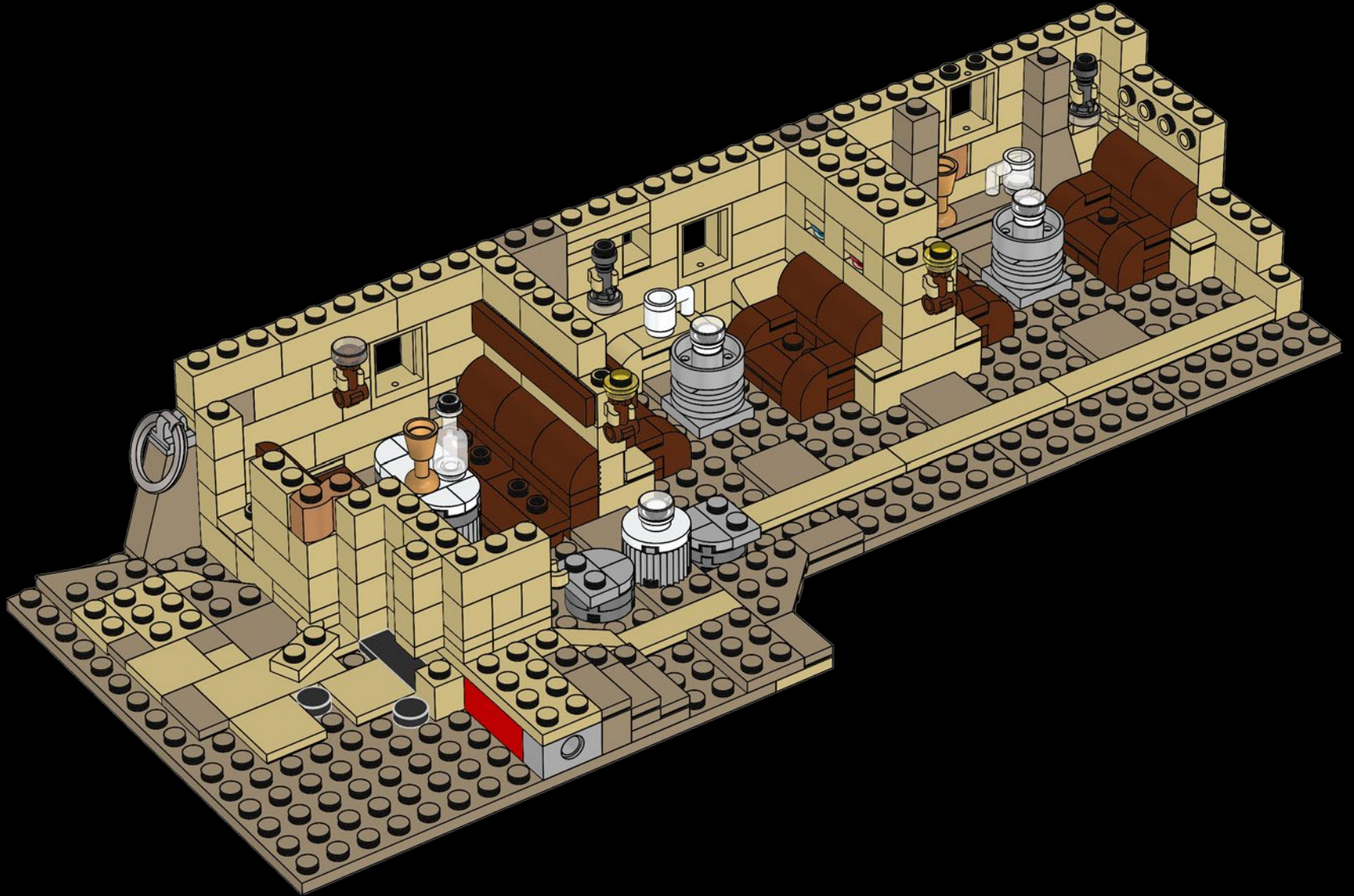

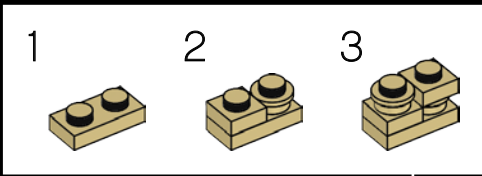
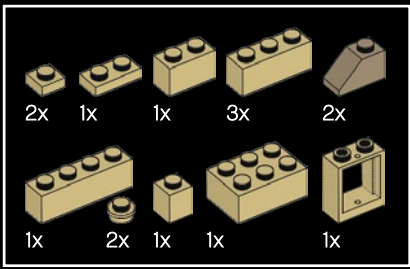

89

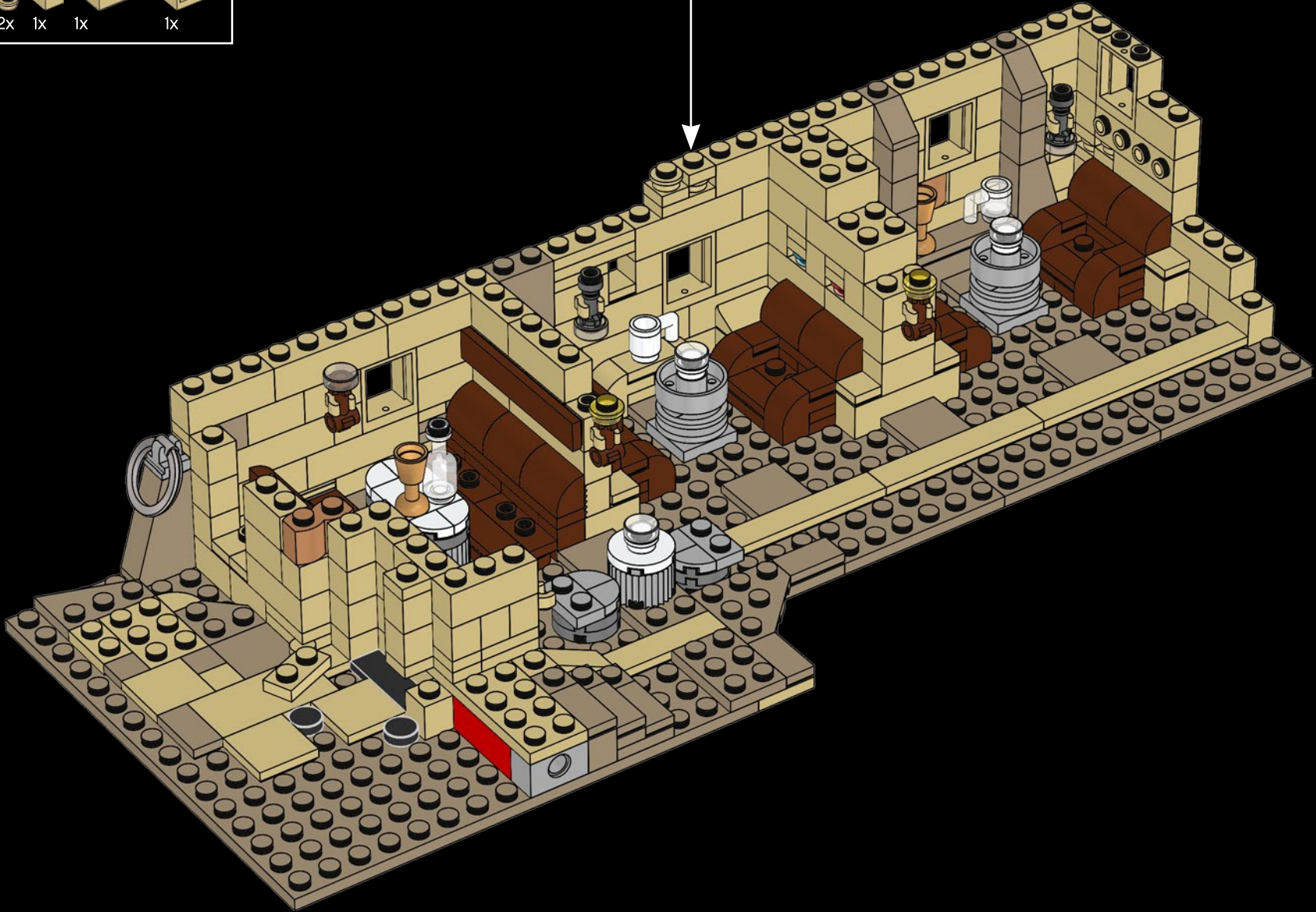

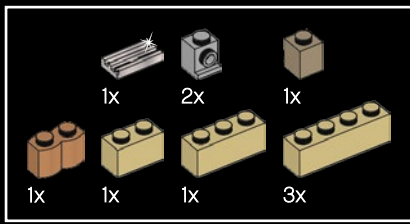

90

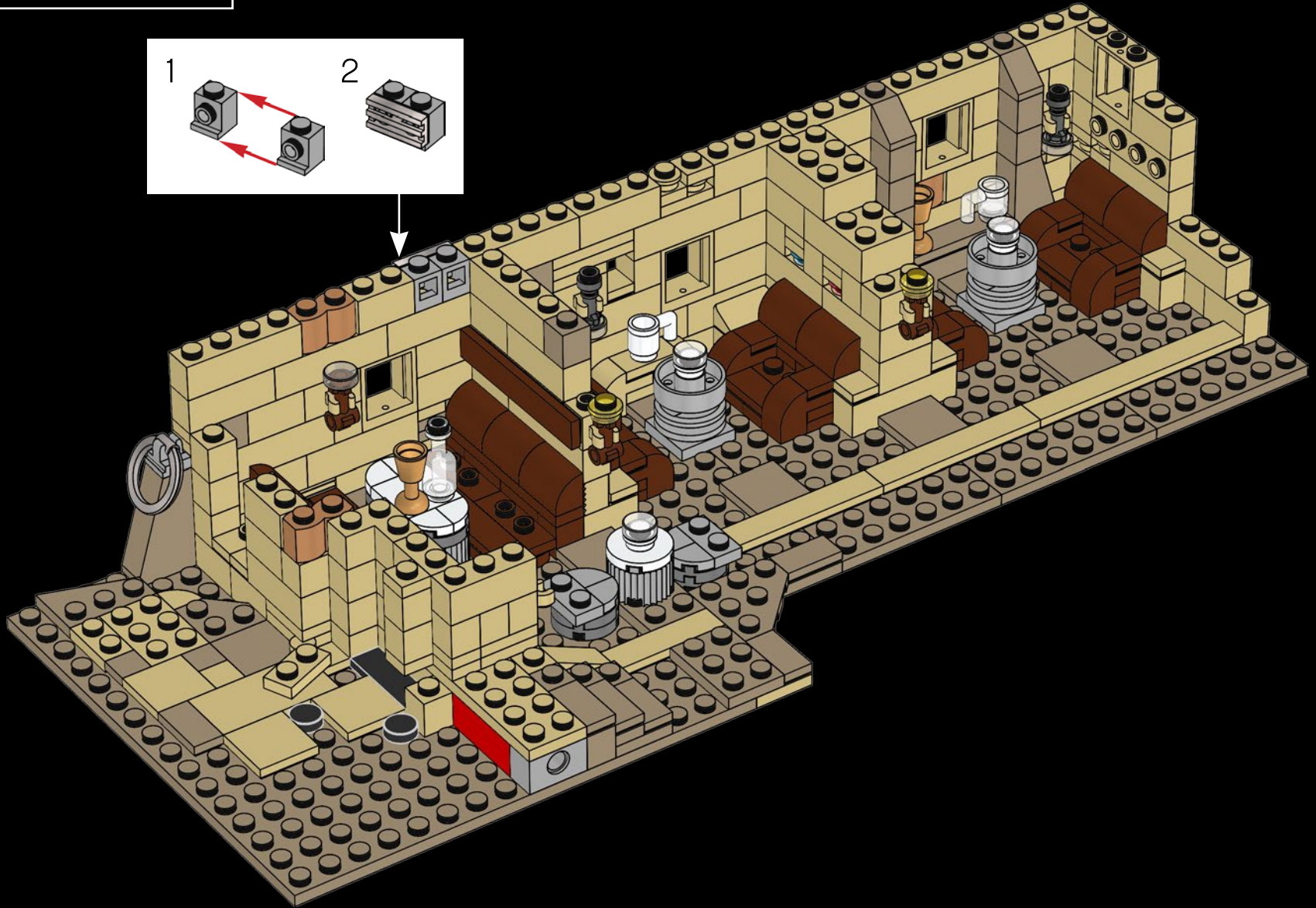
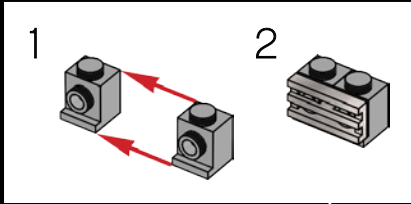



91

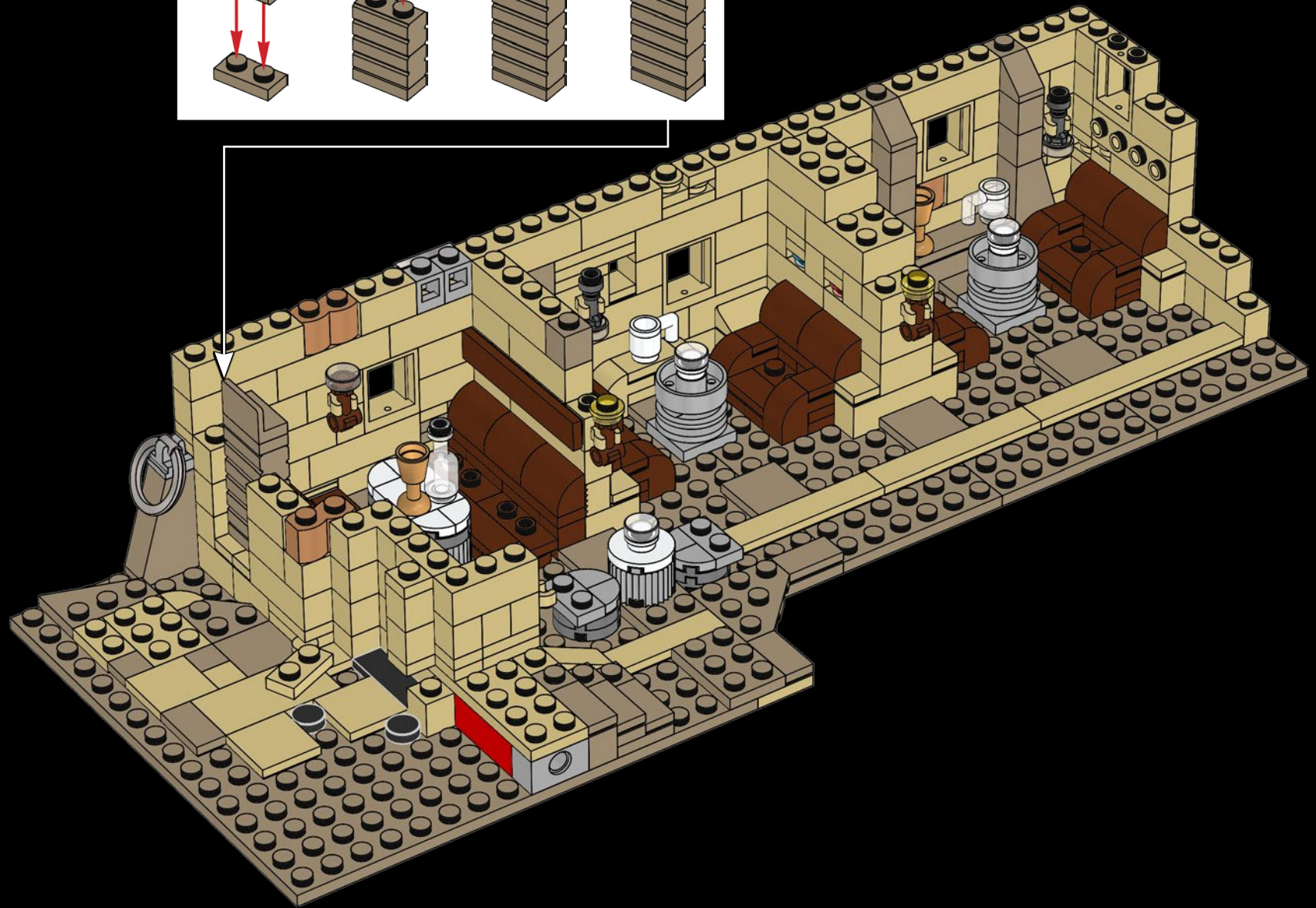
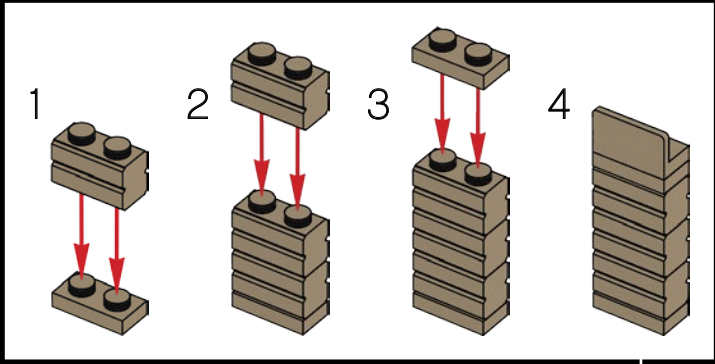

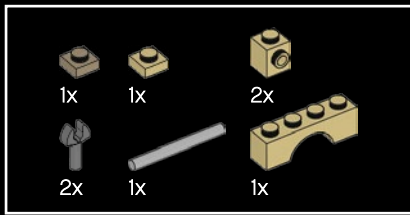

92

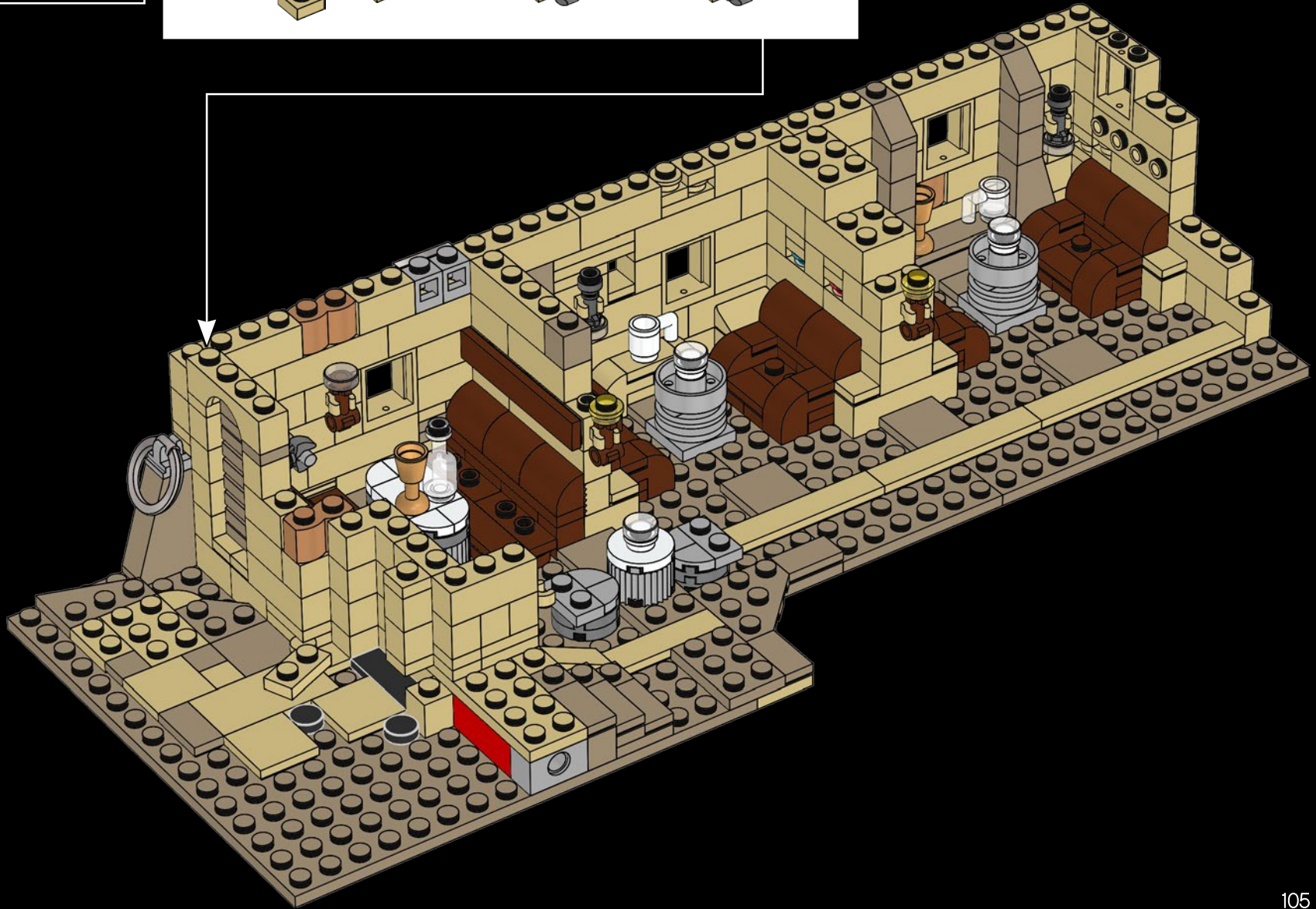
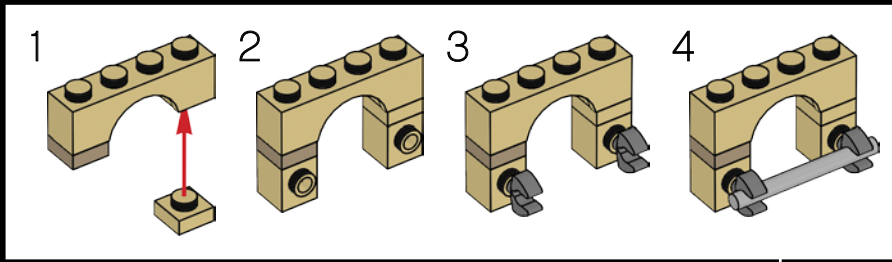



93

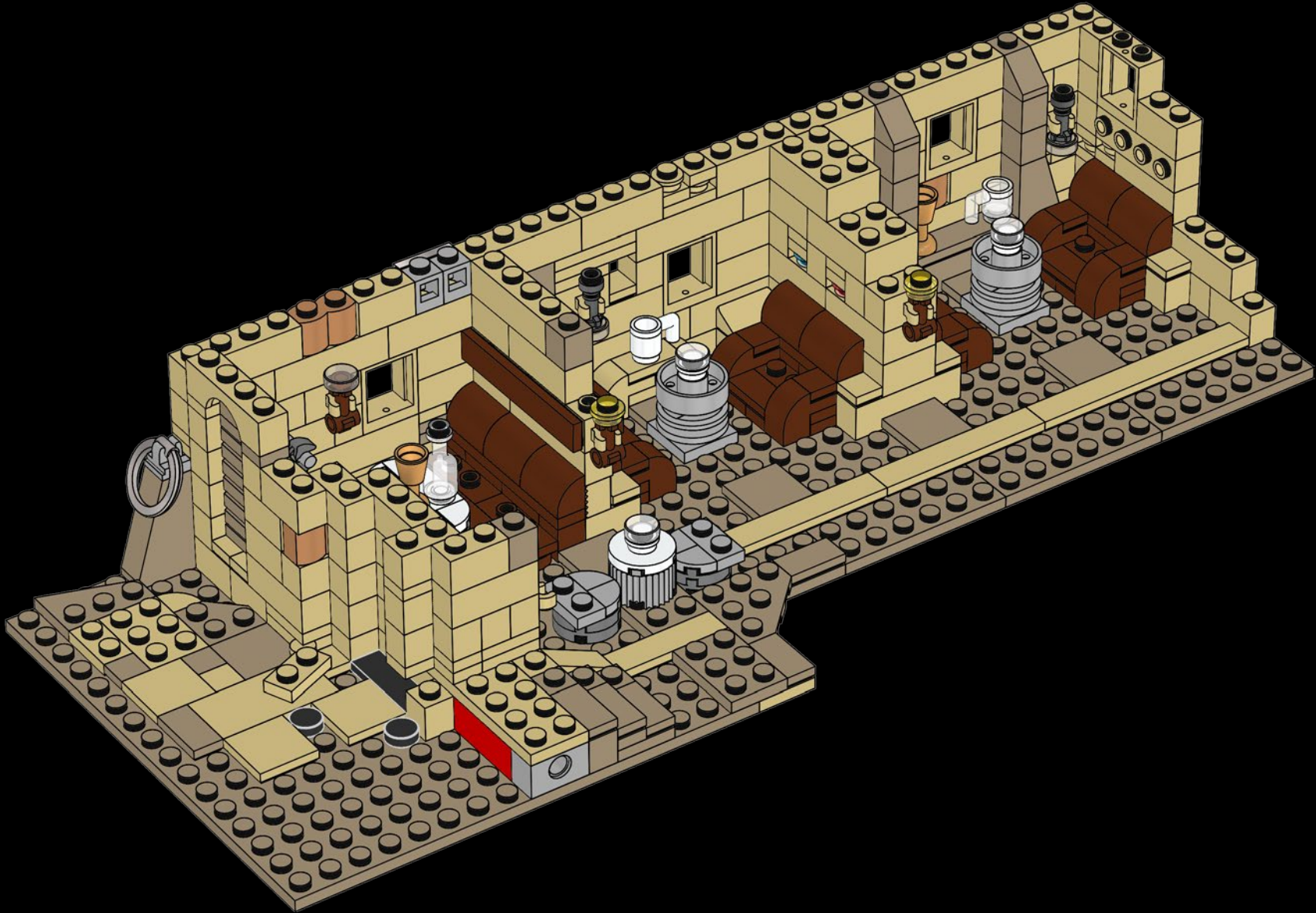

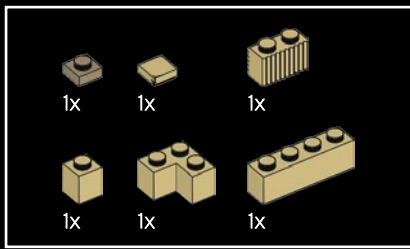

94

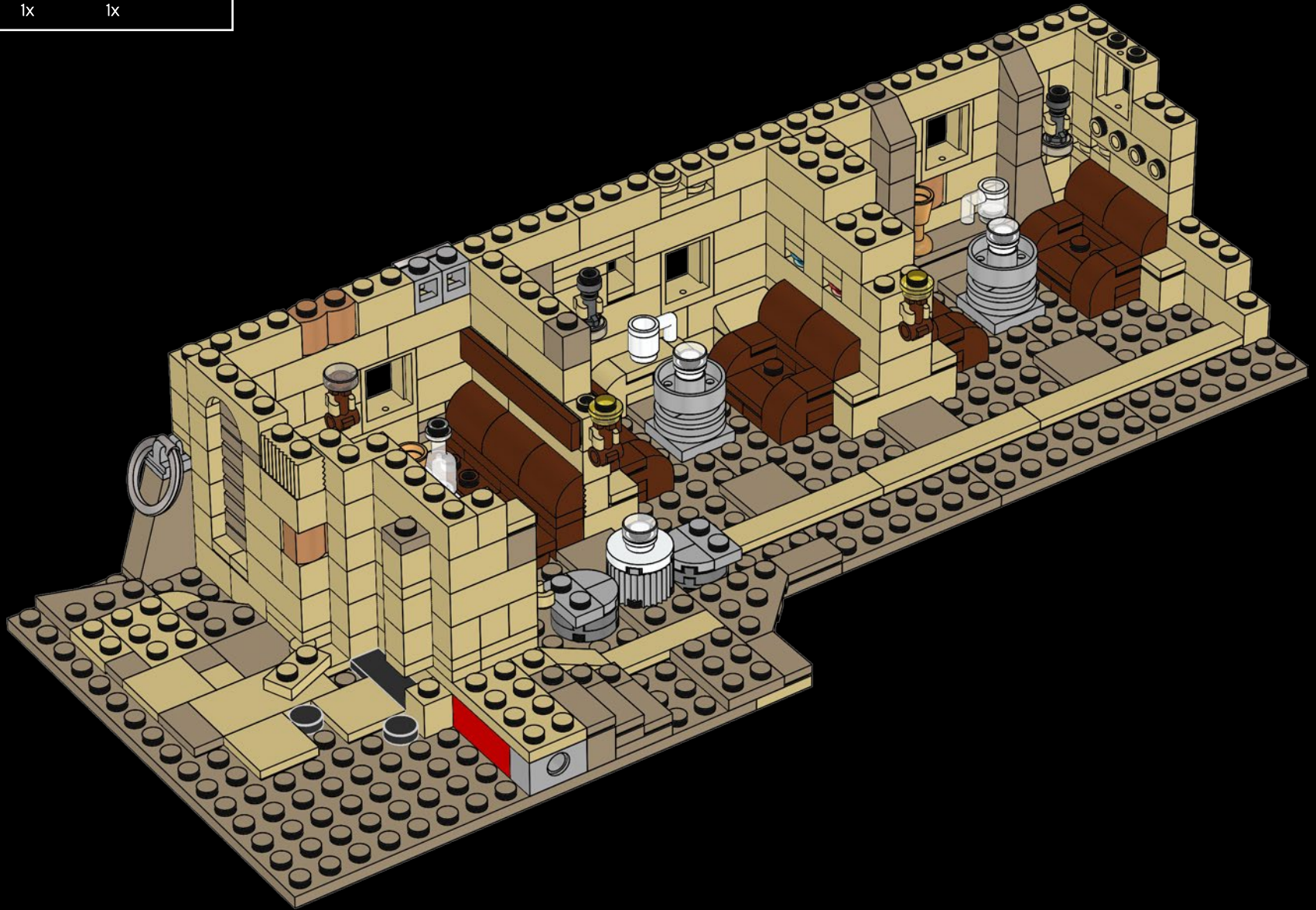

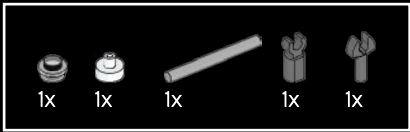

95

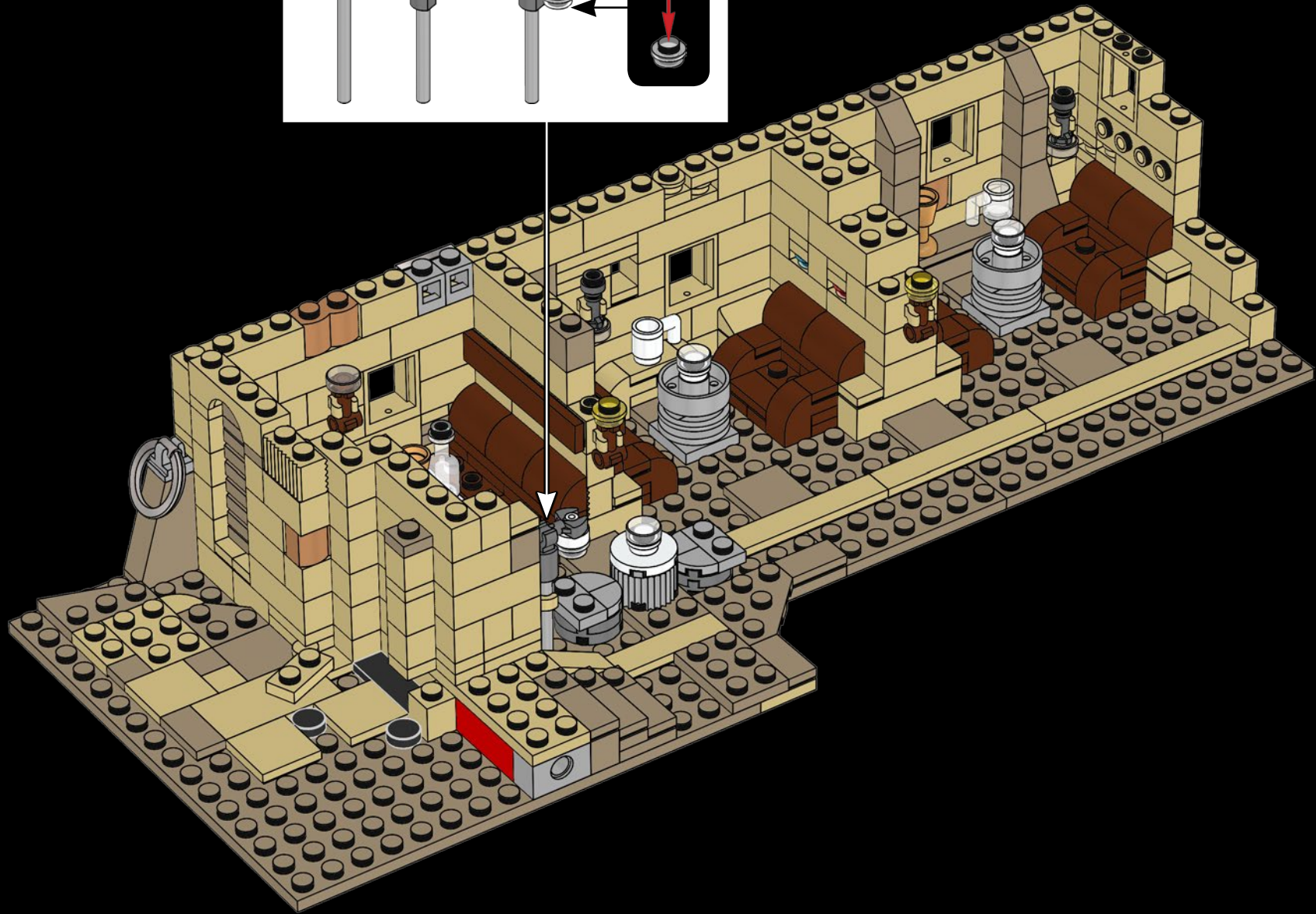
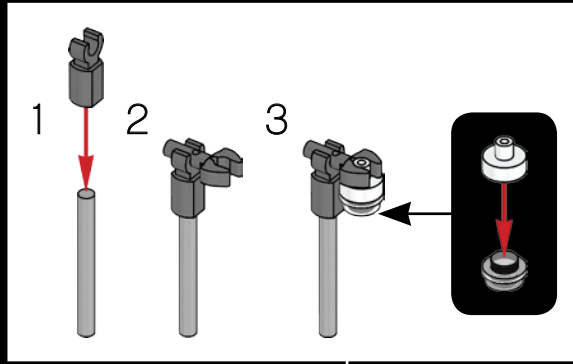

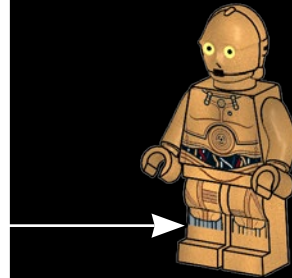
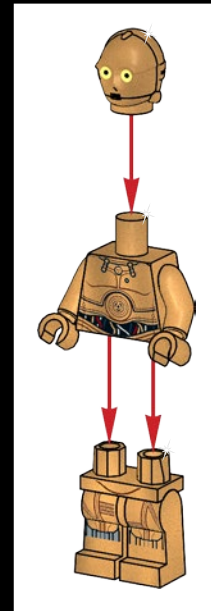
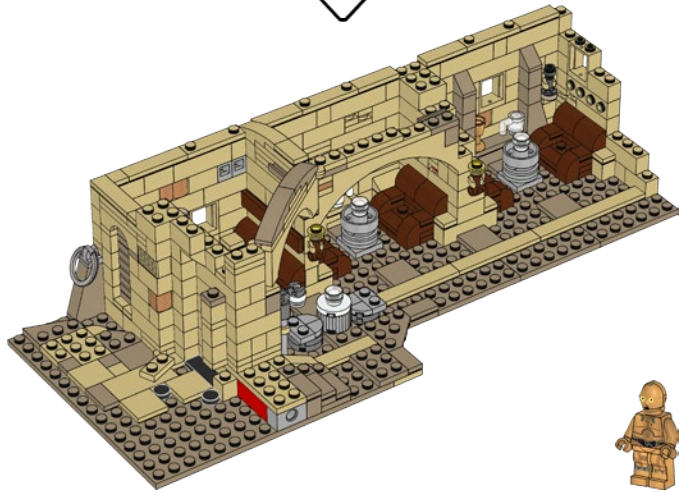
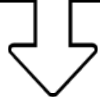

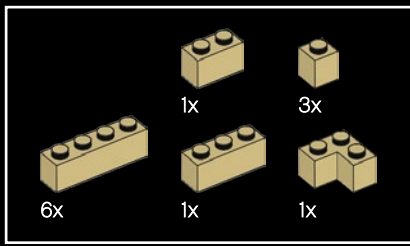

96



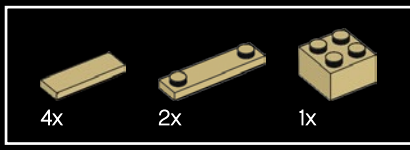

97

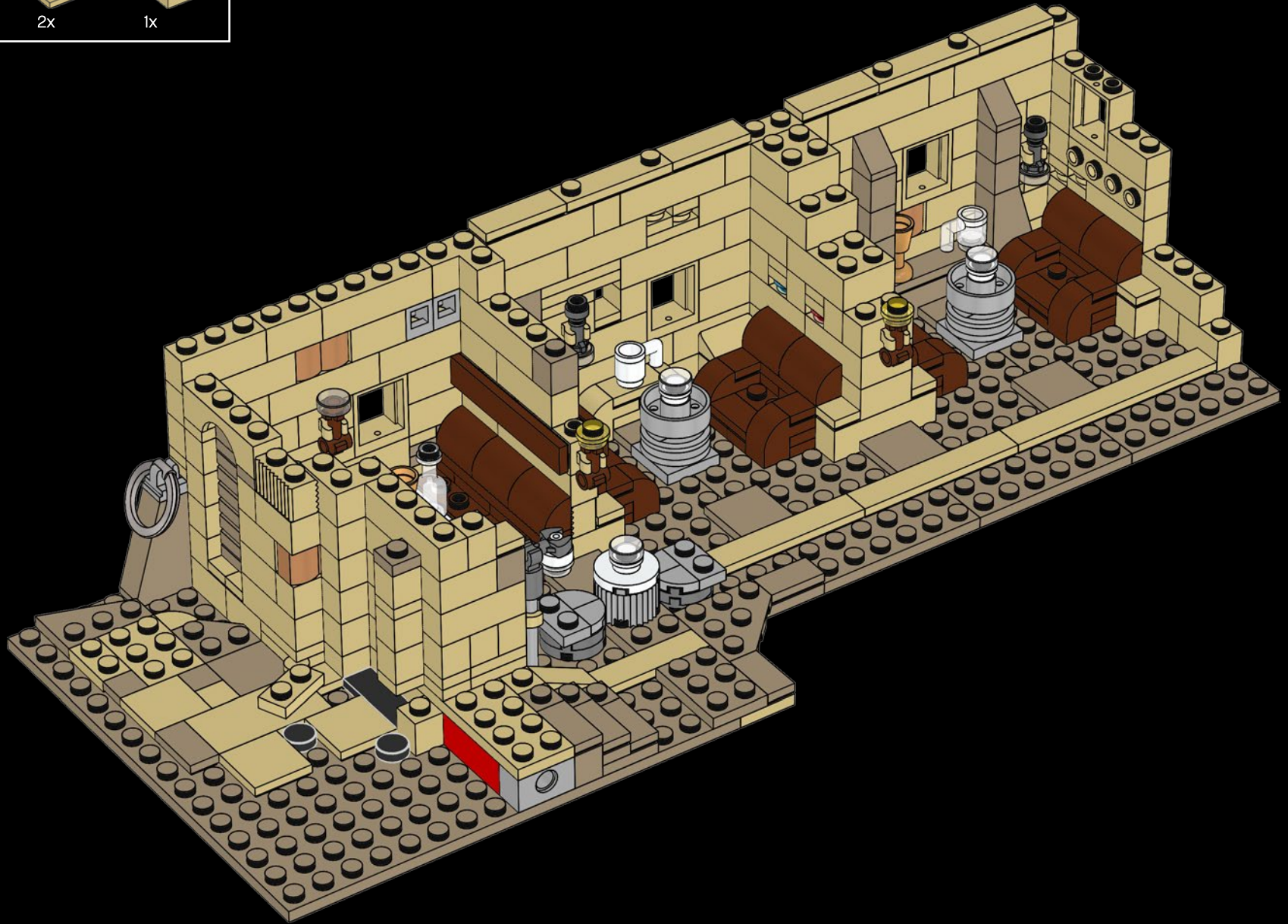

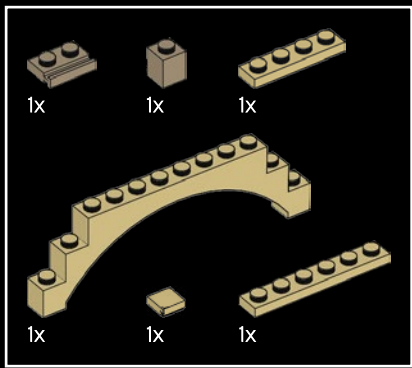

98

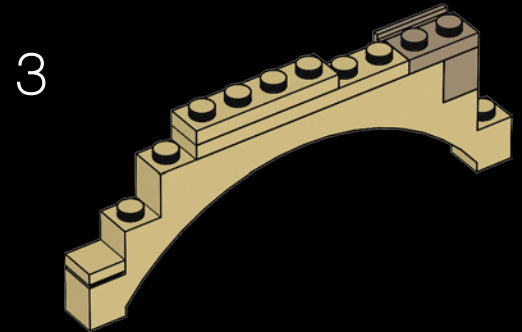
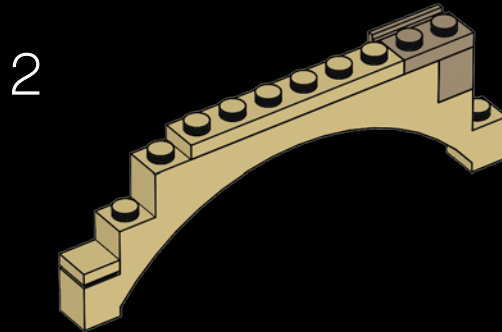
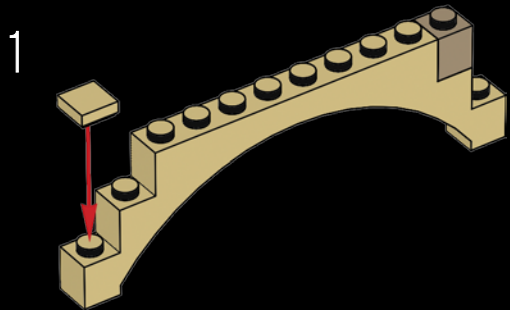

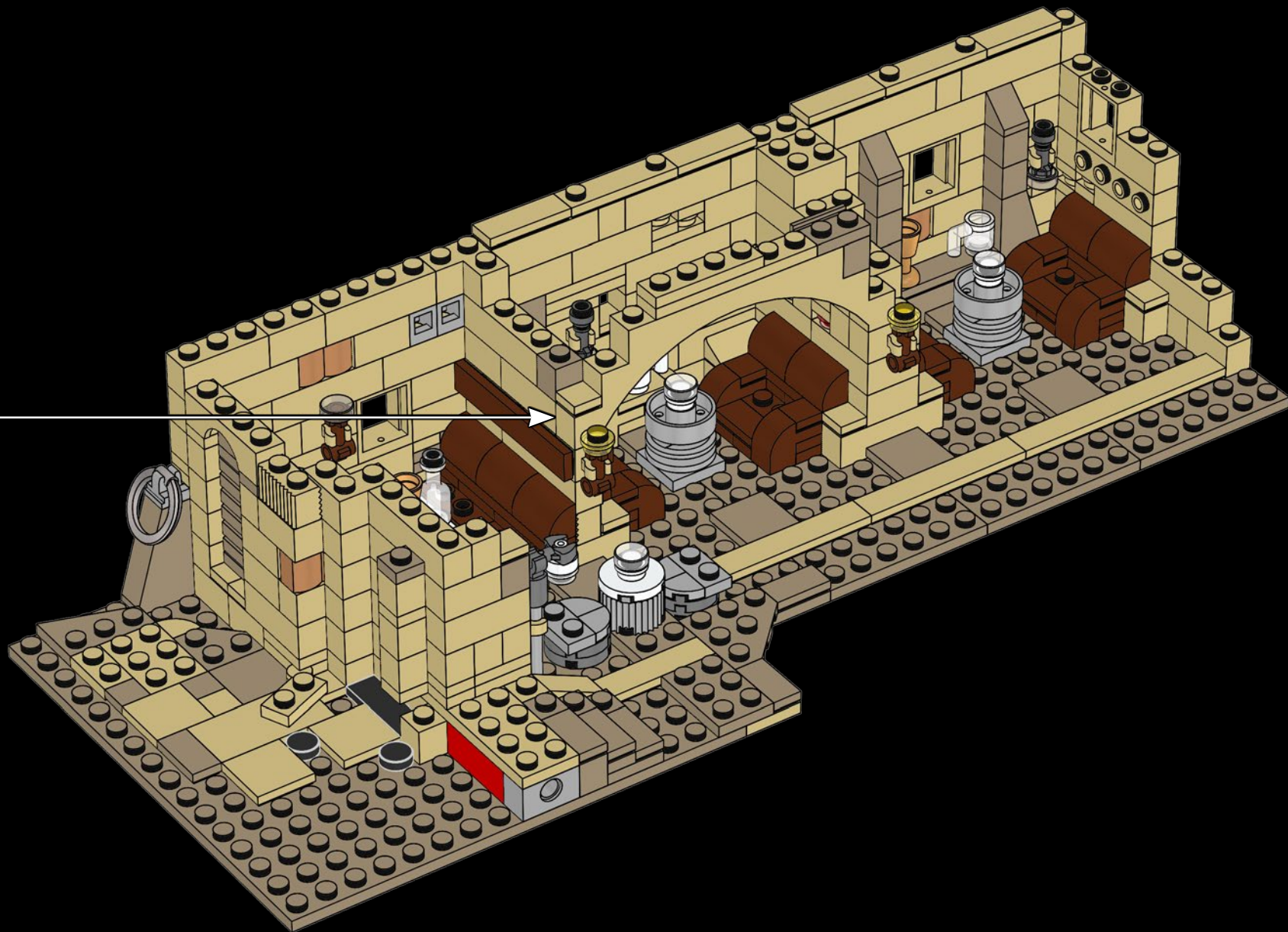

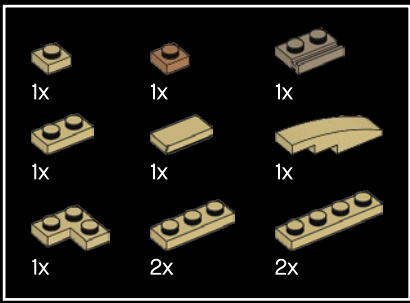

99

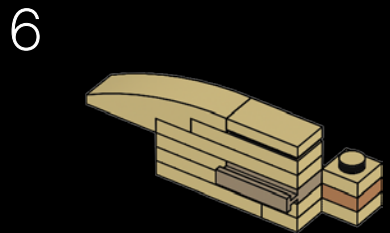
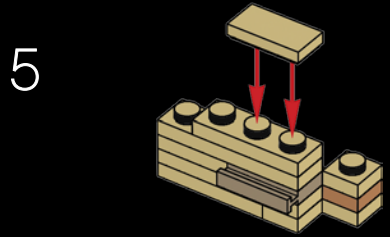
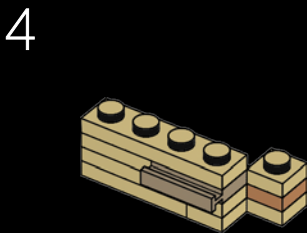
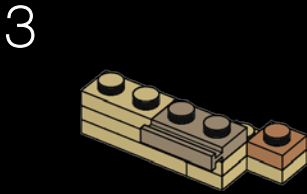
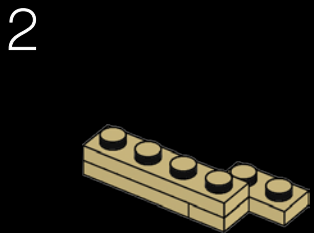
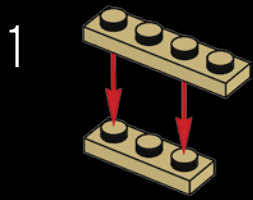

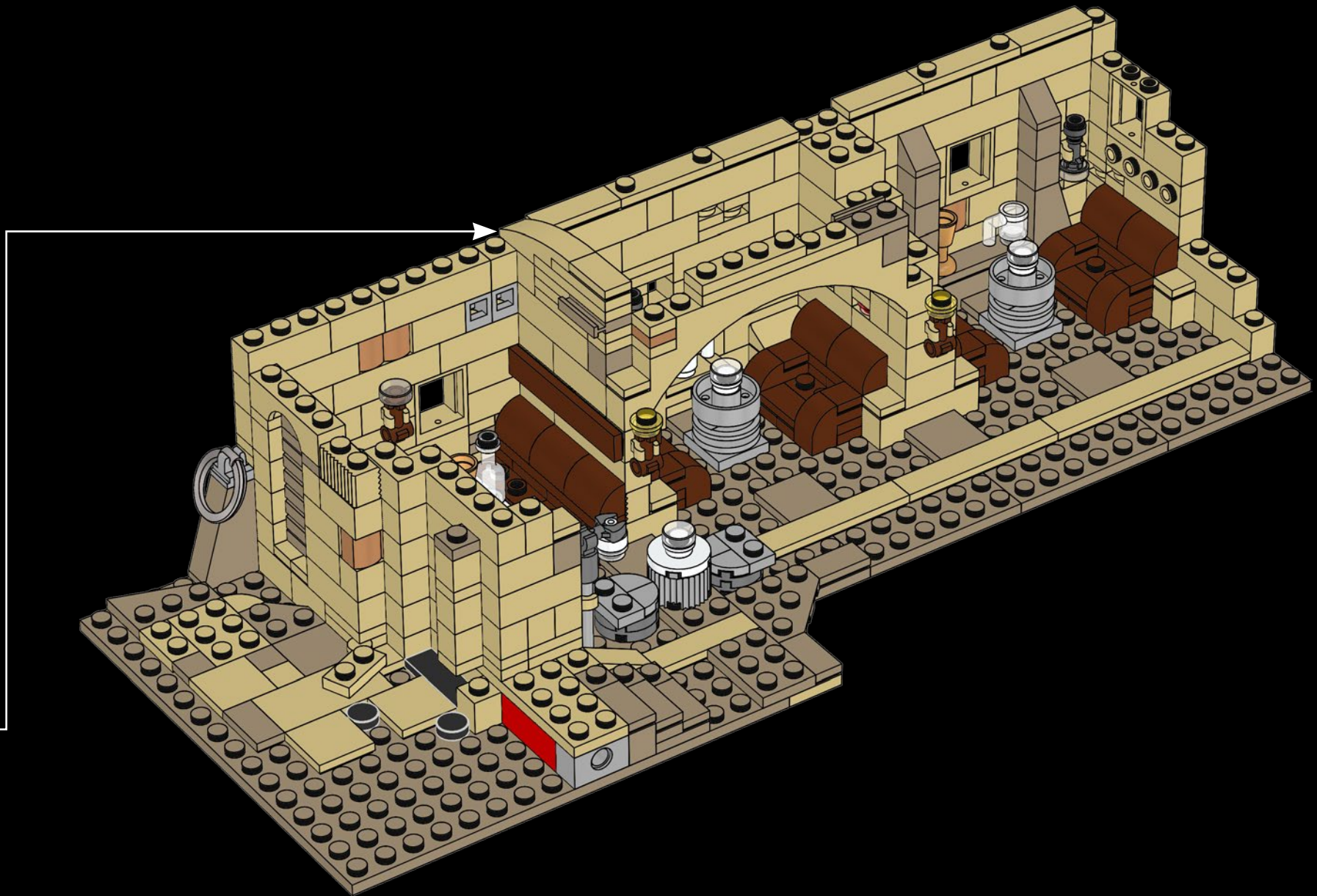

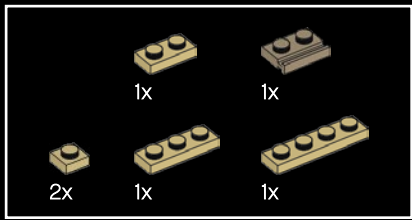

100

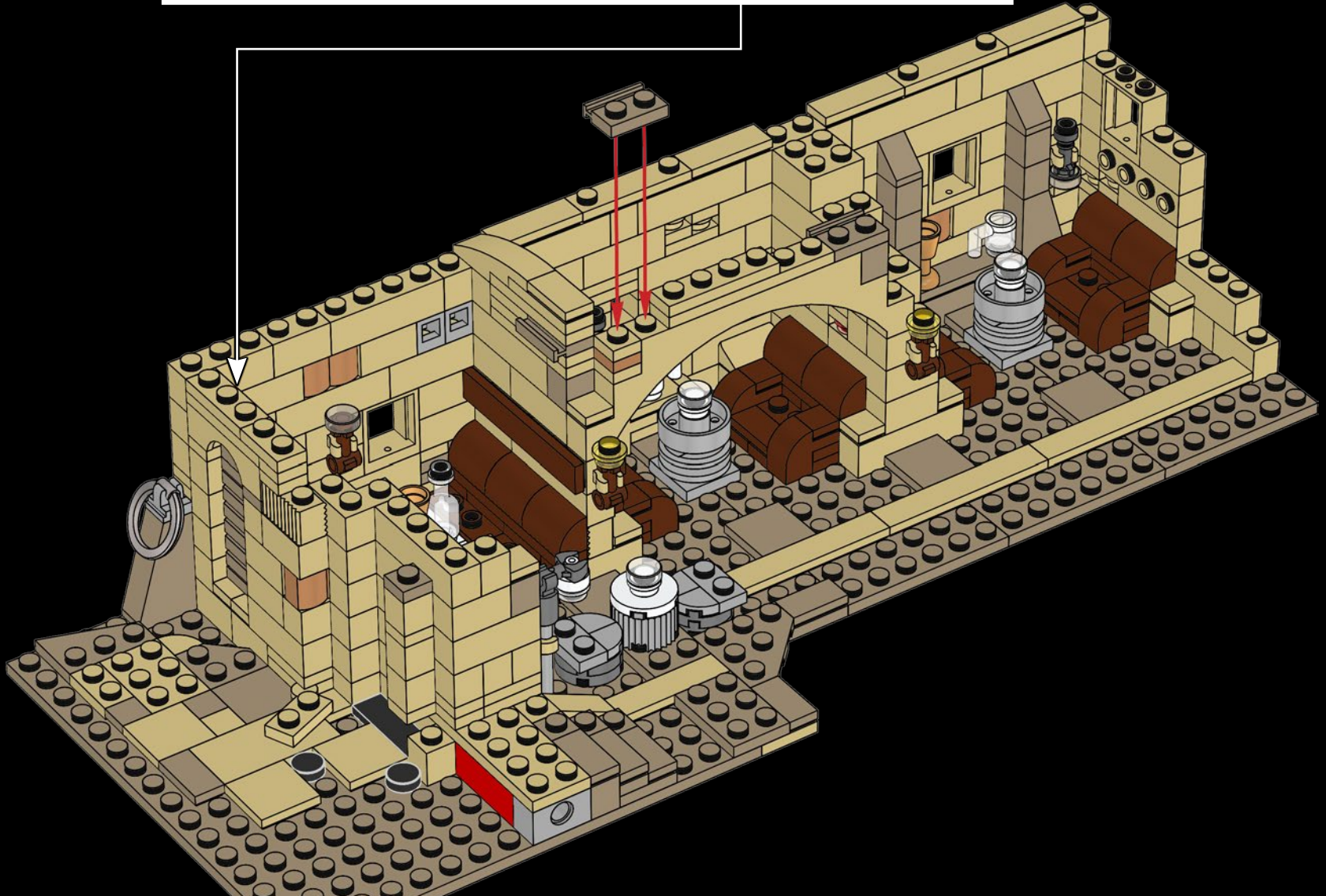
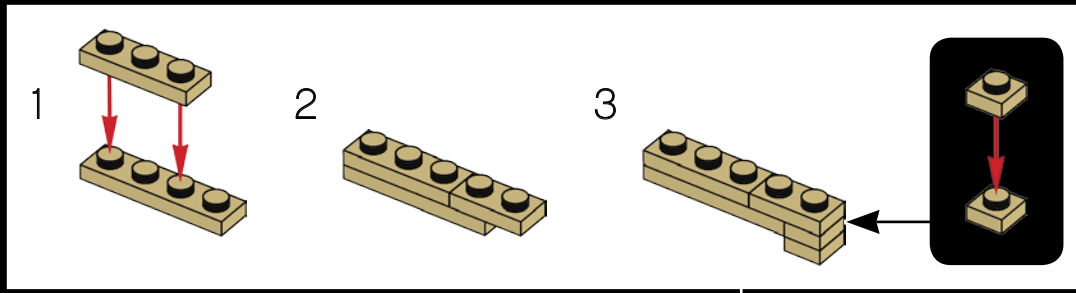

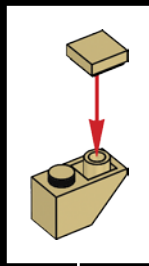
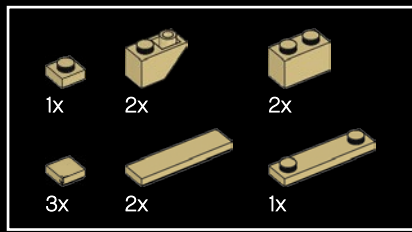

101

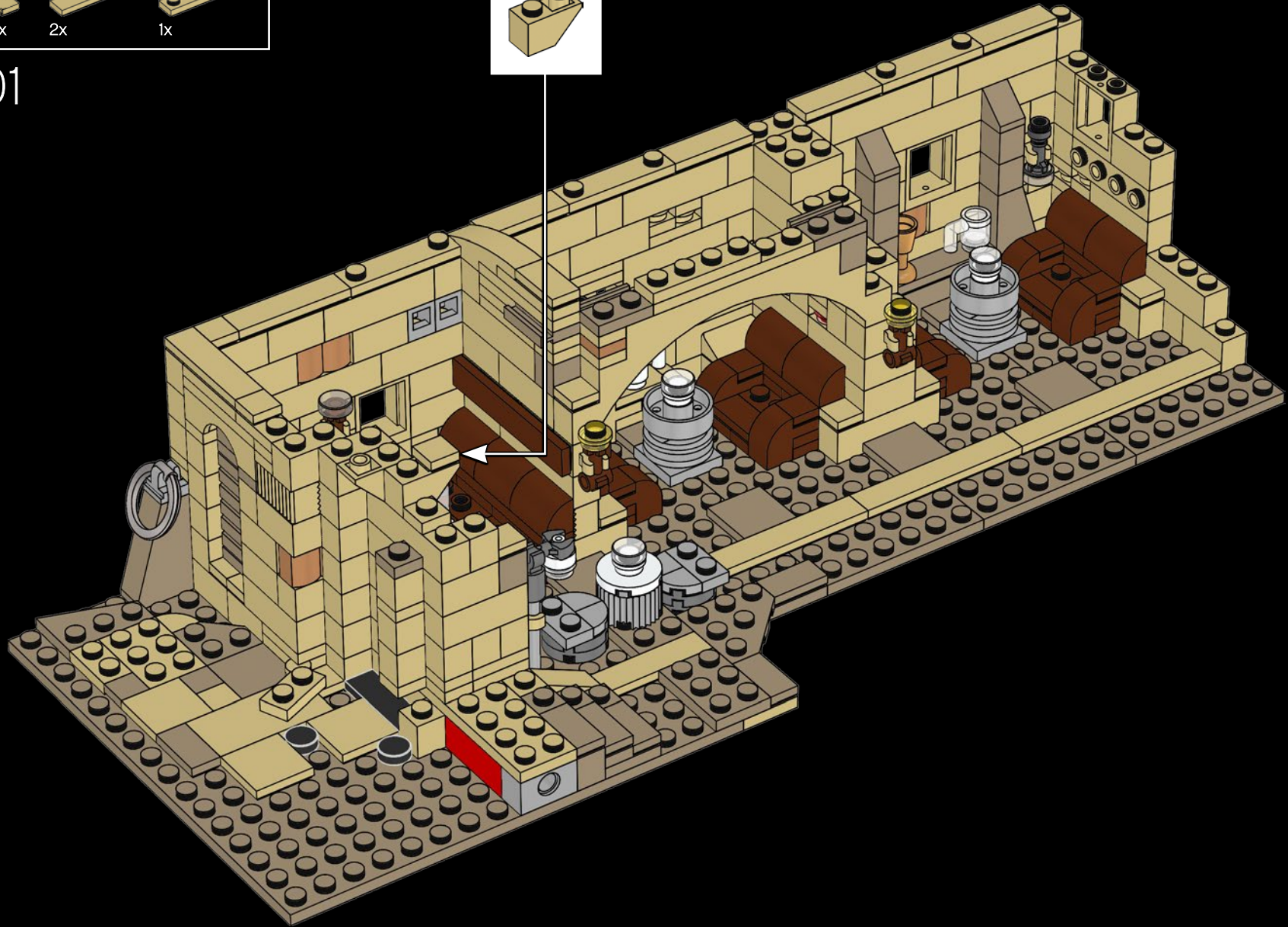



102

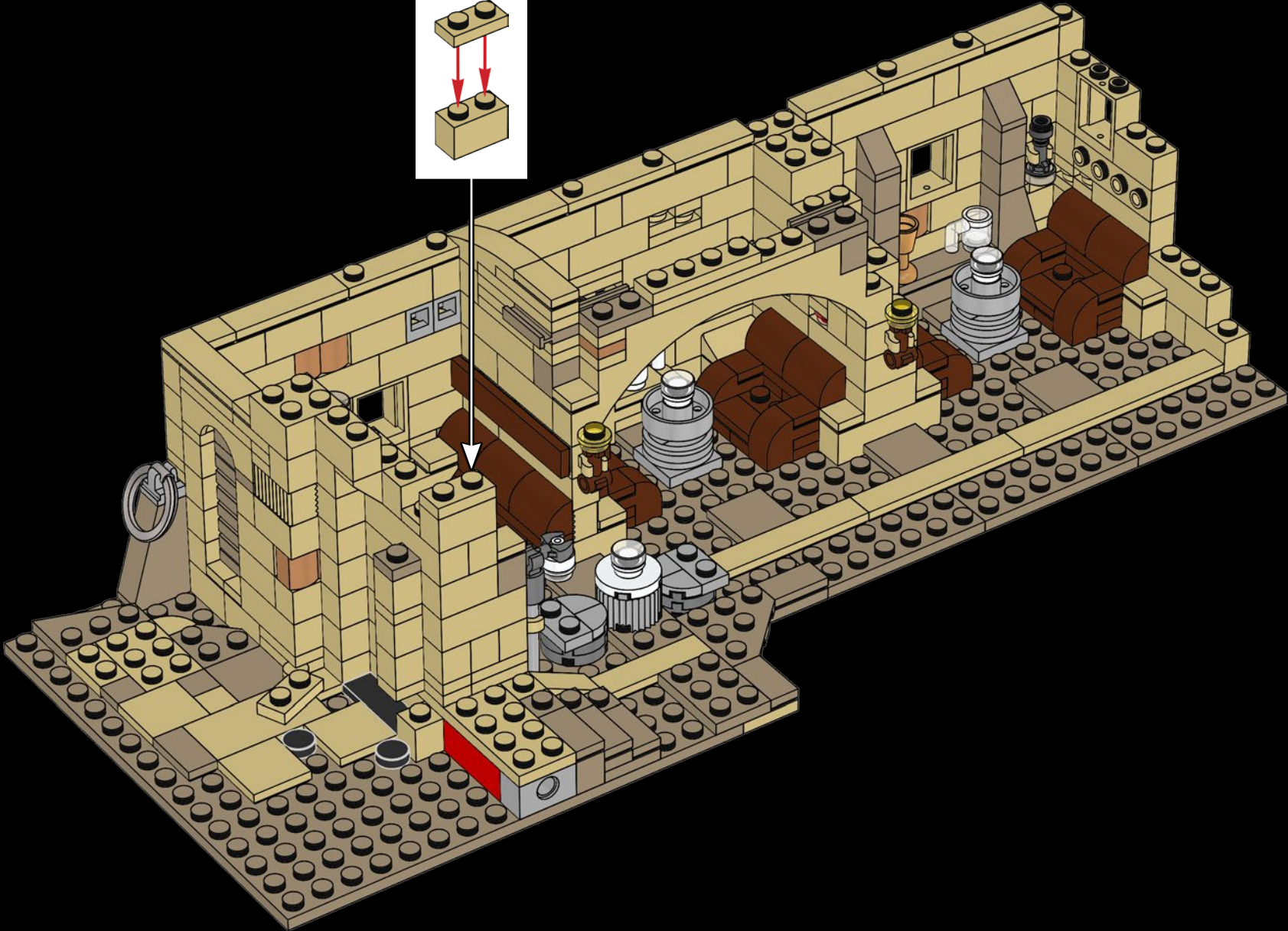
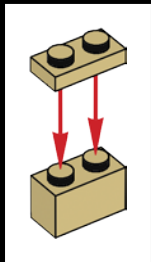

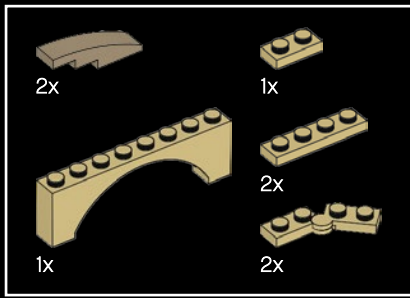

103

1

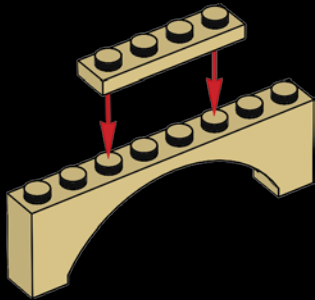

2

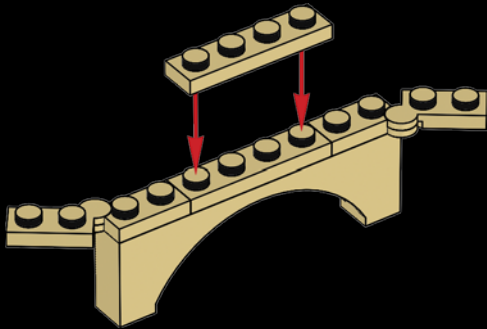

3

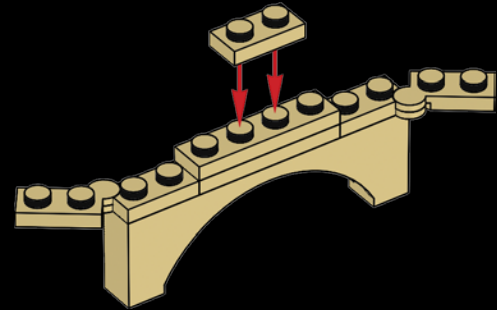

4

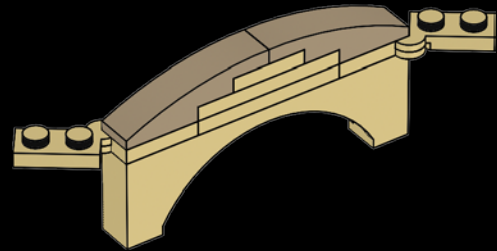

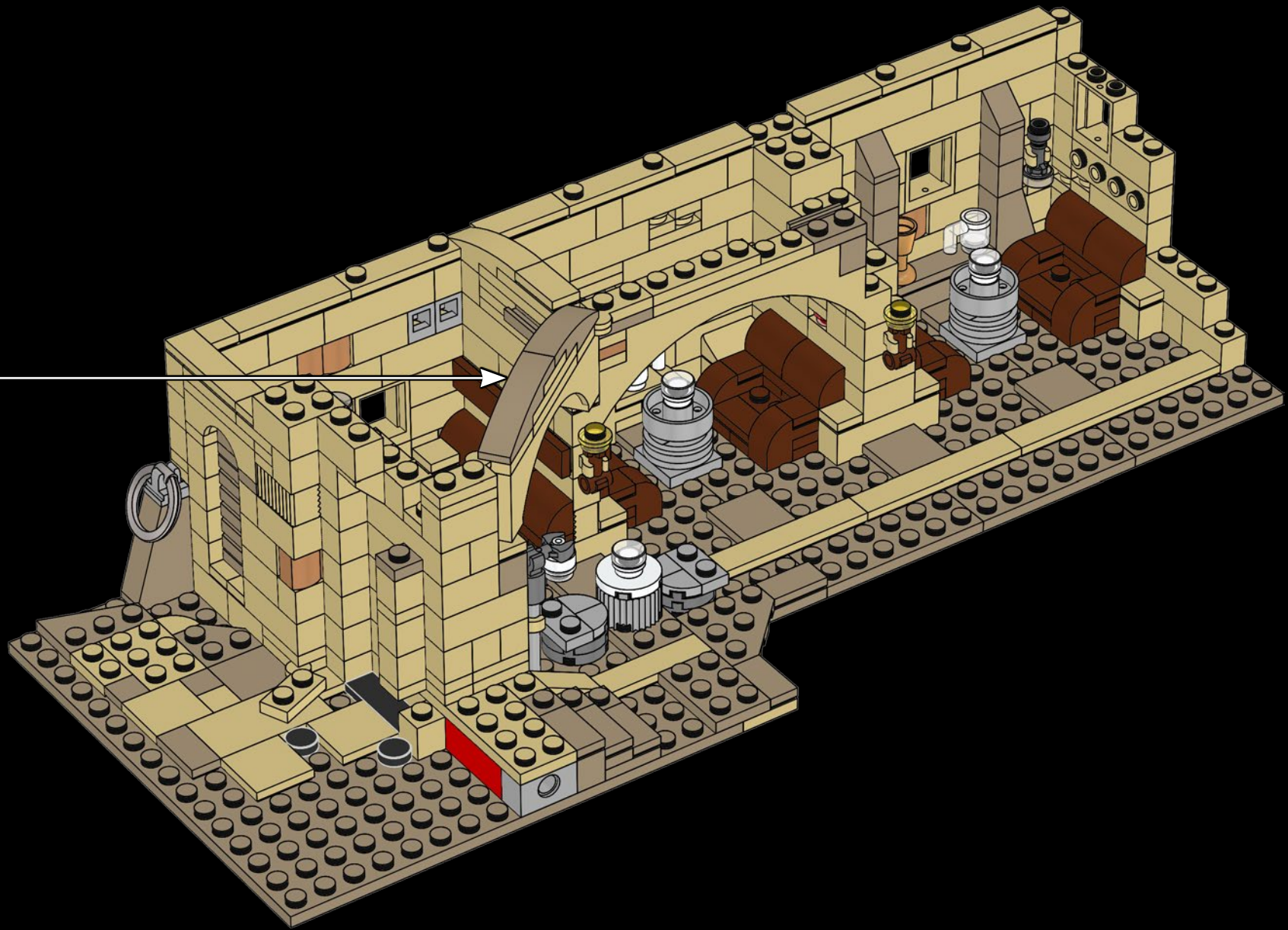

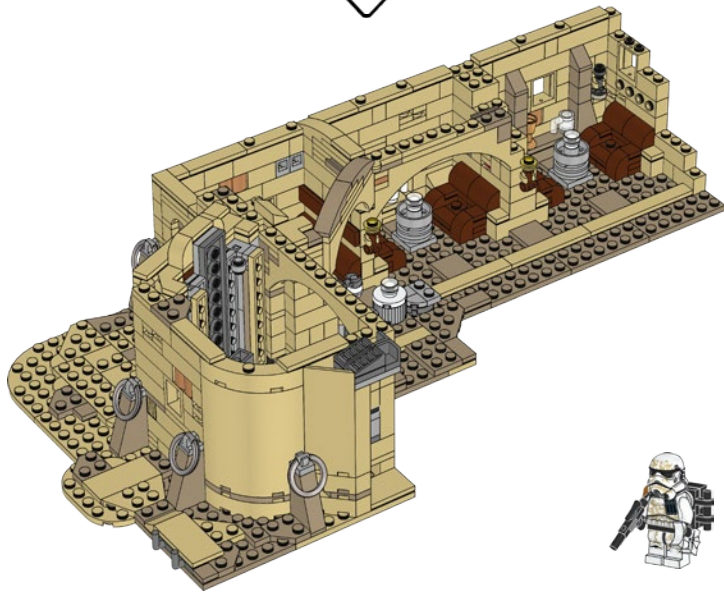
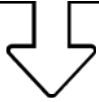
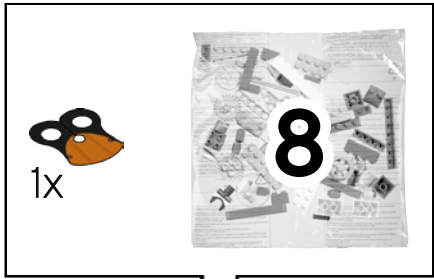

1

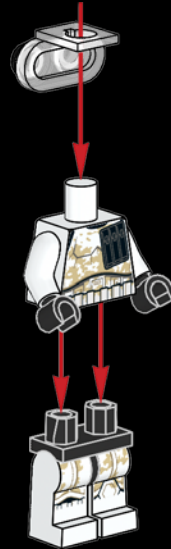

2



“Sandtroopers” is a nickname for Stormtroopers operating in desert worlds. Their armor looks like Stormtrooper outfits at first glance, but it's augmented with cooling units, a helmet sand filter, and a survival backpack with extra rations and water. In *Star Wars: A New Hope*, they ride the native Tatooine dewbacks through the desert in their search for the lost Death Star plans

« Sandtroopers » est un surnom que l'on donne aux Stormtroopers travaillant dans les mondes désertiques. À première vue, leur armure ressemble à celle des Stormtroopers, mais elle comprend des unités de refroidissement, un casque à filtre anti-sable et un sac à dos de survie contenant des rations supplémentaires et de l'eau. Dans *Star Wars : Un Nouvel Espoir*, ils chevauchent des dewbacks, espèce indigène de Tatooine, à travers le désert afin de retrouver les plans perdus de l'Étoile de la Mort.

Los Troopers de las arenas son soldados expertos en el desarrollo de operaciones en mundos desérticos. A primera vista, su armadura es similar a la de un Stormtrooper; sin embargo, cuenta además con unidades de refrigeración, un filtro de arena en el casco y una mochila de supervivencia con raciones extra y agua. En *Star Wars: Una Nueva Esperanza*, cabalgan por el desierto a espaldas de Dewbacks, criaturas nativas de Tatooine, en busca de los planos perdidos de la Estrella de la Muerte.

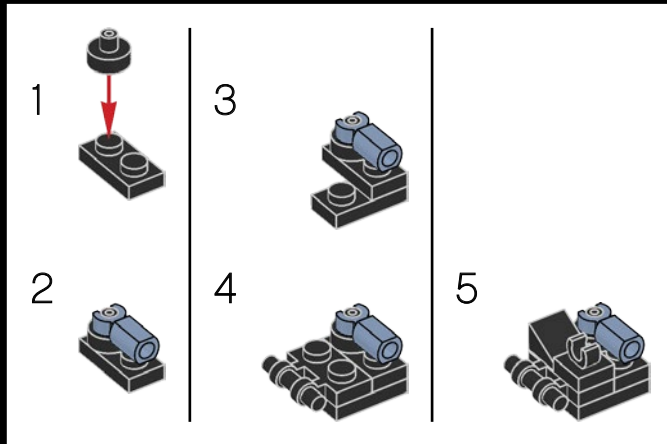

3

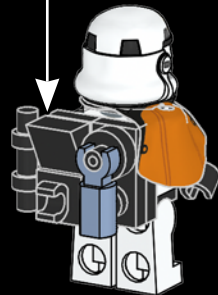

4

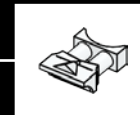

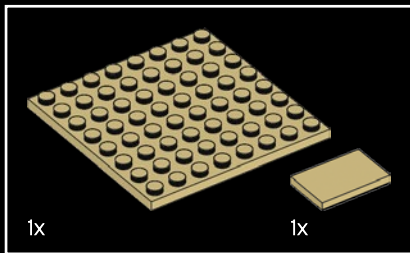
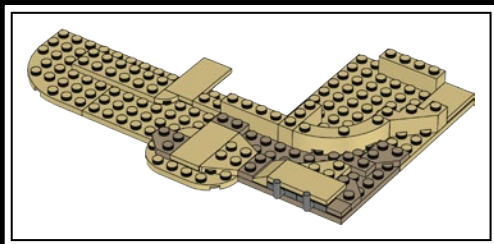

104

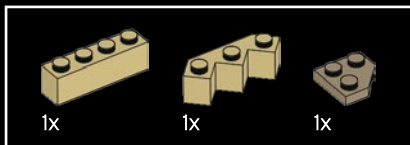
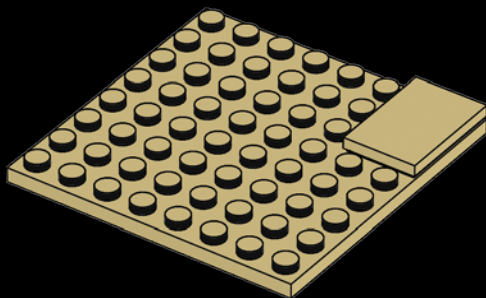

105

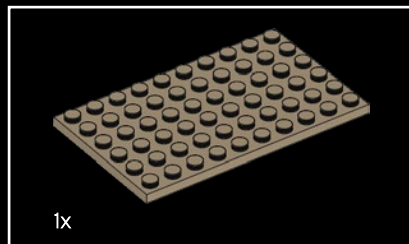
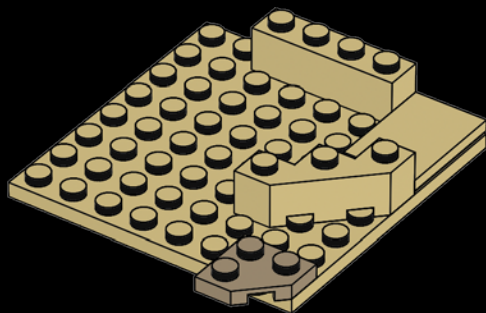

106

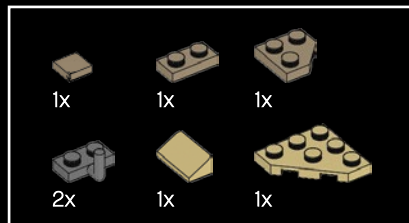
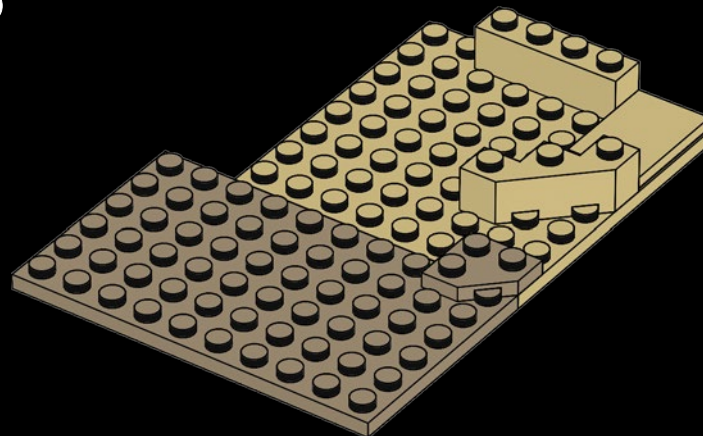

107

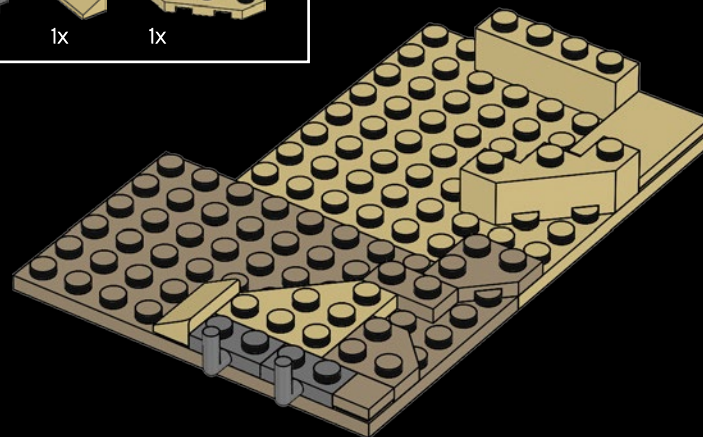

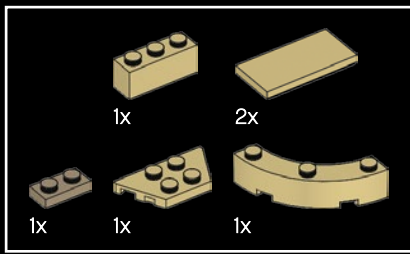

108

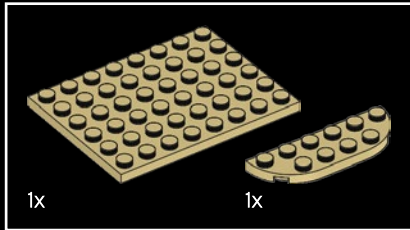
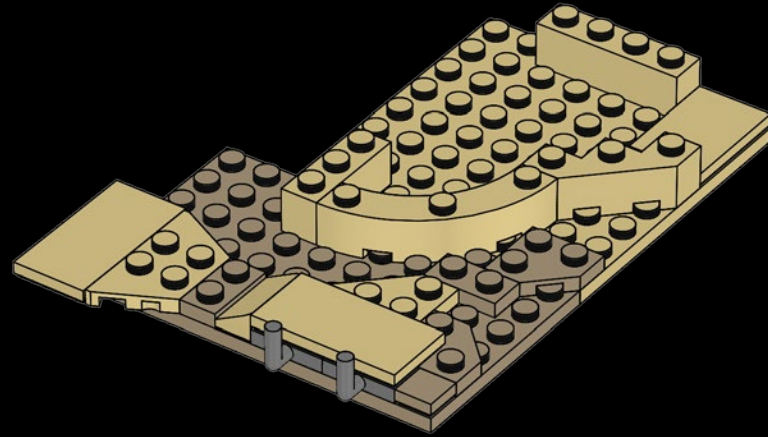

109

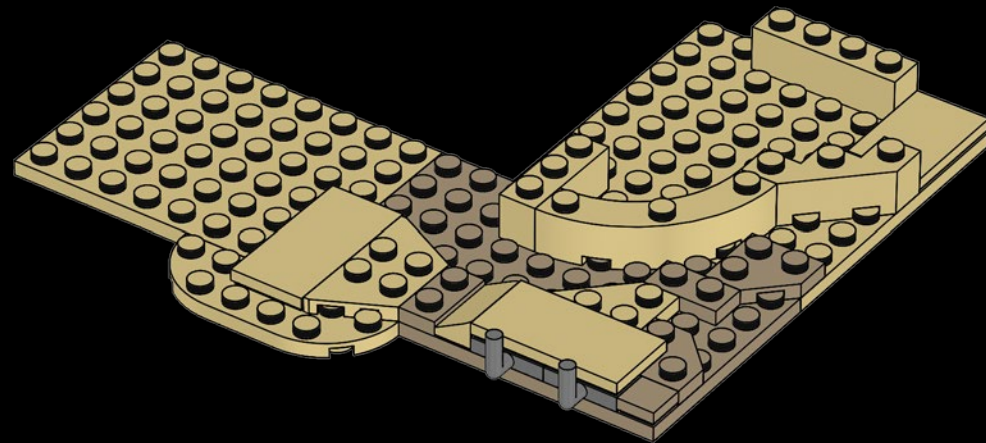

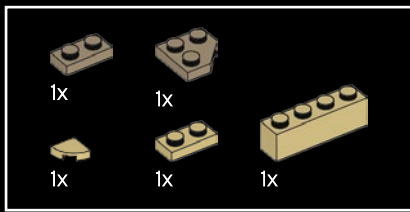

110

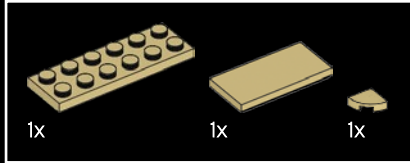
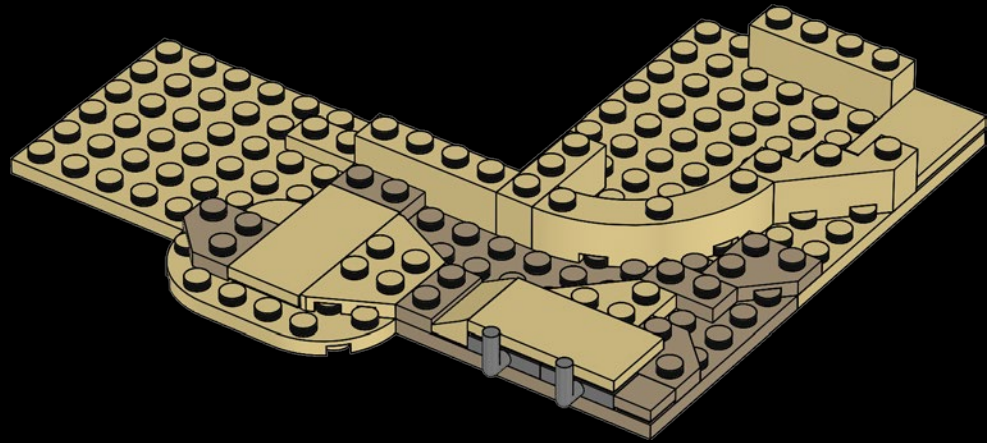

111

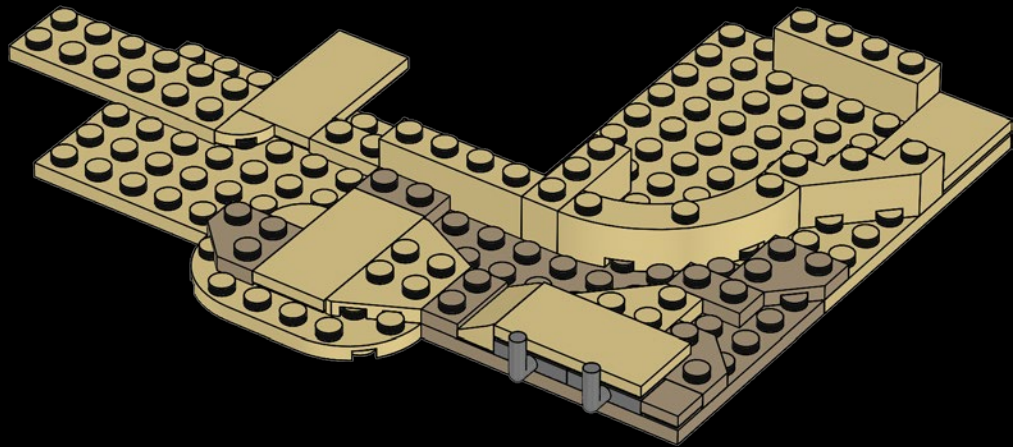

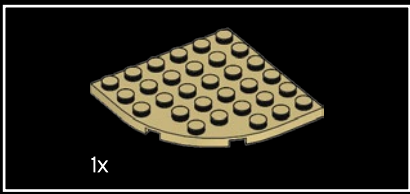

112

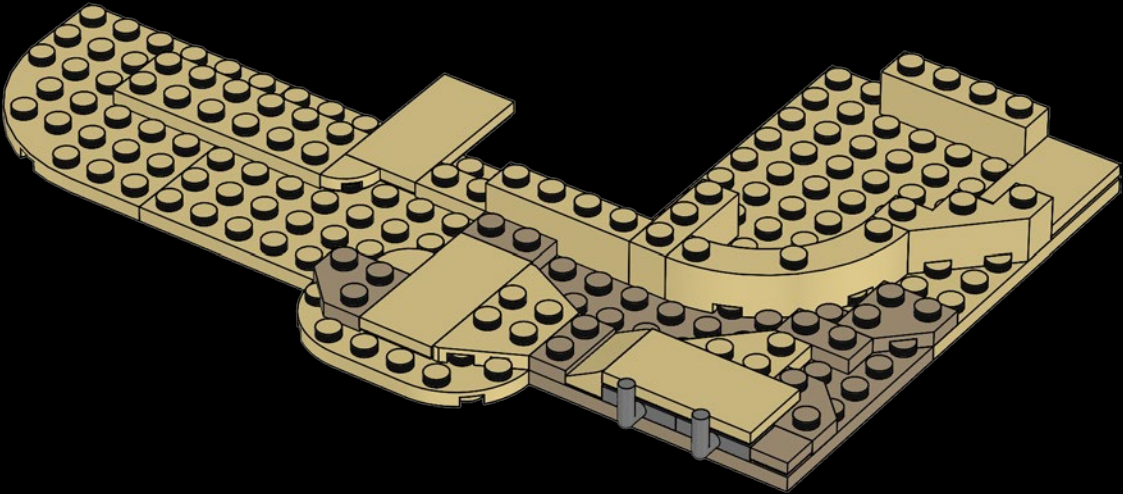

113

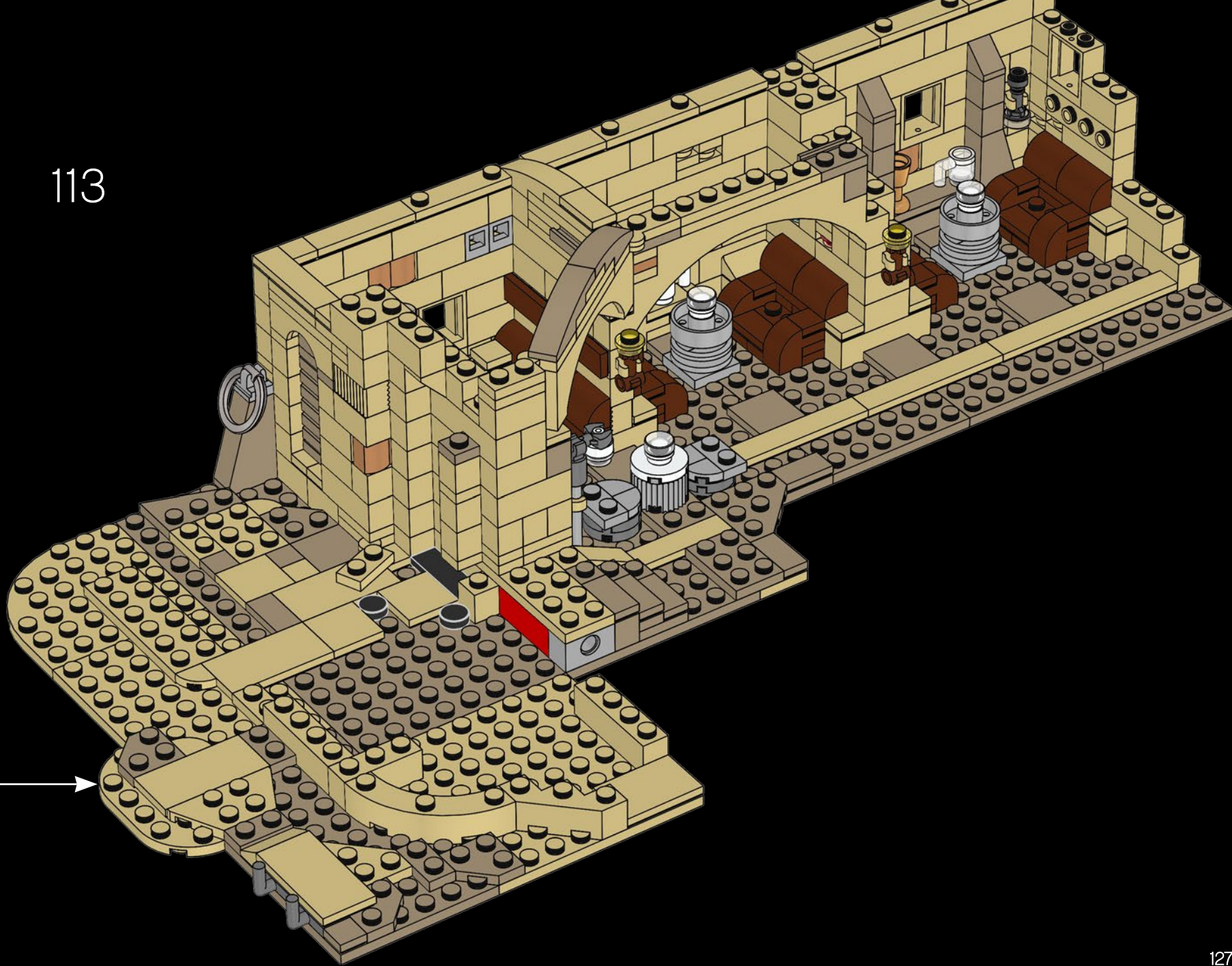

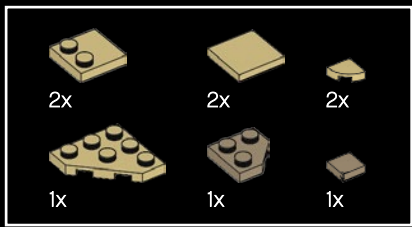

114



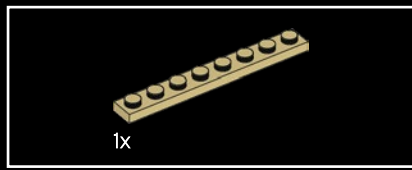

115

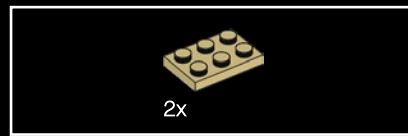
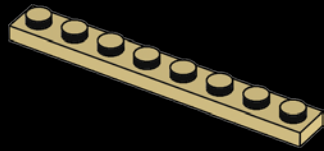

117

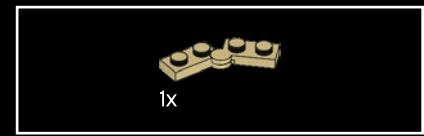
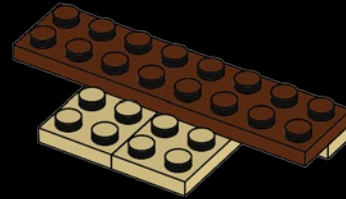

119

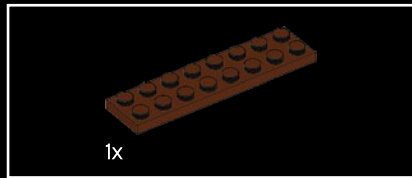
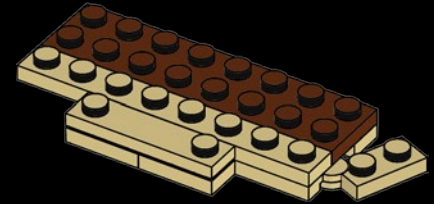

116

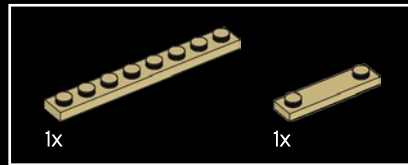
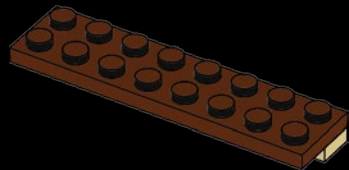

118

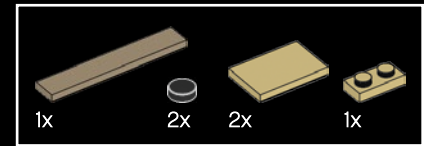
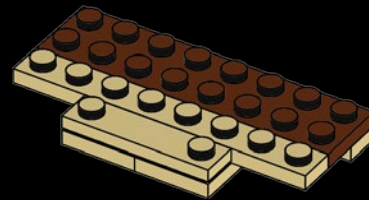

120

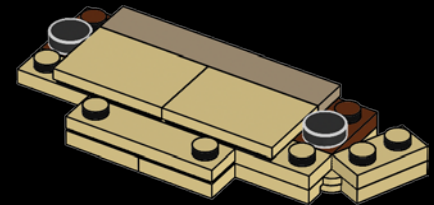

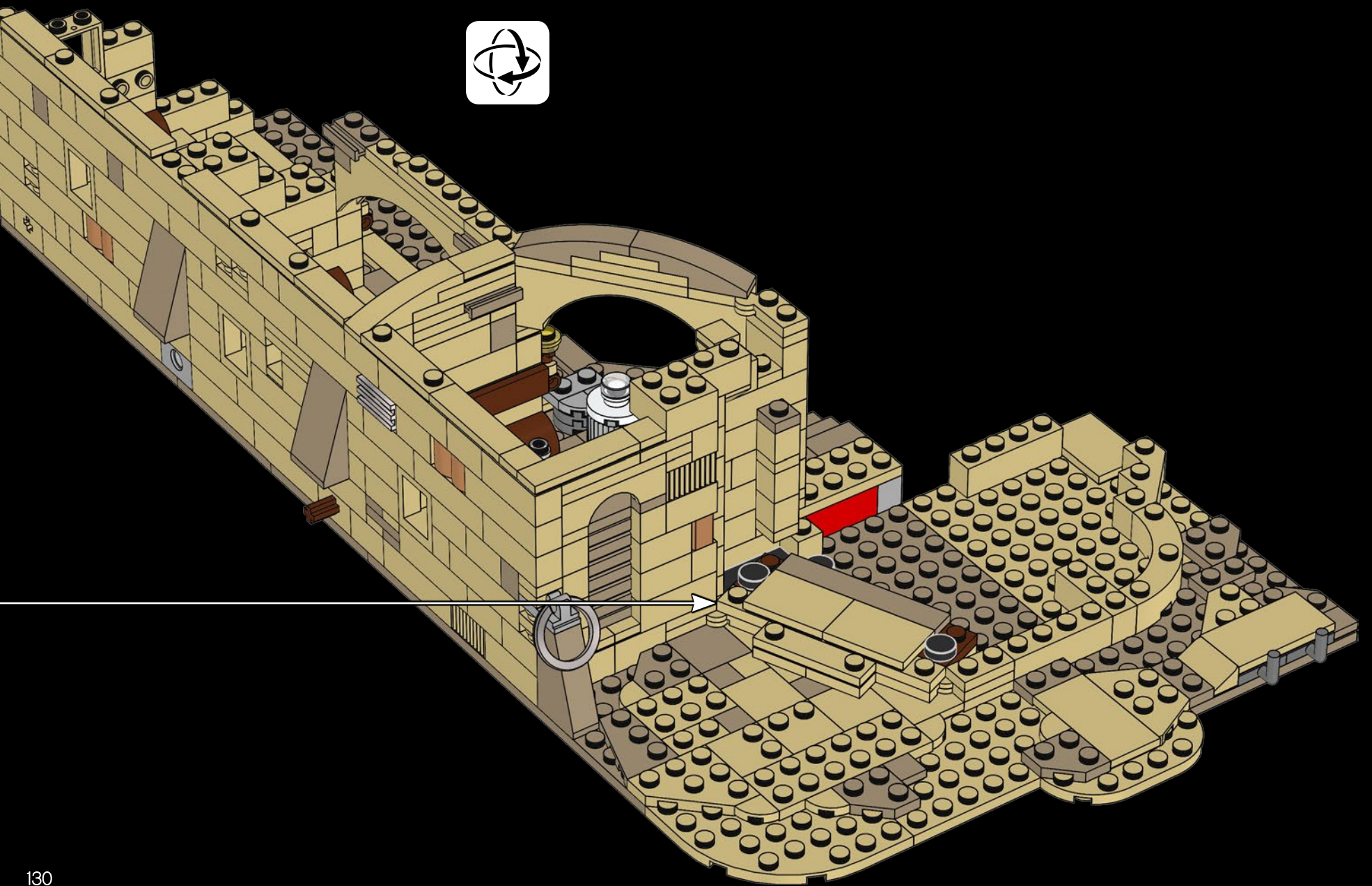

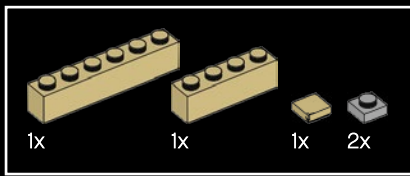

122

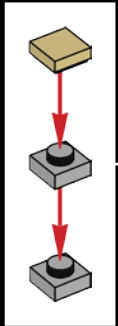

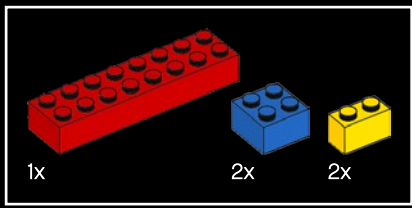

123

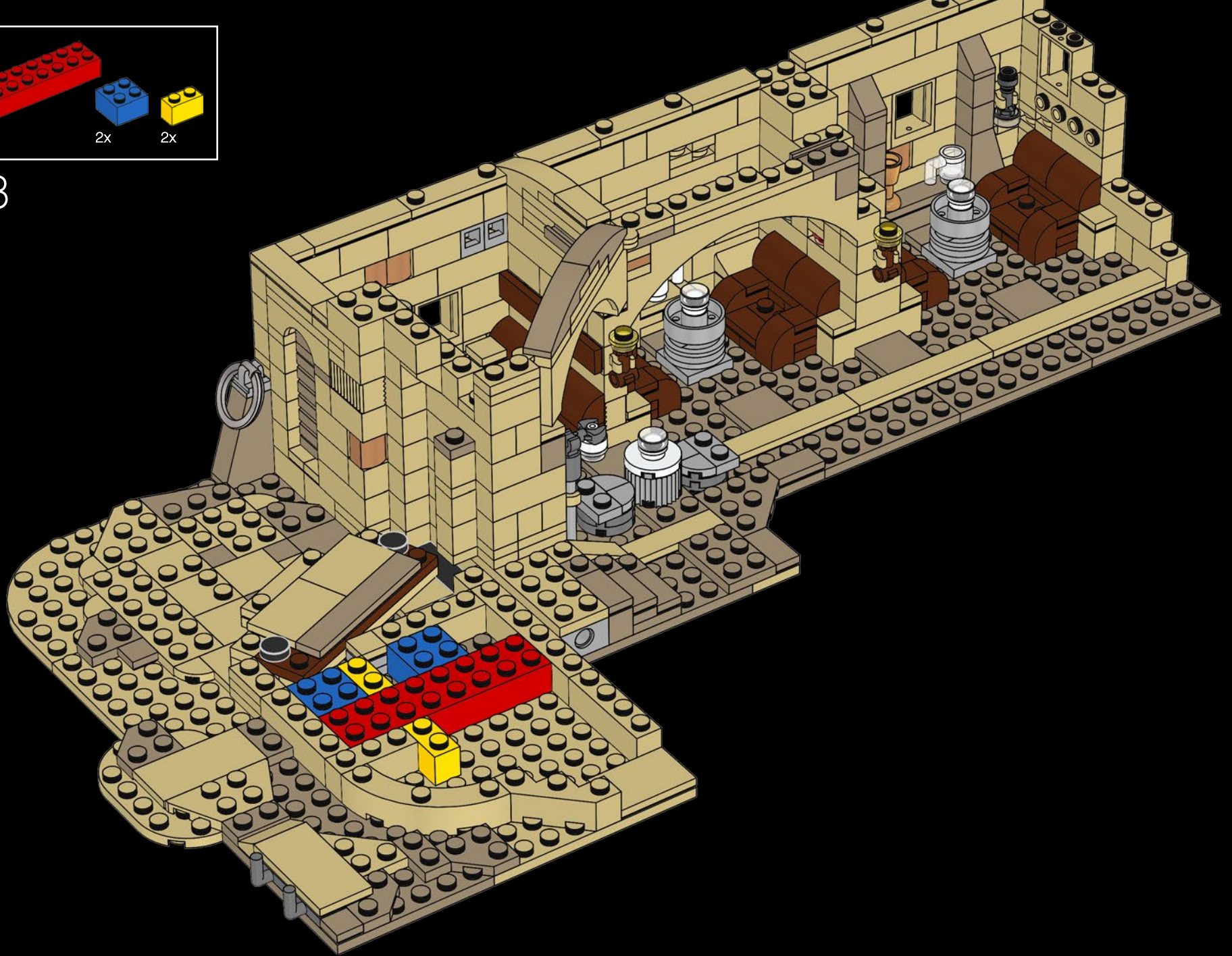

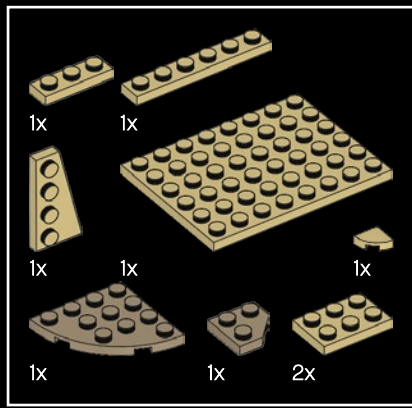

124

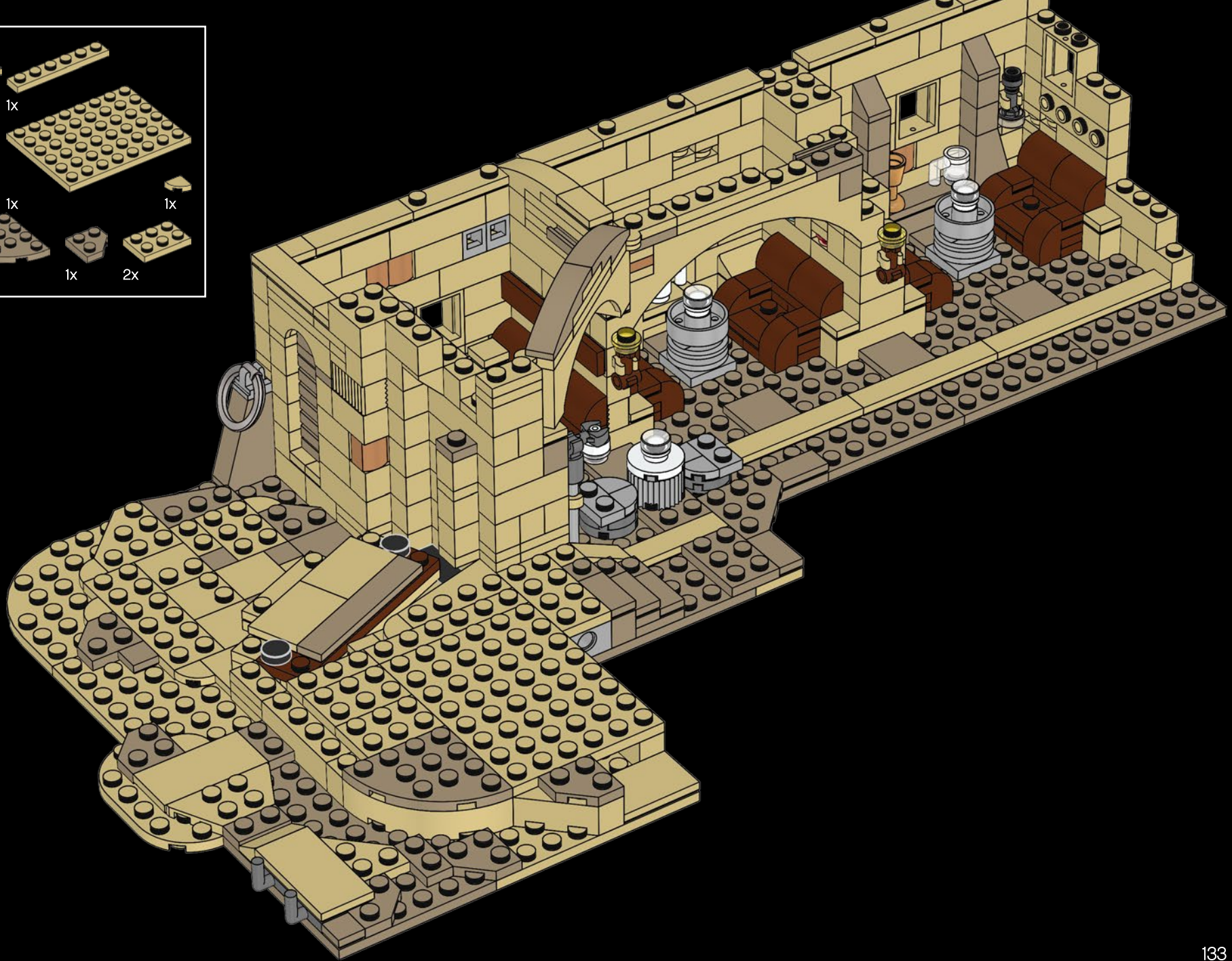

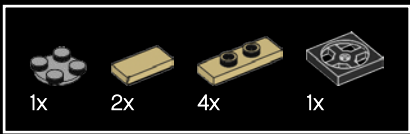

125

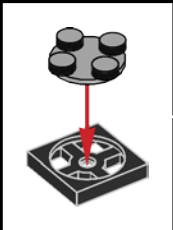



126

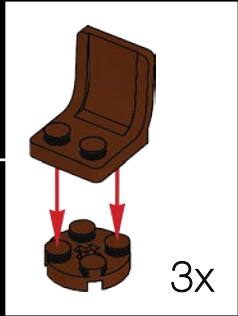
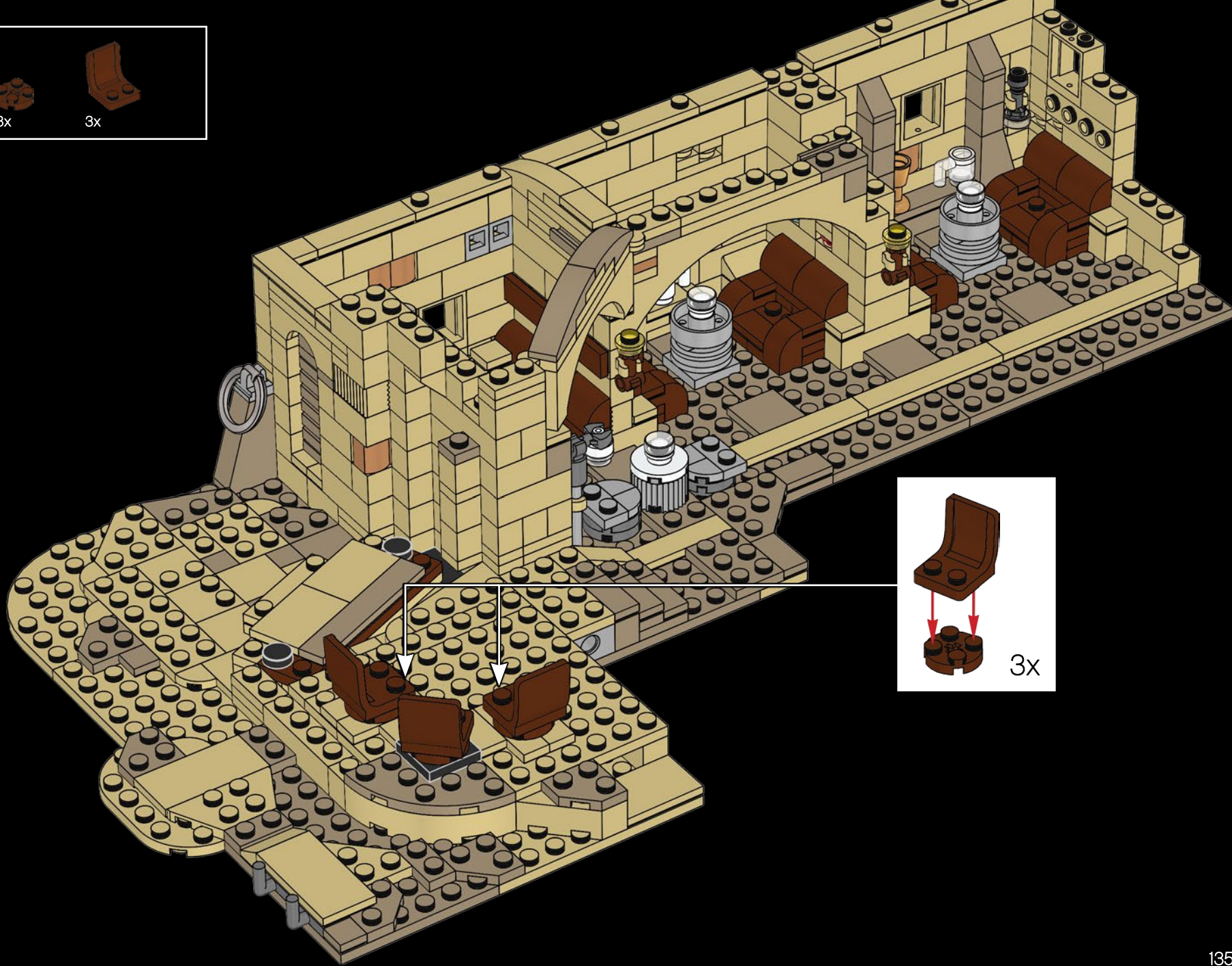

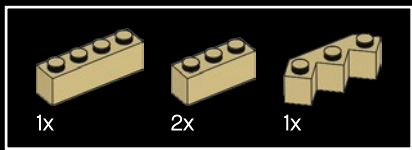

127



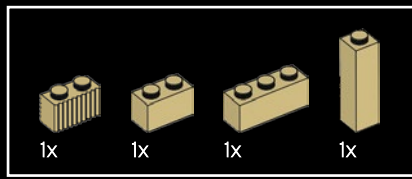

128



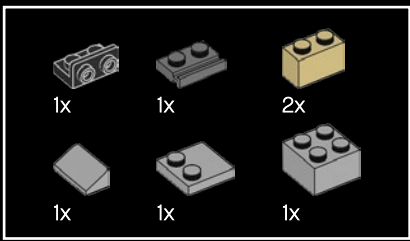

129

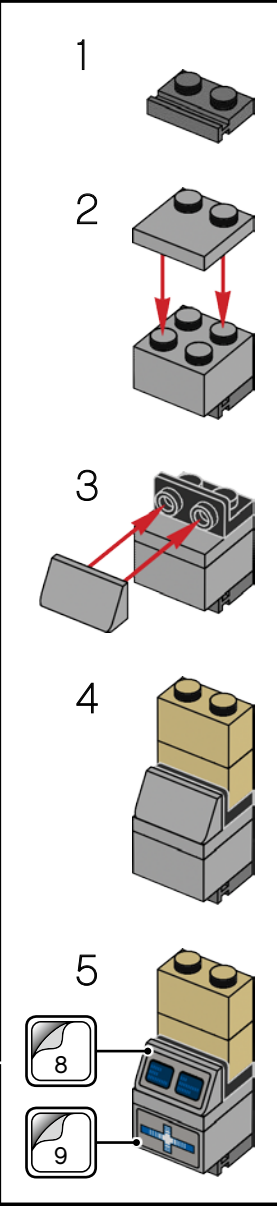
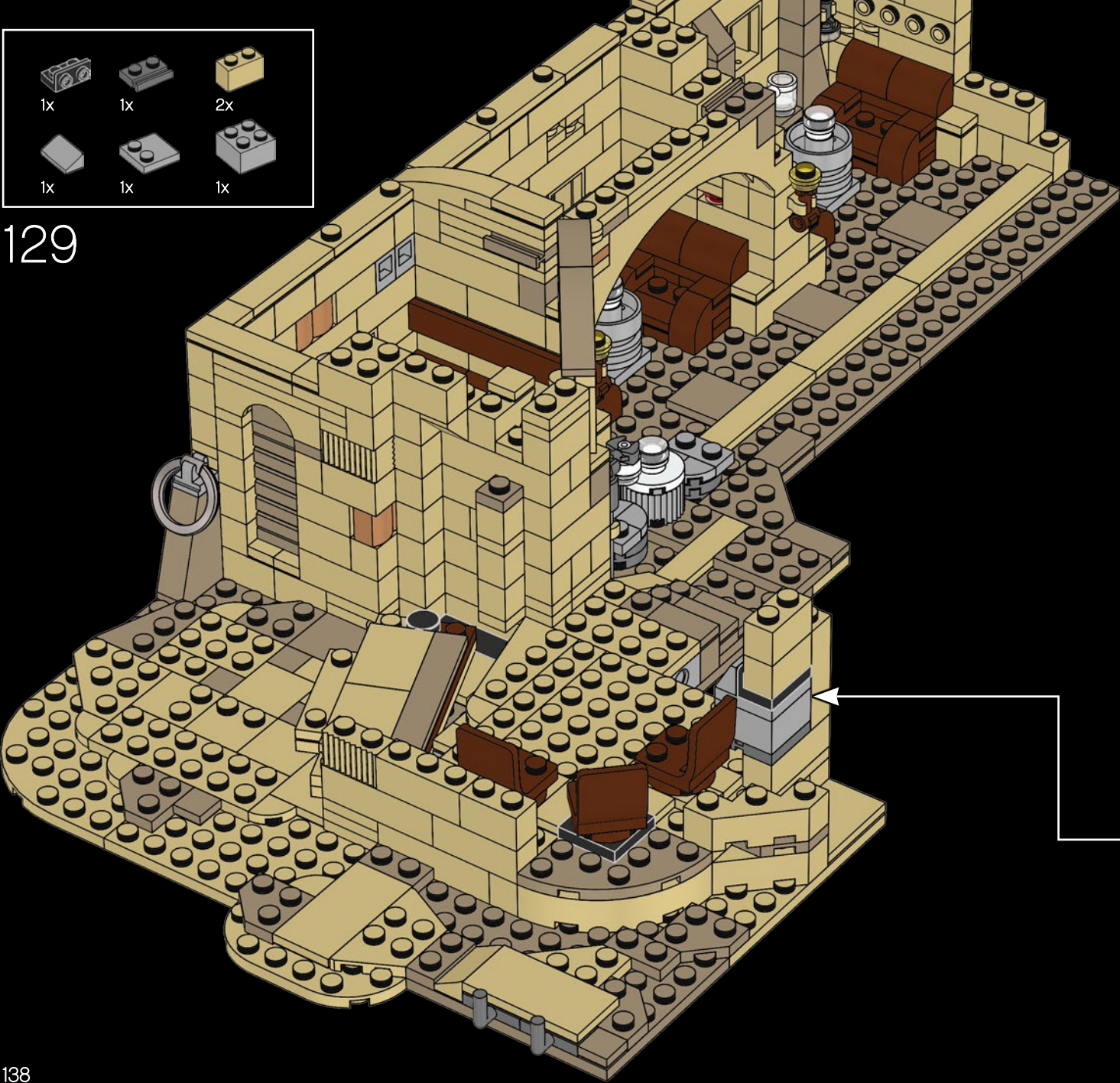

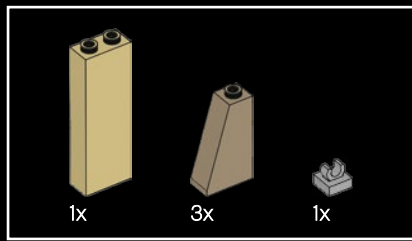

130

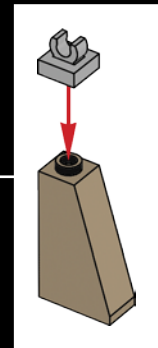
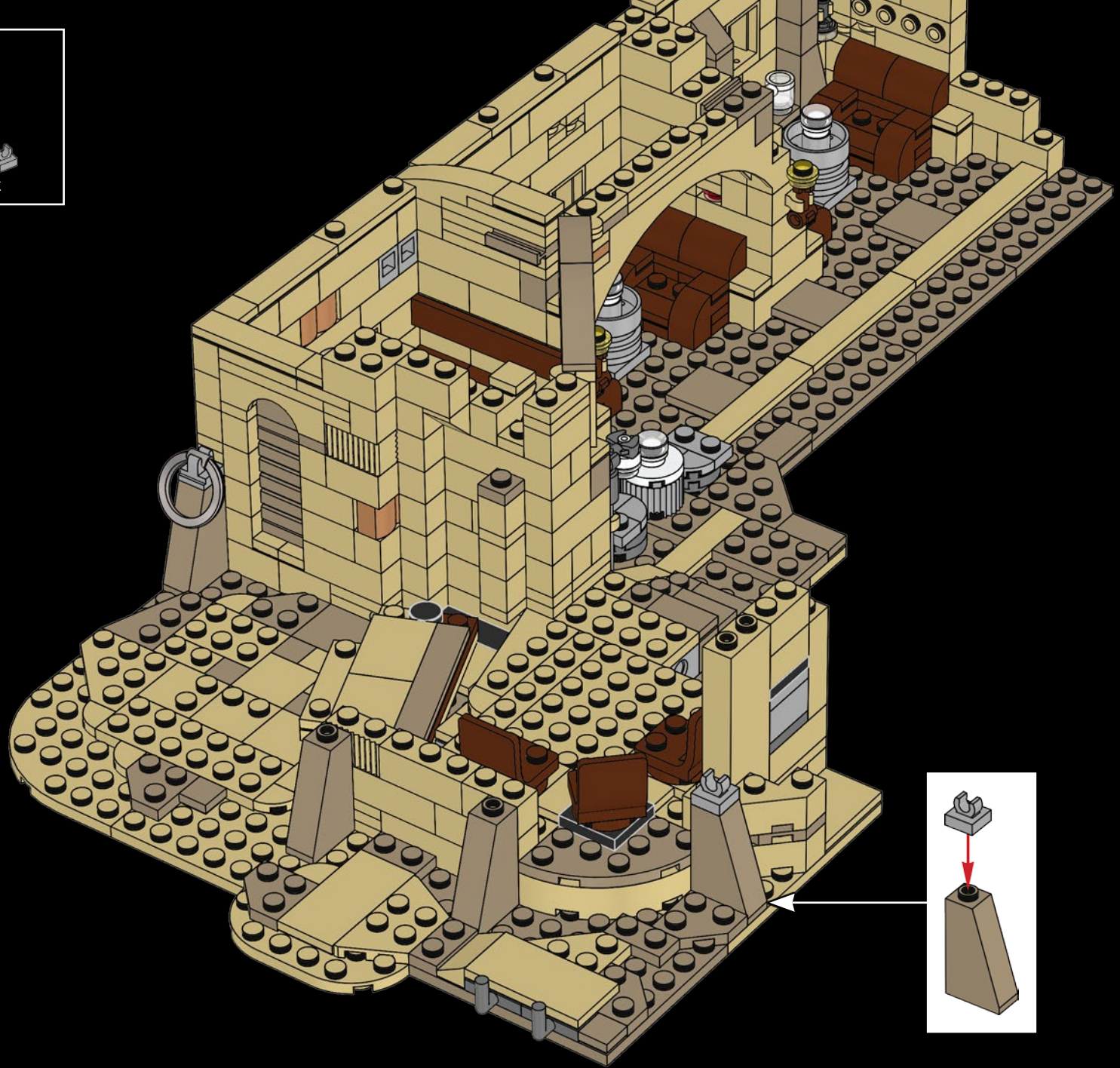

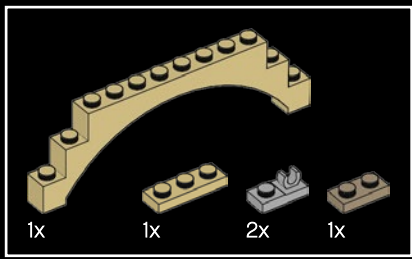

131



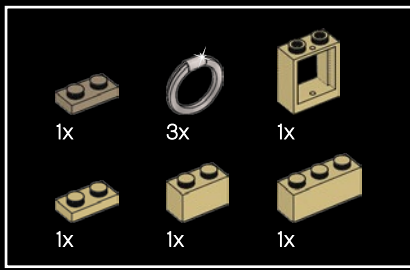

132

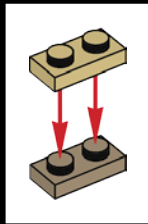

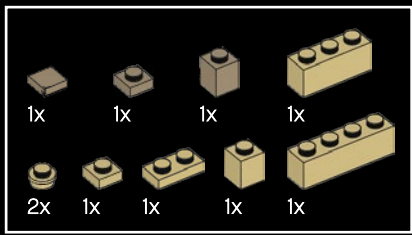

133

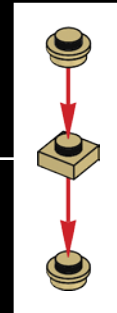
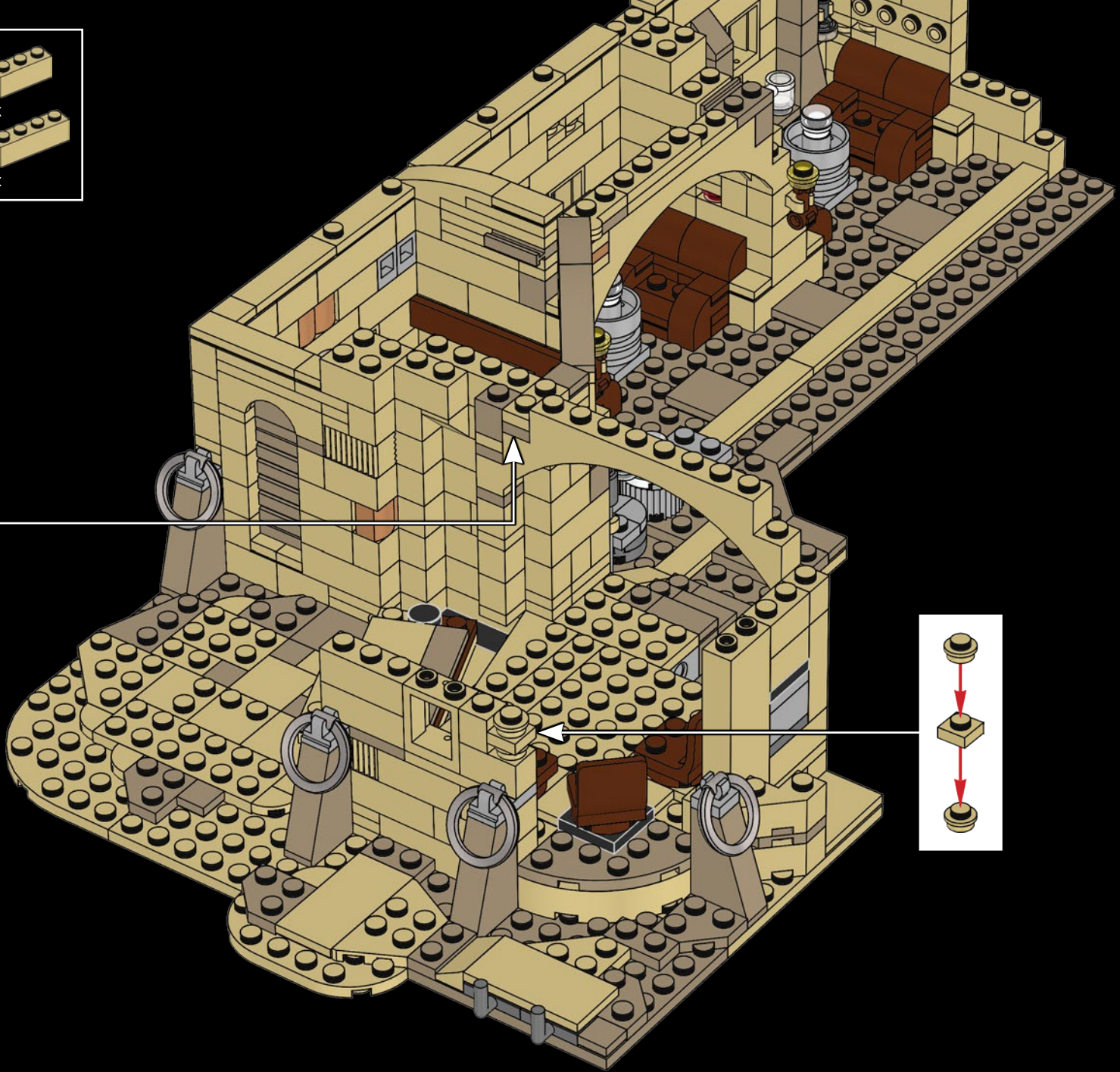
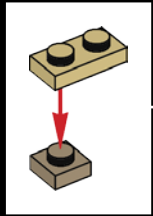

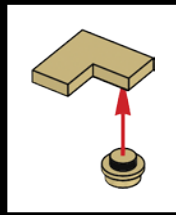
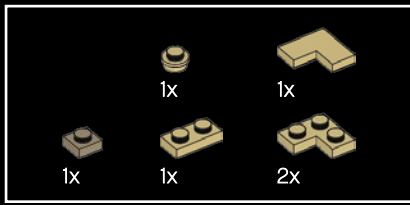

134

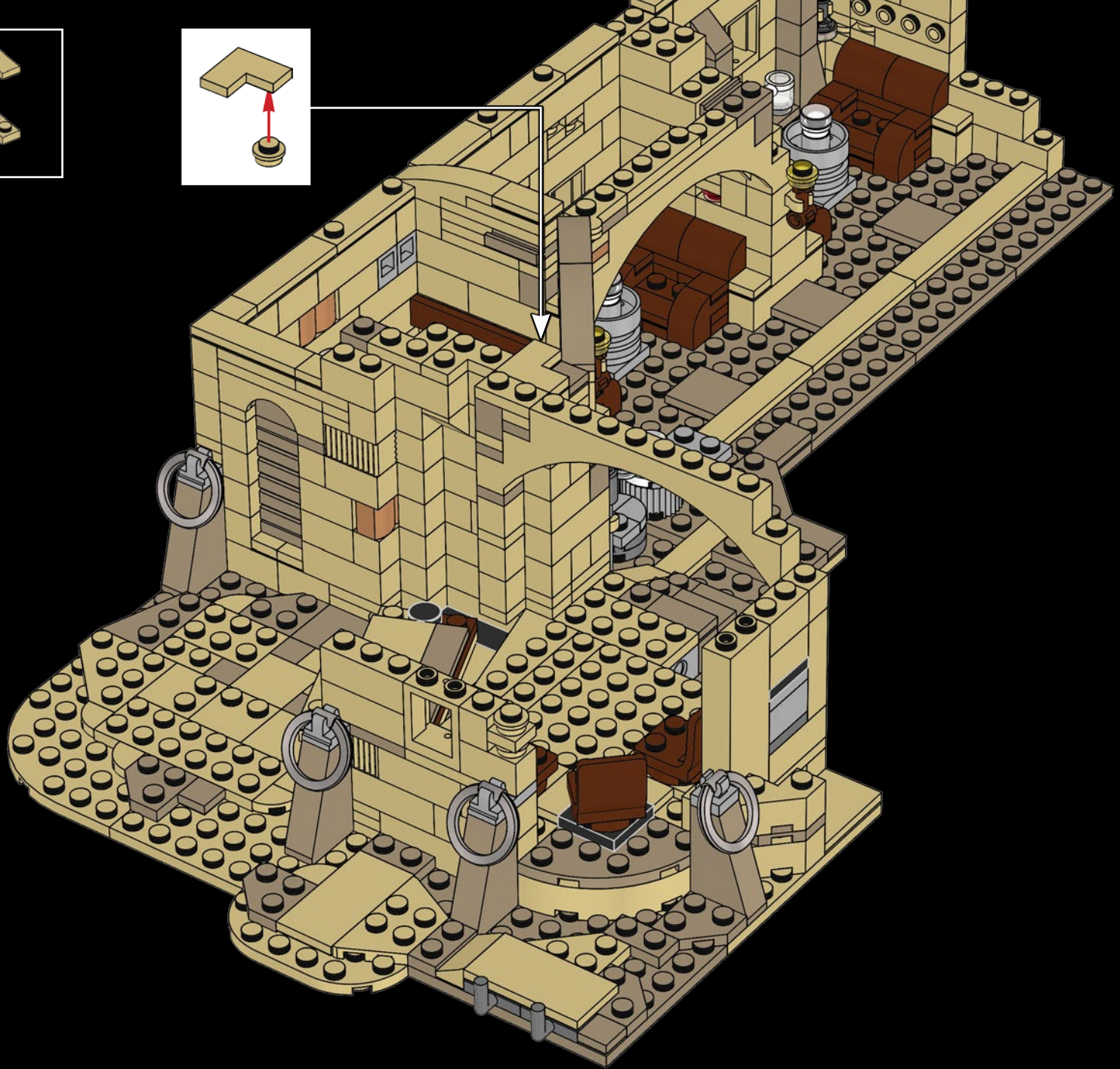

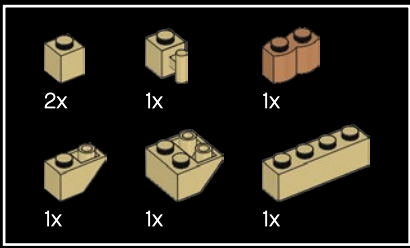

135

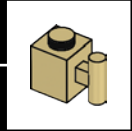
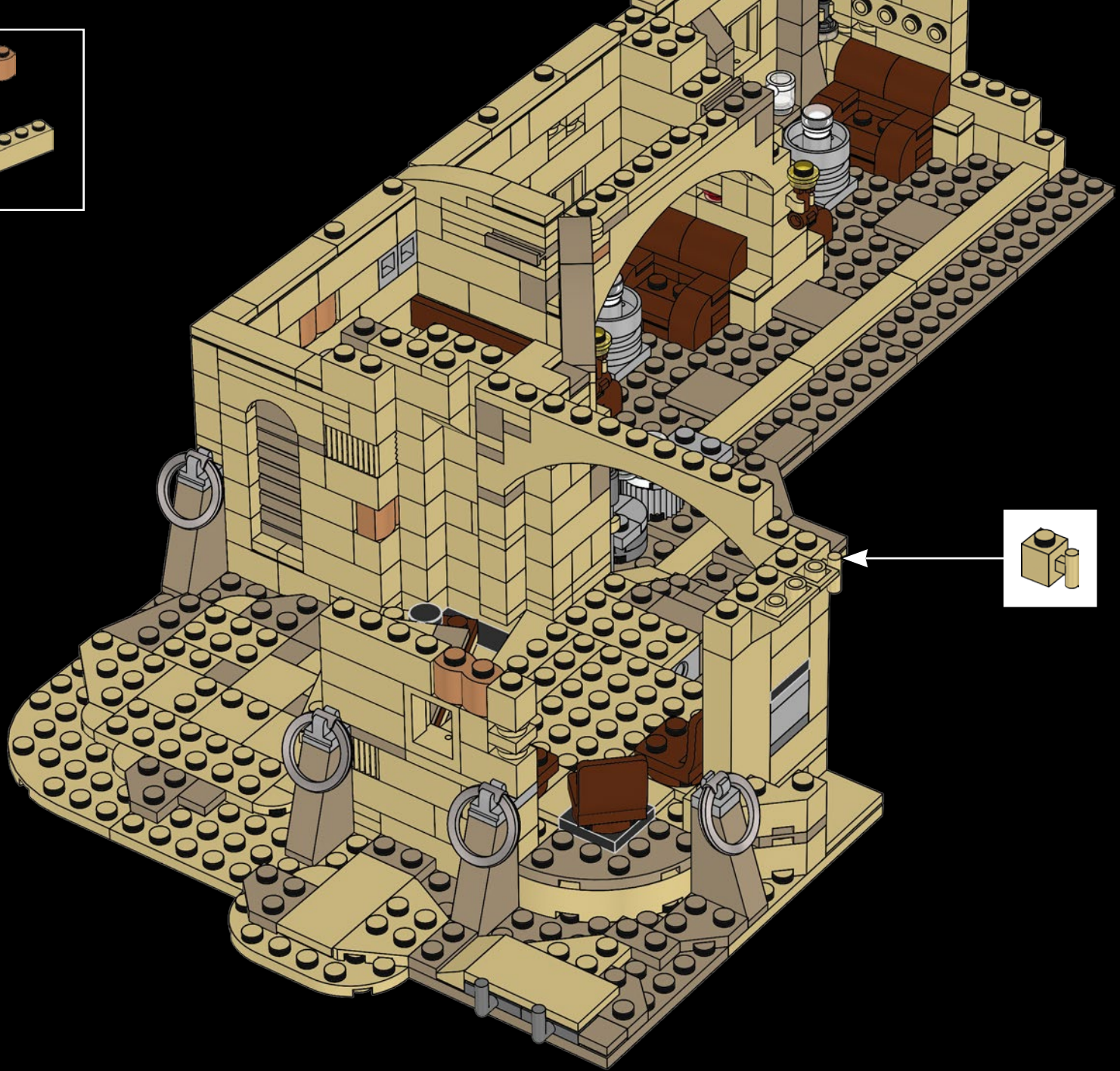

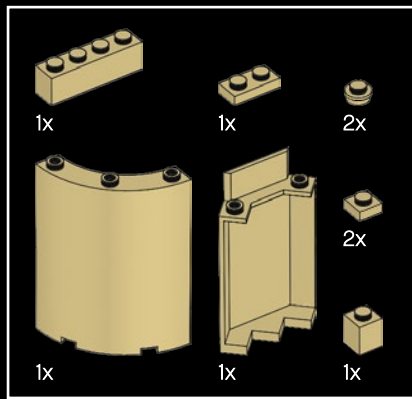

136

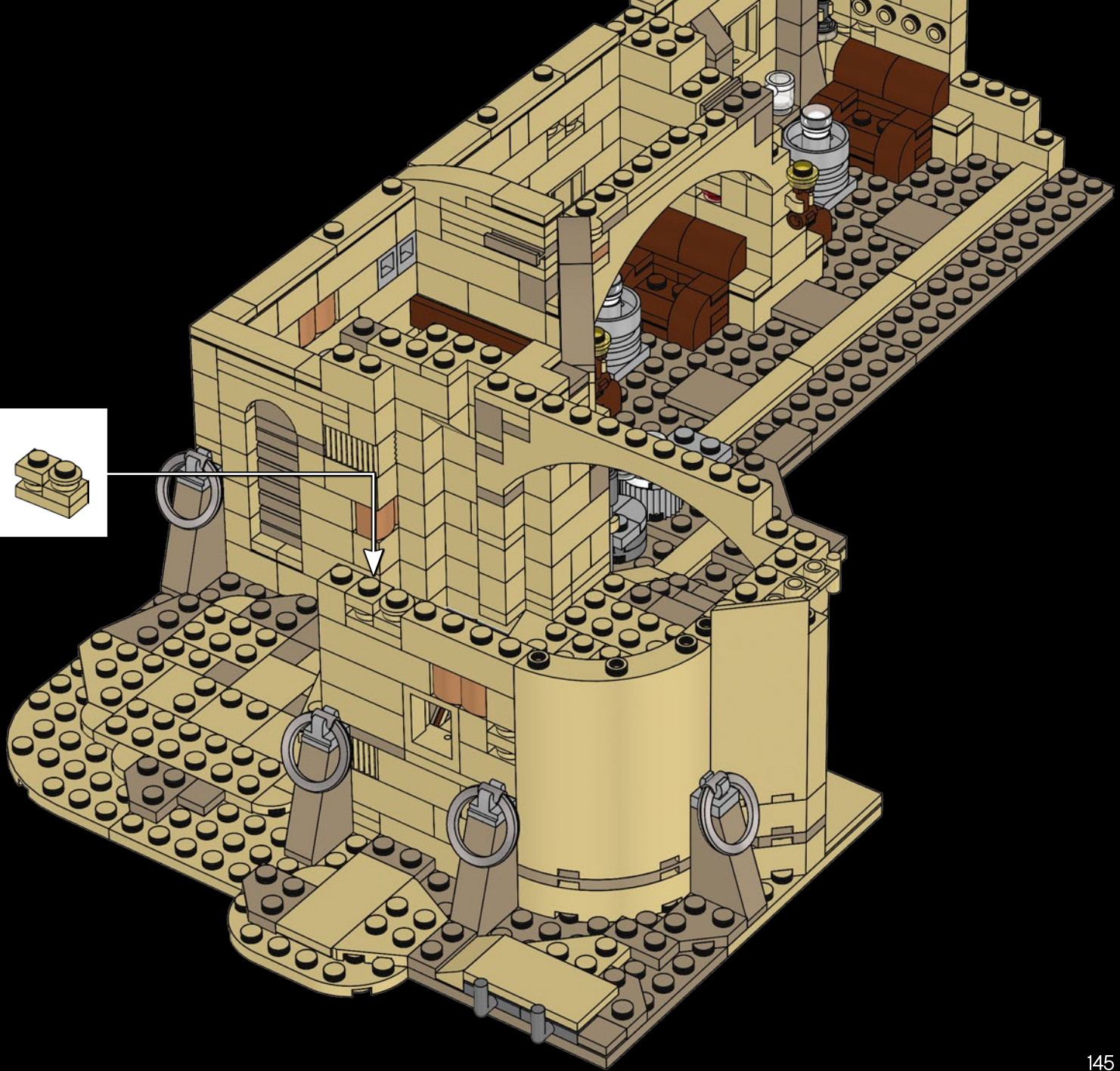
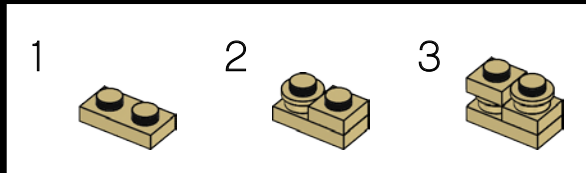

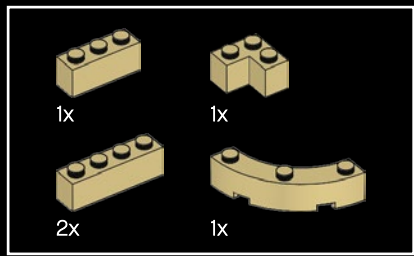

137

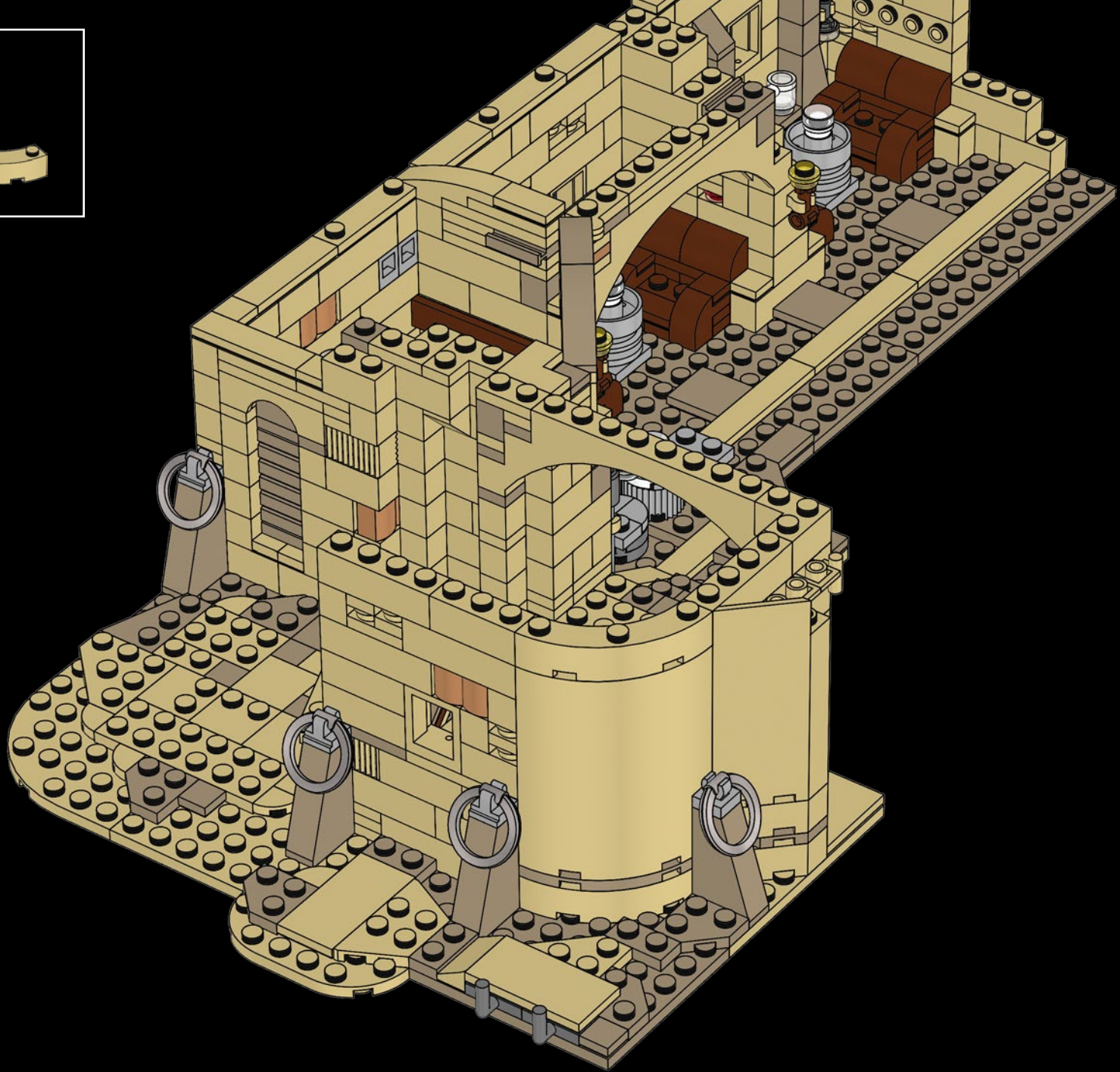

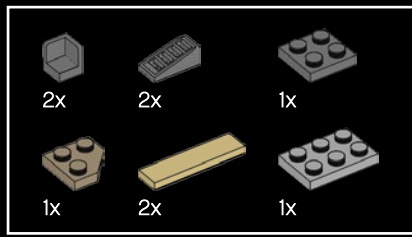

138

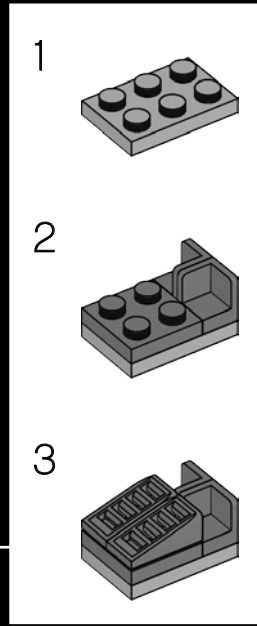
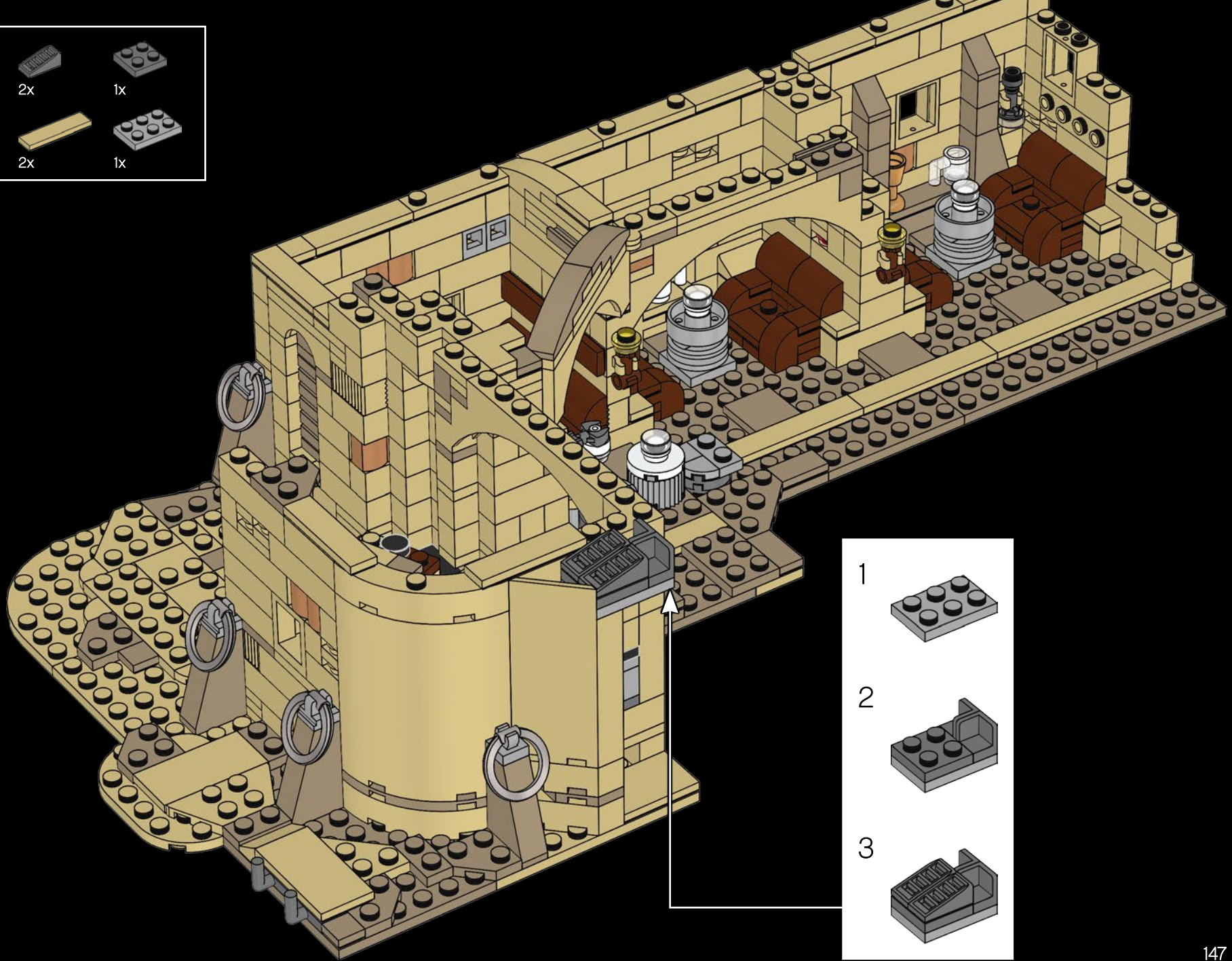

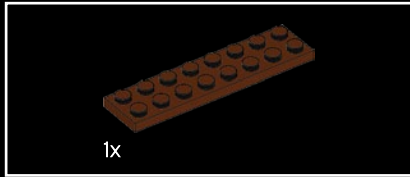
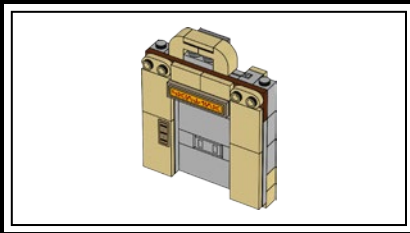

139

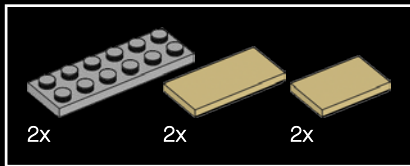
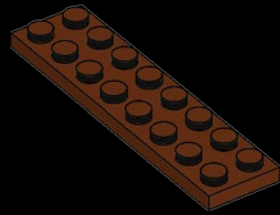

140

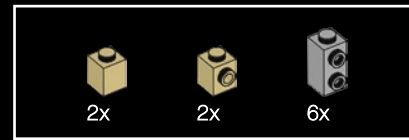
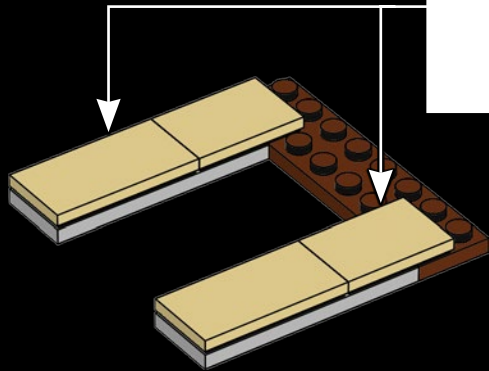
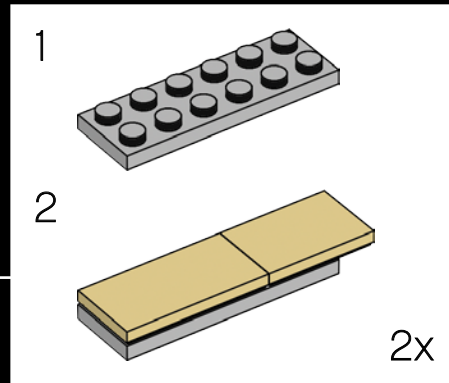

141

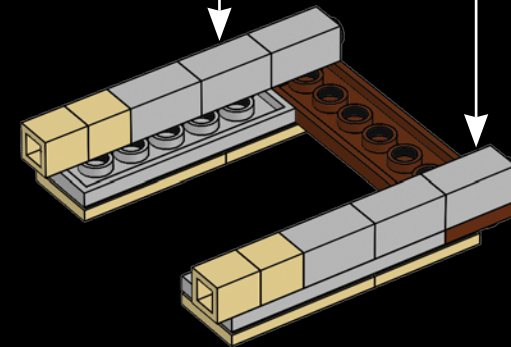
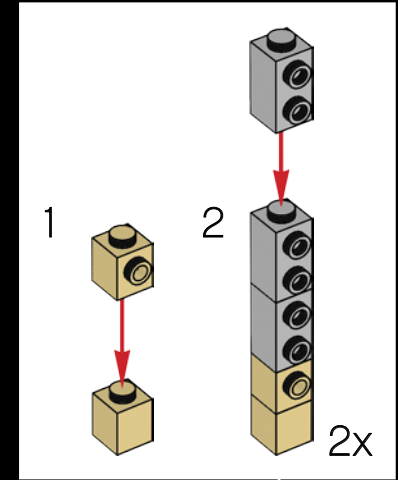

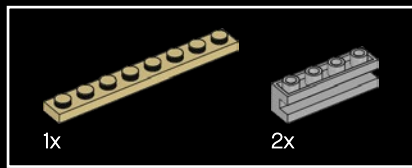

142

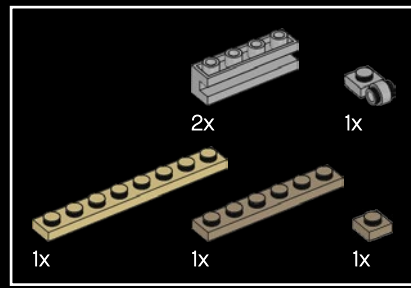
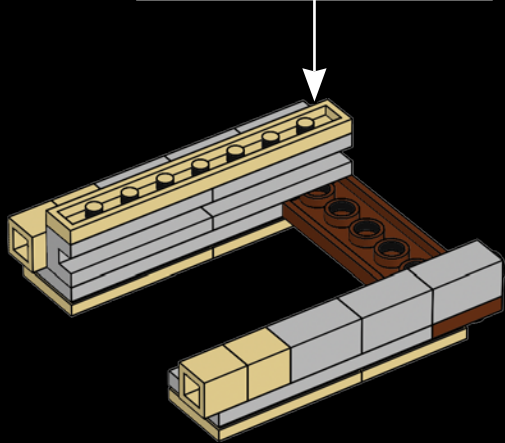
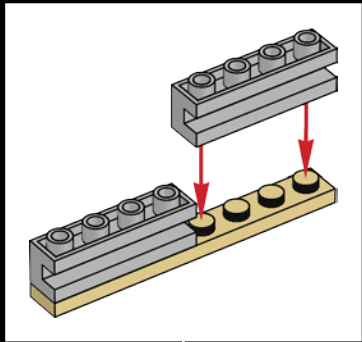

143

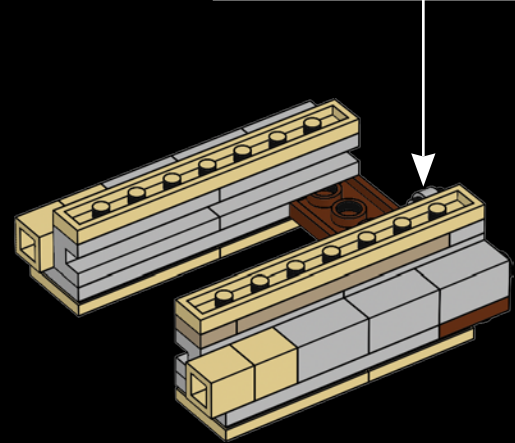
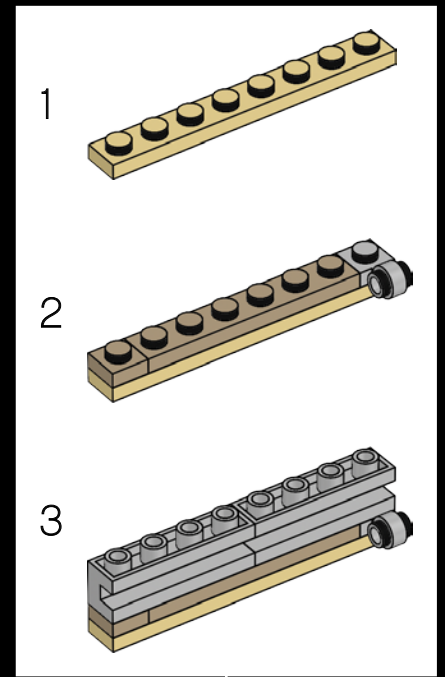

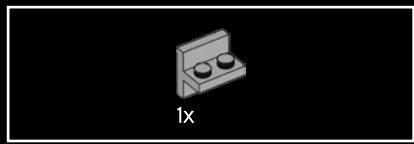

144

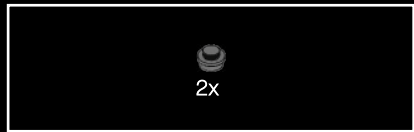

145

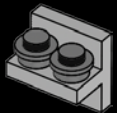

146

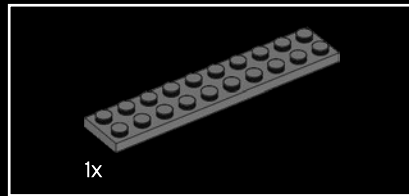
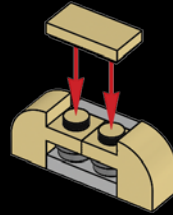

147

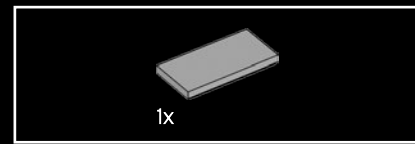
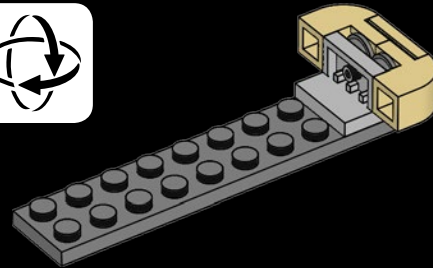

148

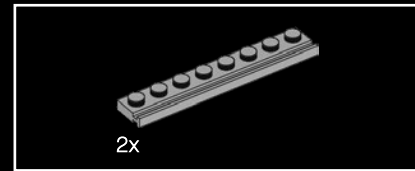
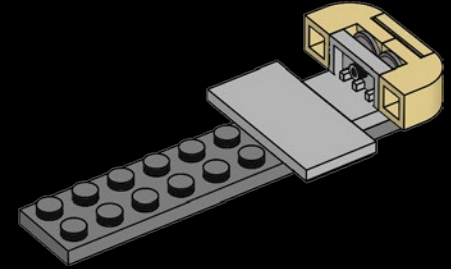

149

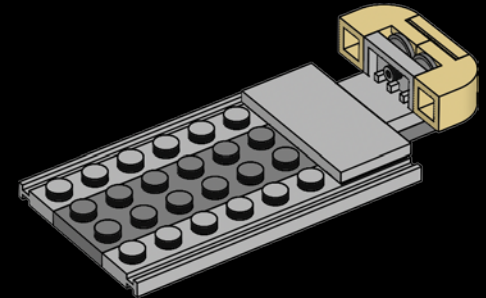

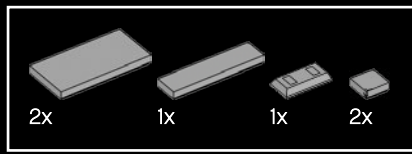

150

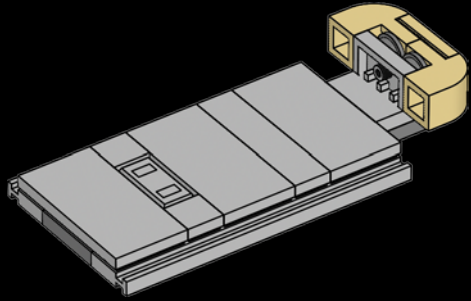

151

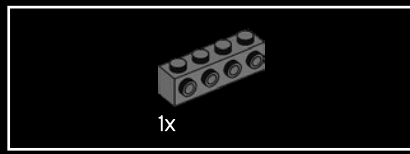
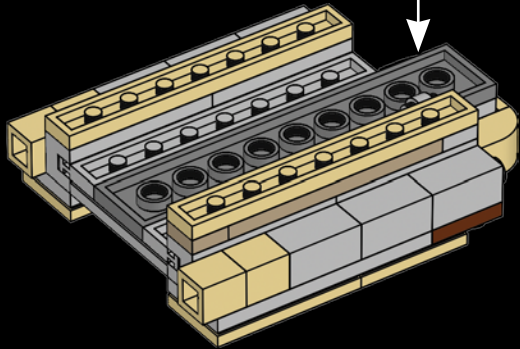

152

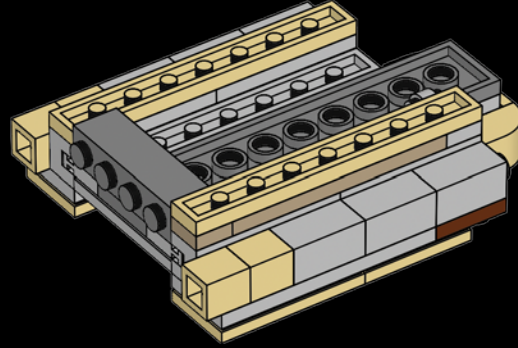

153

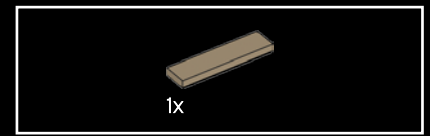
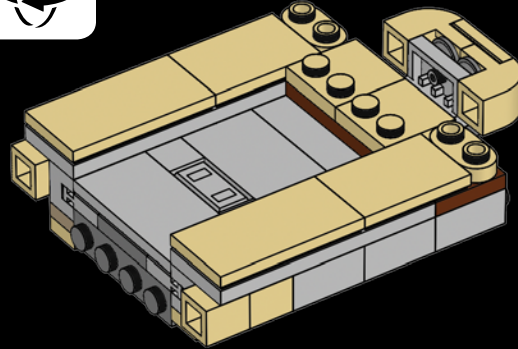

154

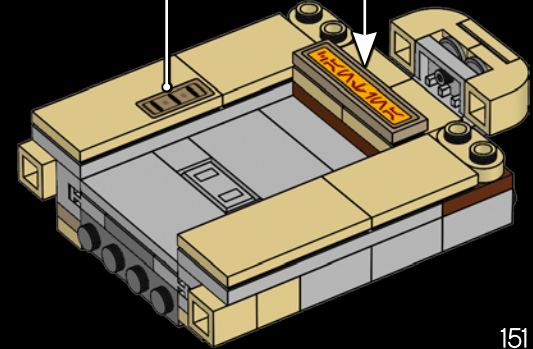
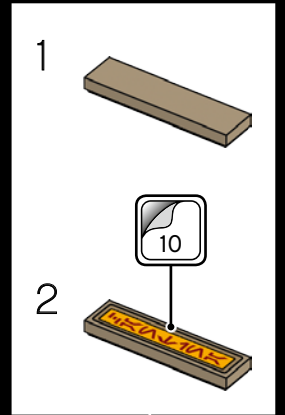

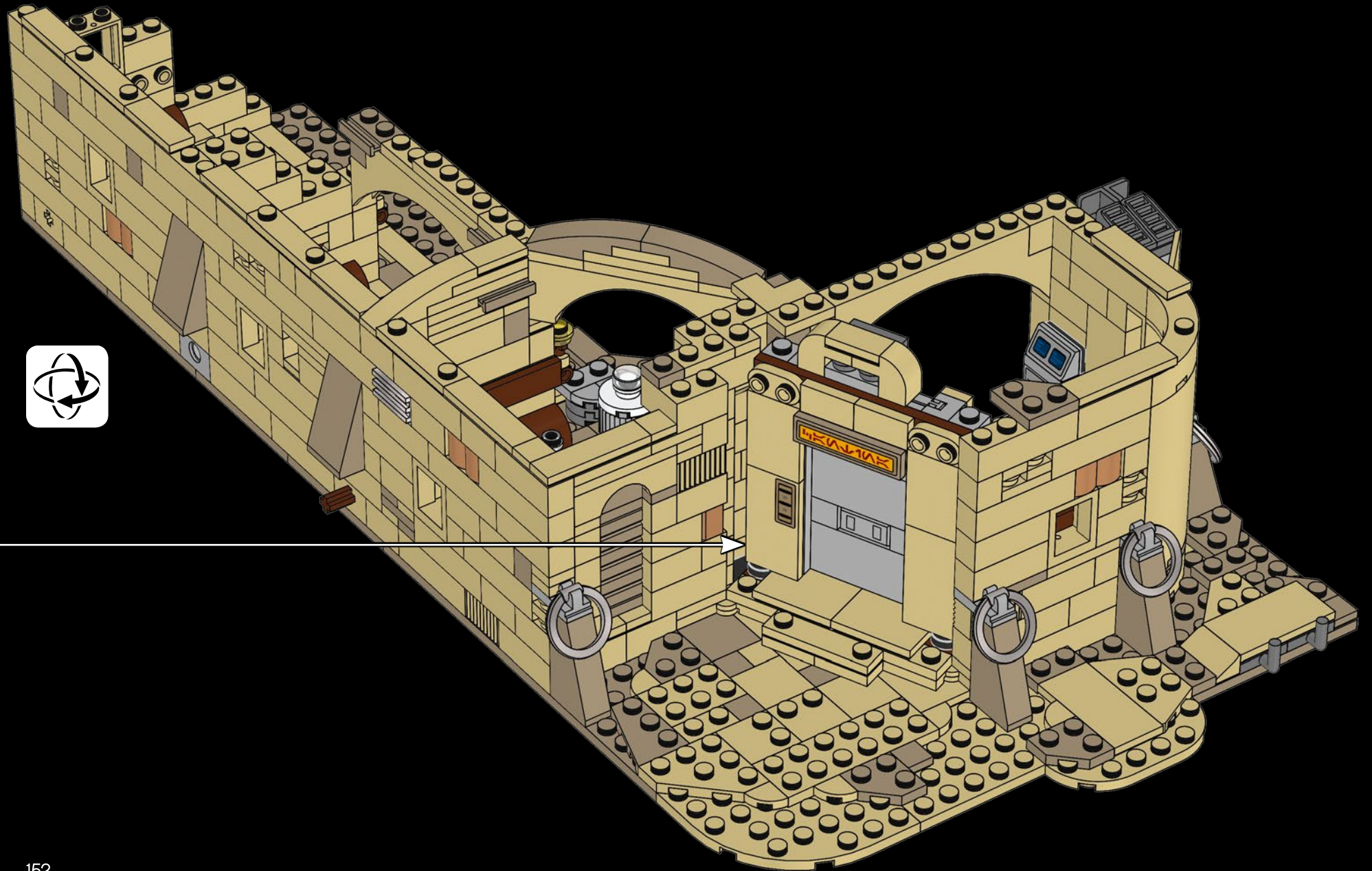

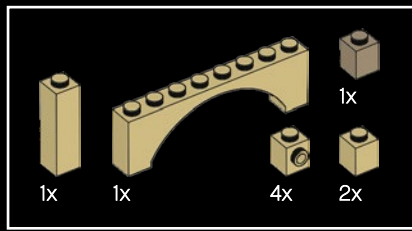

156

1

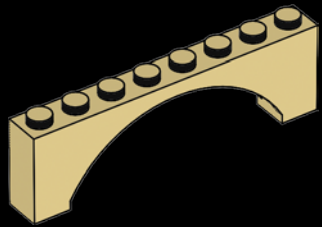

2

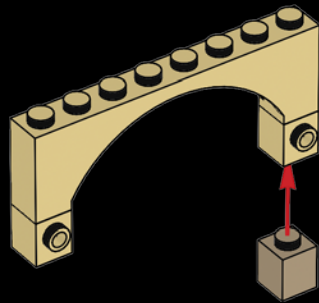

3

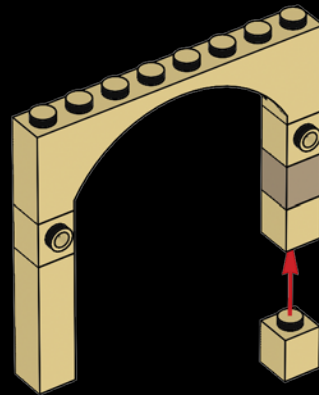

4

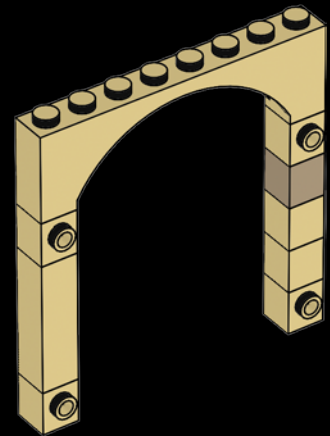

In the film, the Cantina doors open sideways, but in the LEGO version, they slide up. It saves space for opening doors and makes it easier to play out fast escape scenes when you can quickly pull the doors up or down.

Dans le film, les portes de la cantina s'ouvrent latéralement, mais dans la version LEGO, elles glissent vers le haut. Ceci permet de gagner de l'espace pour l'ouverture des portes et facilite la reconstitution des scènes d'évasion, puisque les portes peuvent rapidement être tirées vers le haut ou vers le bas.

En la película, la puerta de la cantina se abre de lado, pero en la versión LEGO se desliza hacia arriba. Así se necesita menos espacio para abrirla y resulta más fácil interpretar escenas de escape a toda velocidad, pues se puede subir y bajar rápidamente.

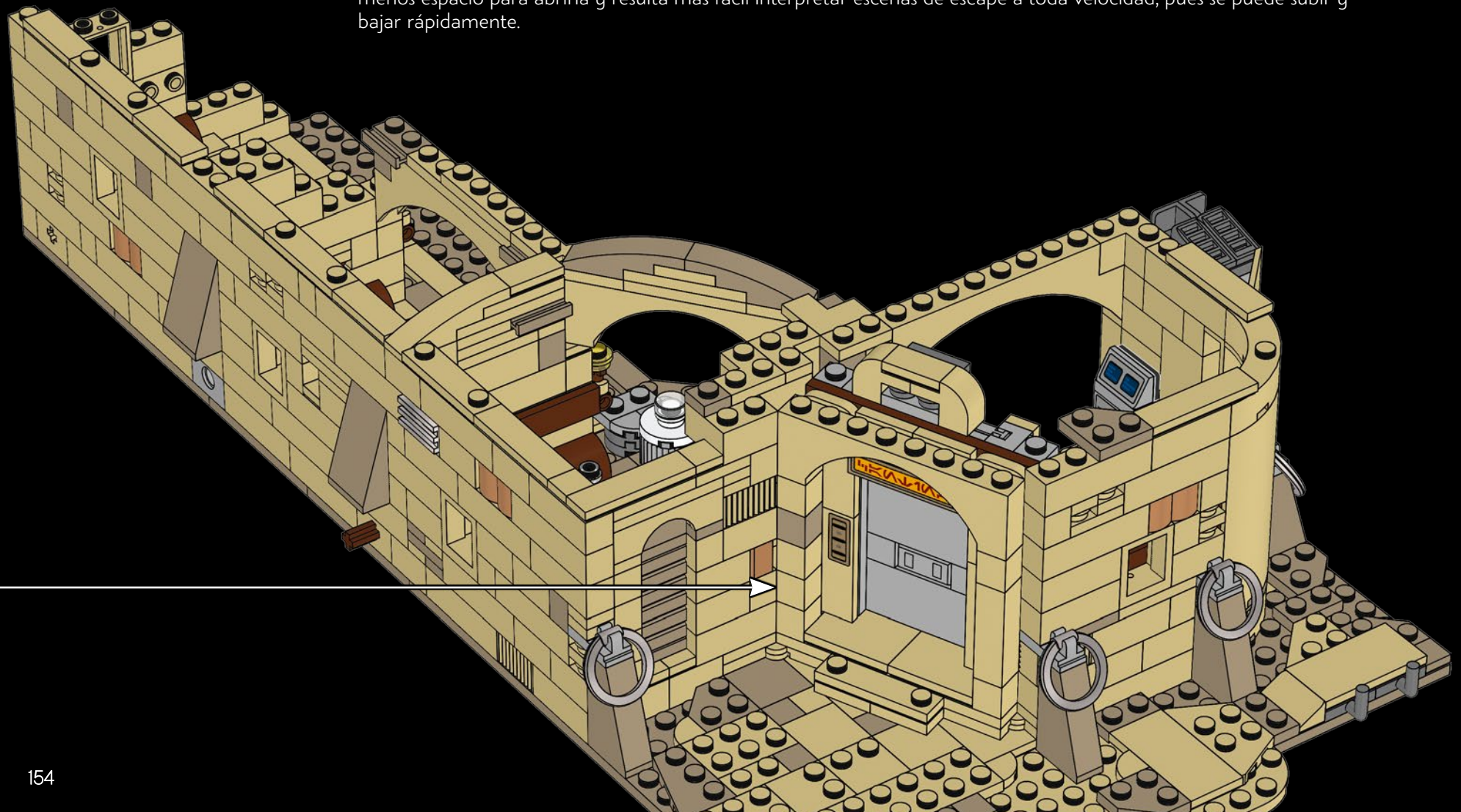

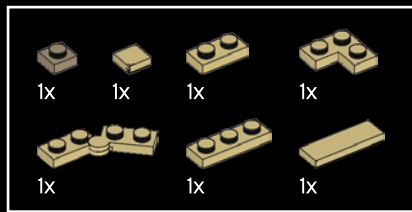

157

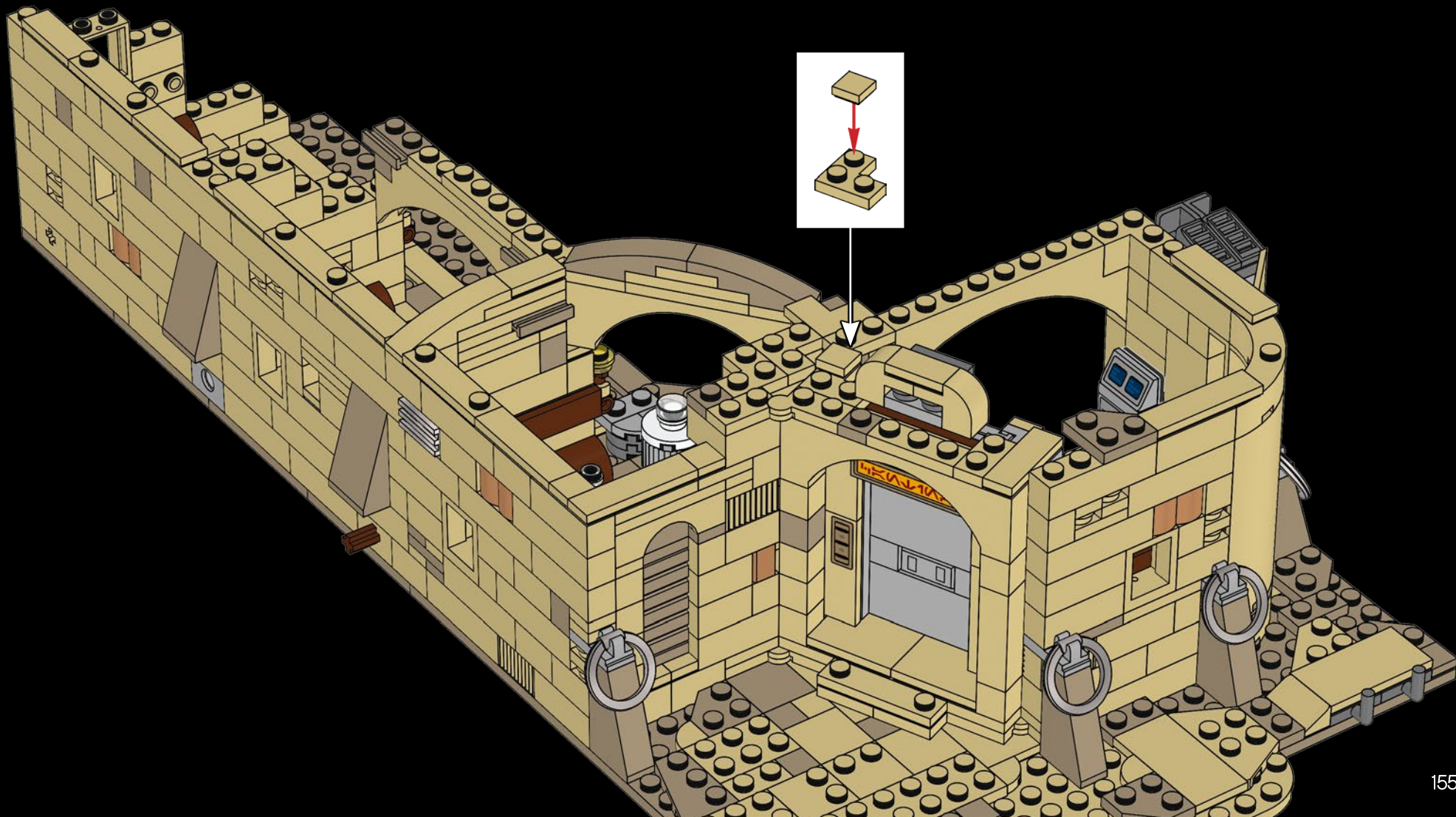

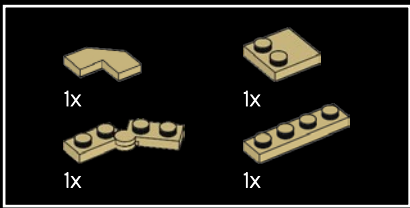

158

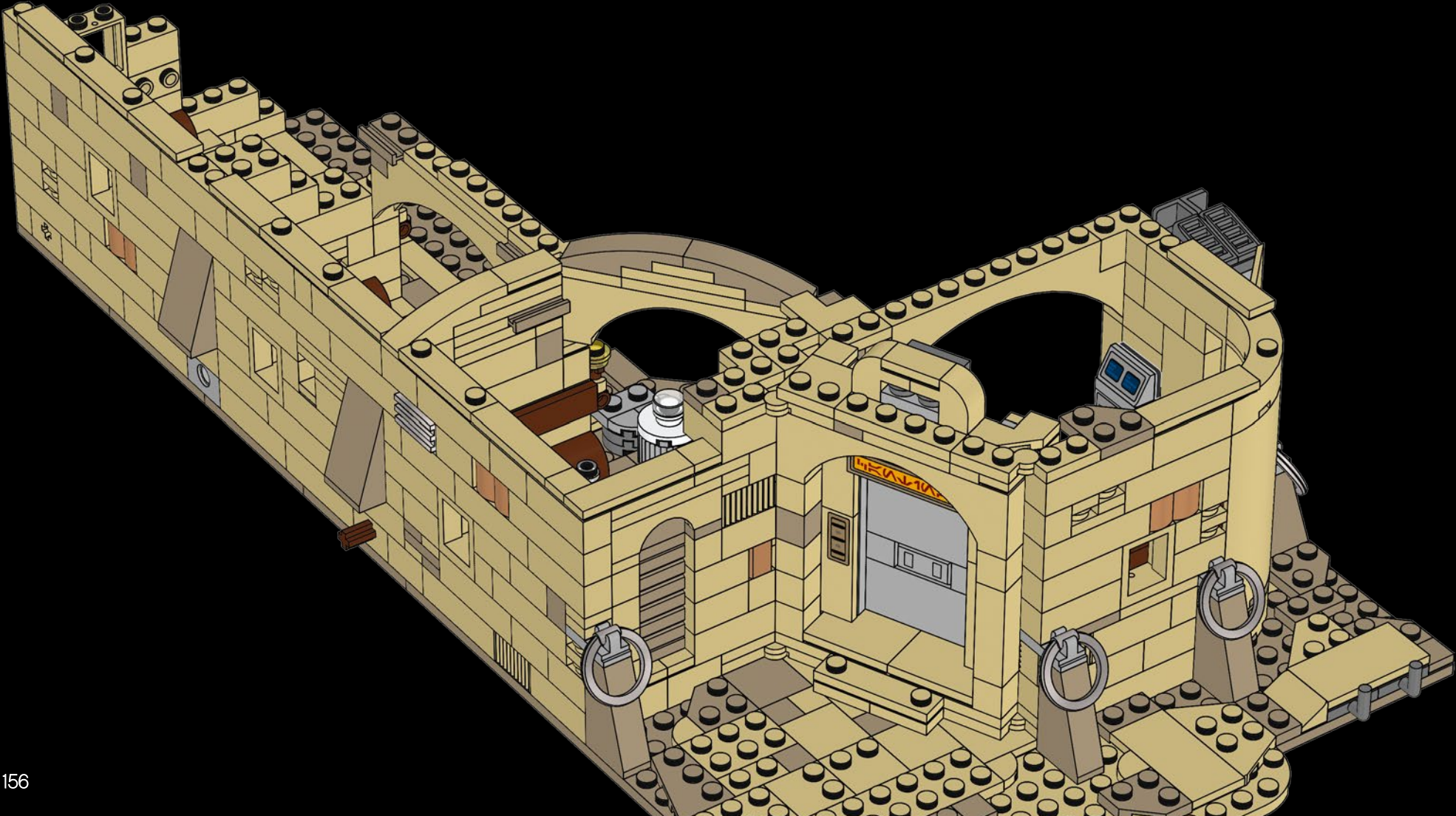

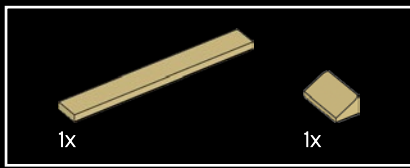

159

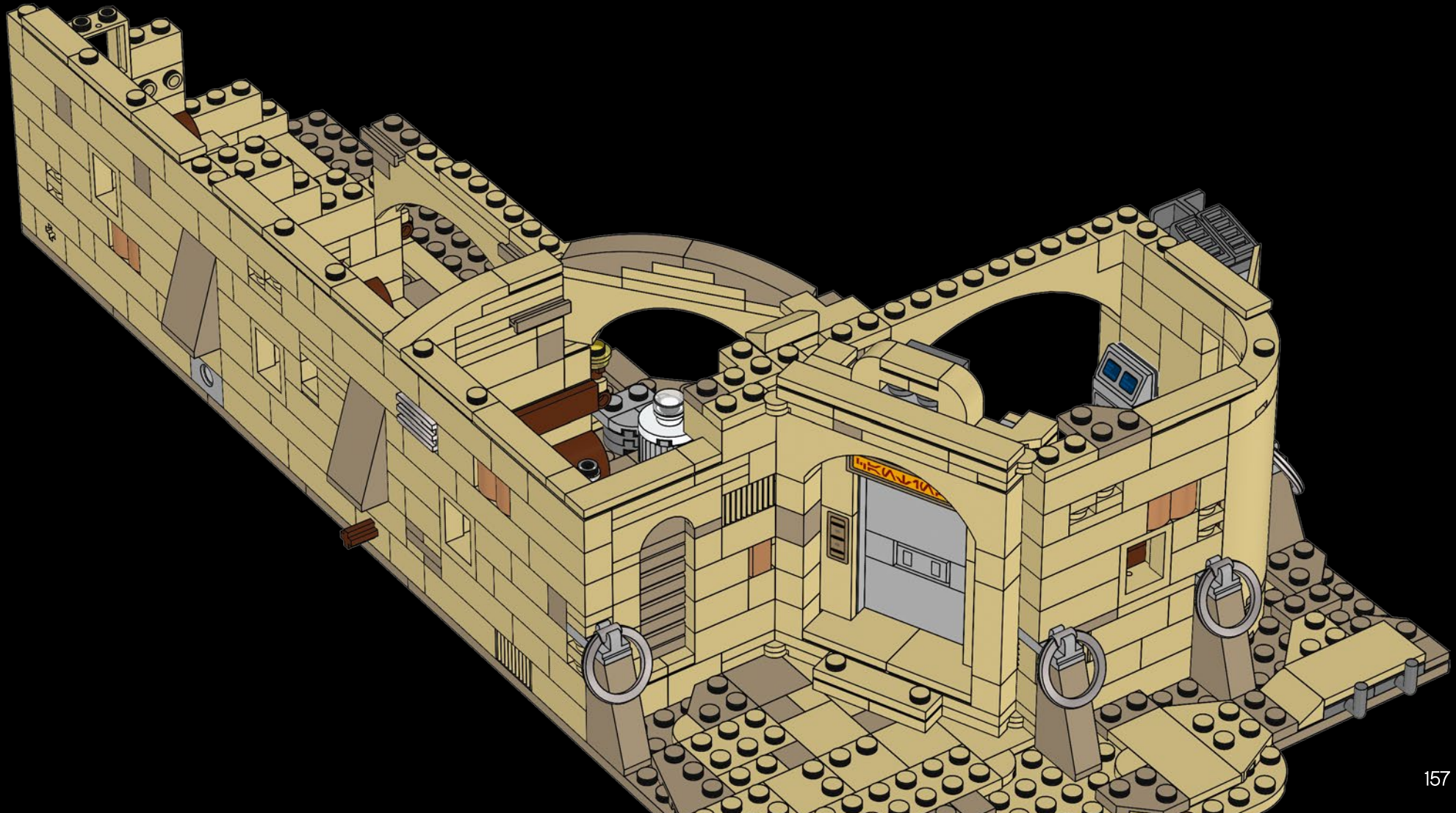

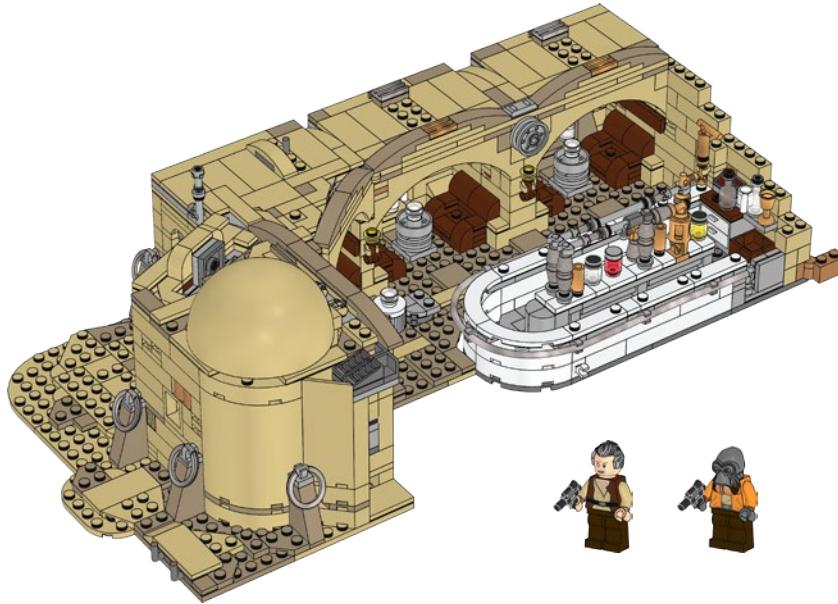
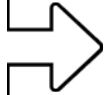

Ponda Baba, an associate and friend to Dr. Evazan, is an Aqualish thug who once smuggled spices for Jabba the Hutt. Bored and looking for excitement, Ponda picked a fight with the wrong farm boy and ended up minus one arm.

Ponda Baba, associé et ami du Dr Evazan, est un voyou Aqualish qui faisait jadis passer des épices en contrebande pour Jabba le Hutt. Las et à la recherche d'émotions fortes, Ponda a eu la mauvaise idée de s'en prendre à Luke et s'en est sorti avec un bras en moins.

Ponda Baba, socio y amigo del Dr. Evazan, es un matón Aqualish que pasaba especias de contrabando para Jabba el Hutt. Aburrido y ansioso de emoción, Ponda eligió al granjero equivocado para pelearse y acabó con un brazo menos.

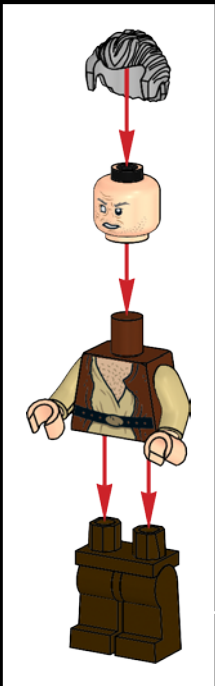

Believe it or not, Dr. Cornelius Evazan is, in fact, a doctor. He was once a promising surgeon, but eventually became notorious for conducting twisted medical experiments on his patients. He has the death sentence on 12 systems.

Croyez-le ou non, Dr Cornelius Evazan est, en fait, un médecin. Autrefois un chirurgien prometteur, il est plus tard devenu célèbre pour avoir réalisé des expériences médicales sordides sur ses patients. Il est condamné à la peine de mort dans 12 systèmes.

Lo creas o no, el Dr. Cornelius Evazan es todo un médico. Llegó a ser un cirujano prometedor, pero acabó haciéndose tristemente famoso por los retorcidos experimentos a los que sometía a sus pacientes. Ha sido condenado a muerte en 12 sistemas.



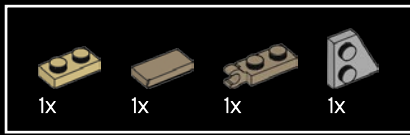

160

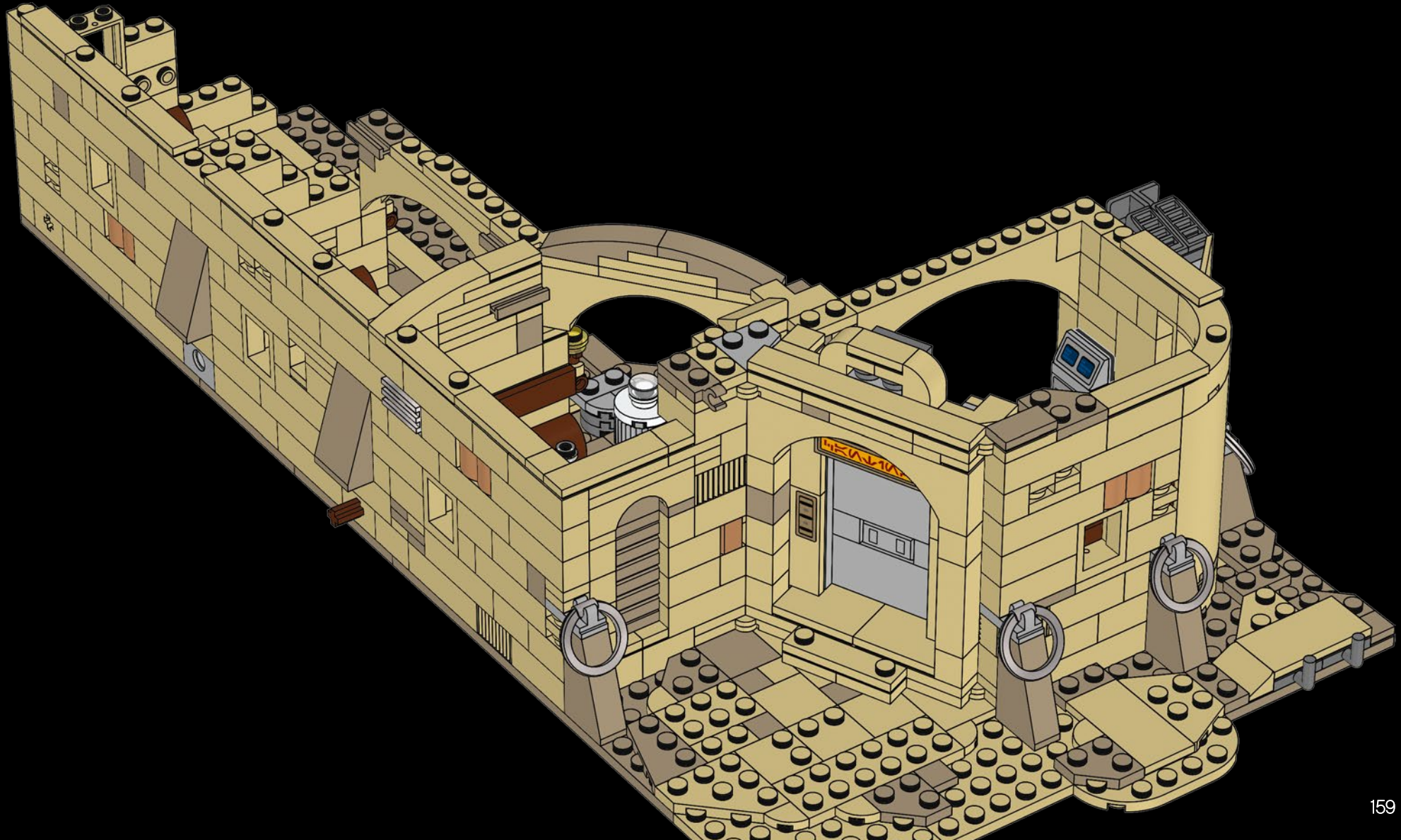

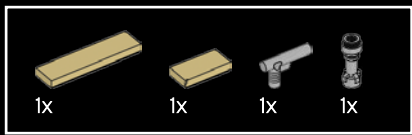

161

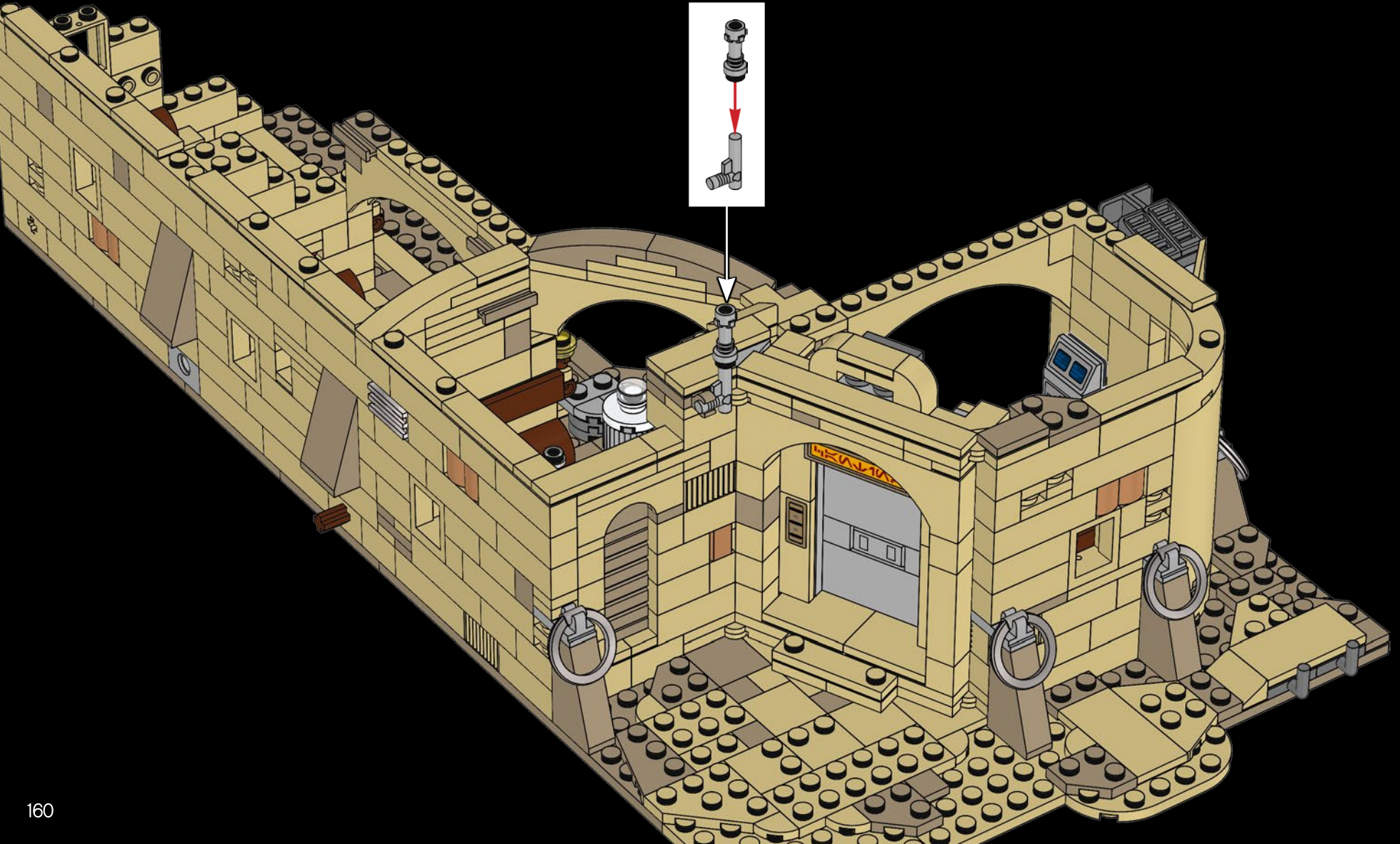

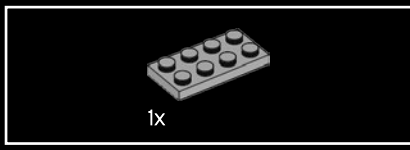

162

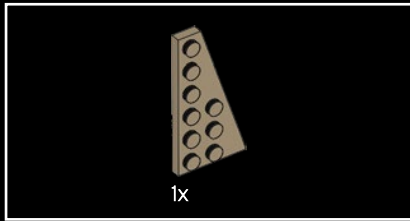

163

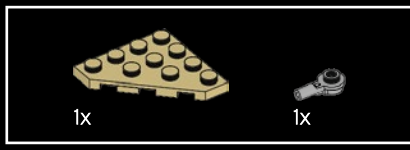
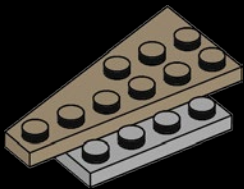

164

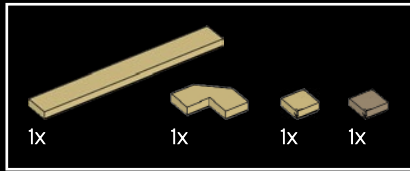
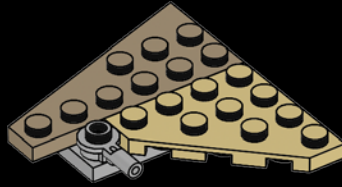

165

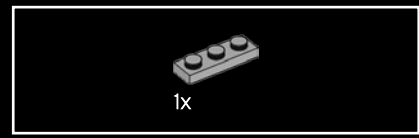
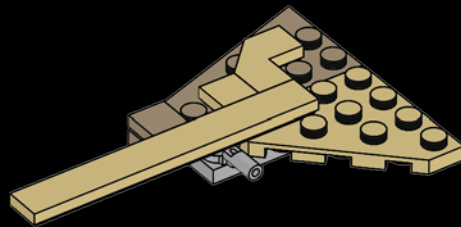

166

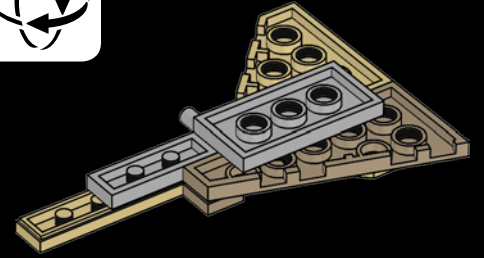

167

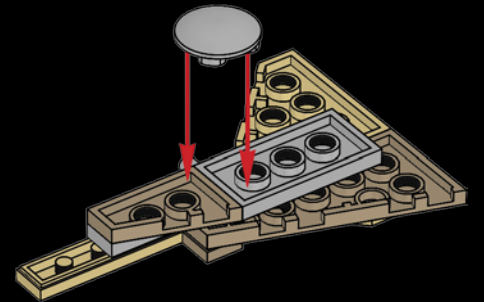





169

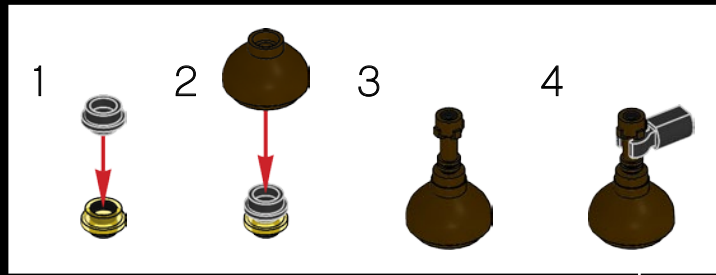
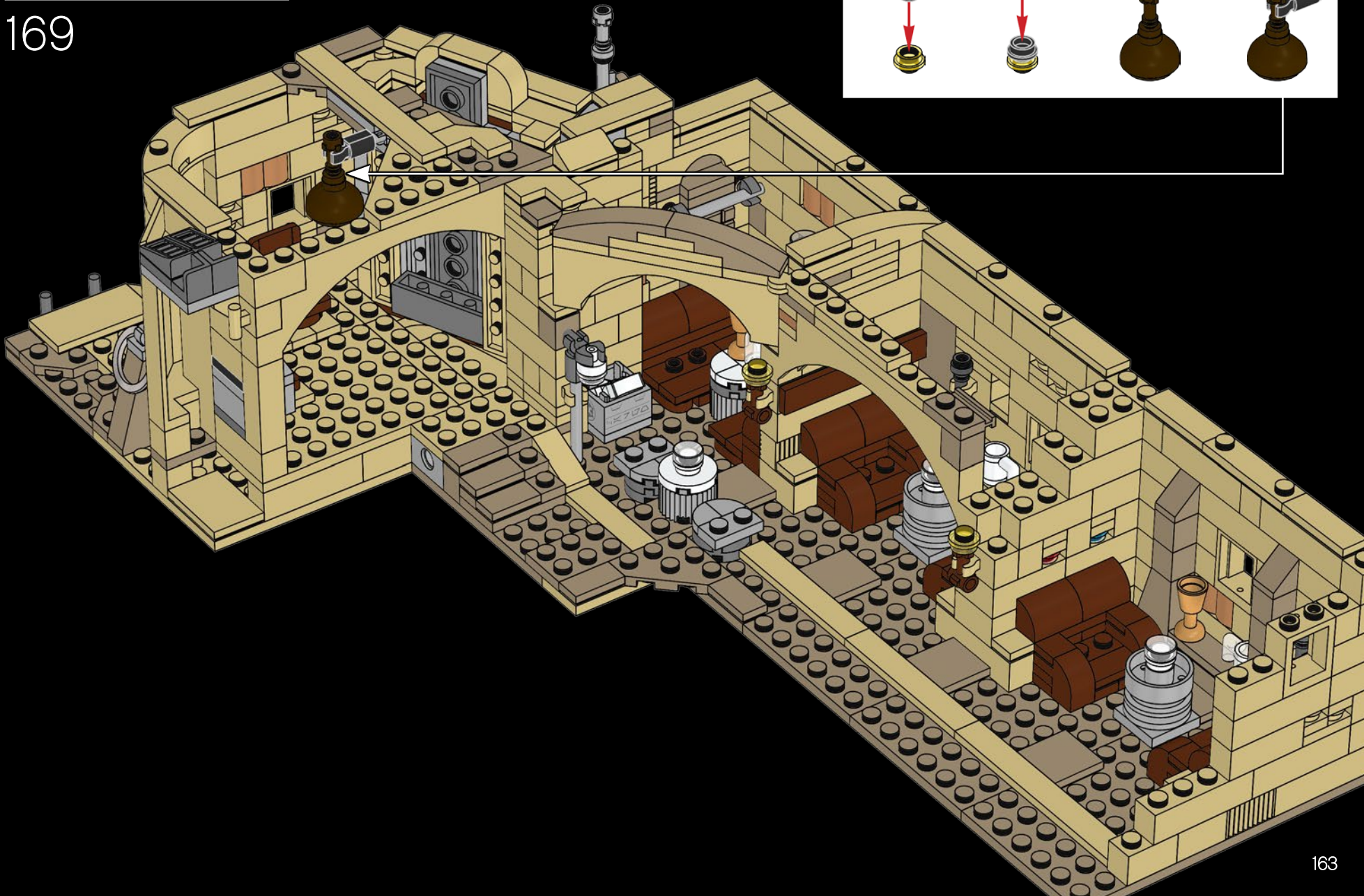



170

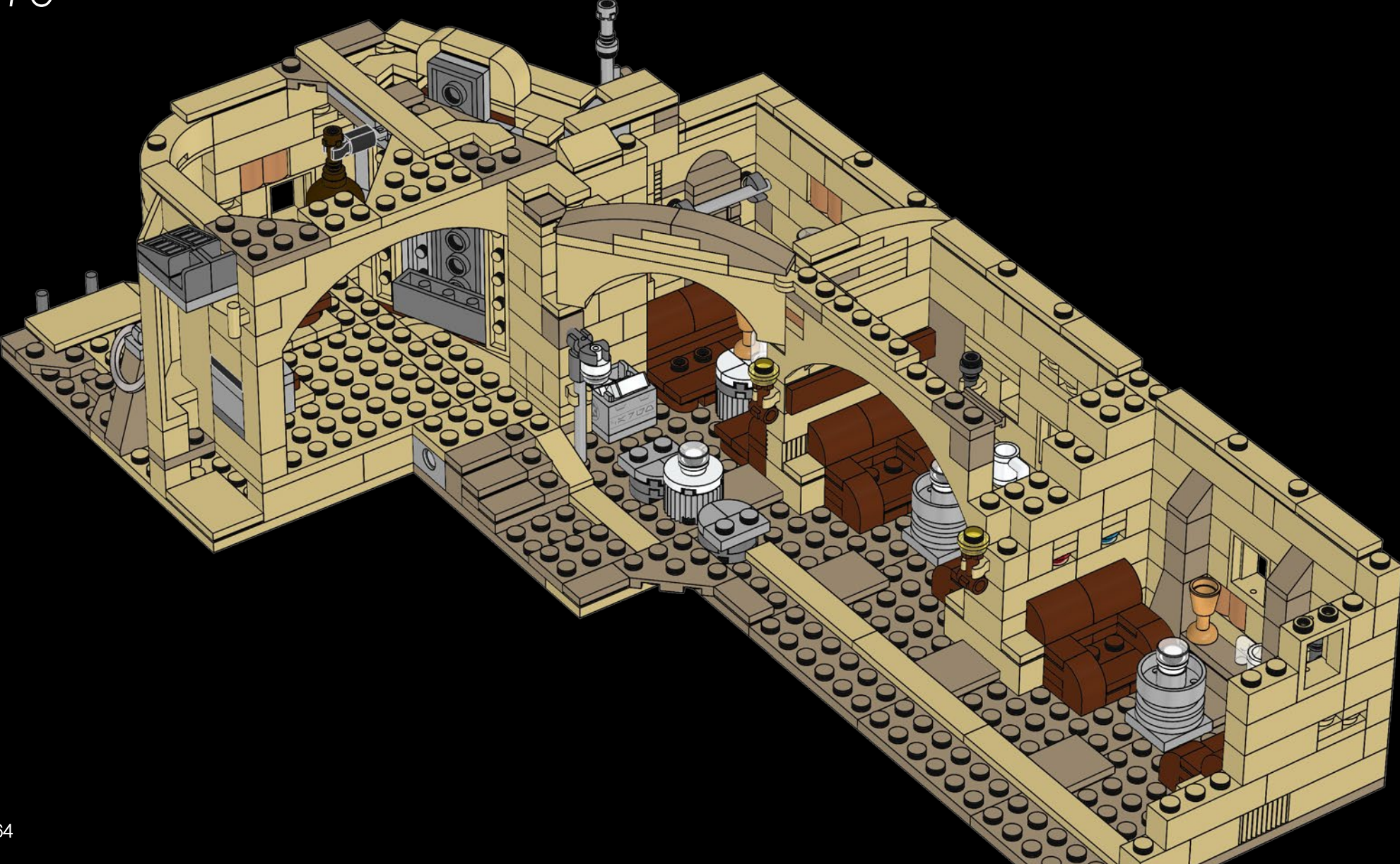

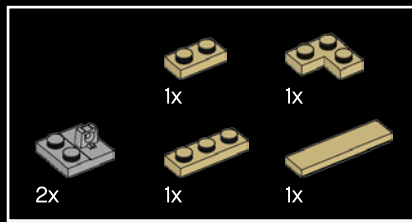

171

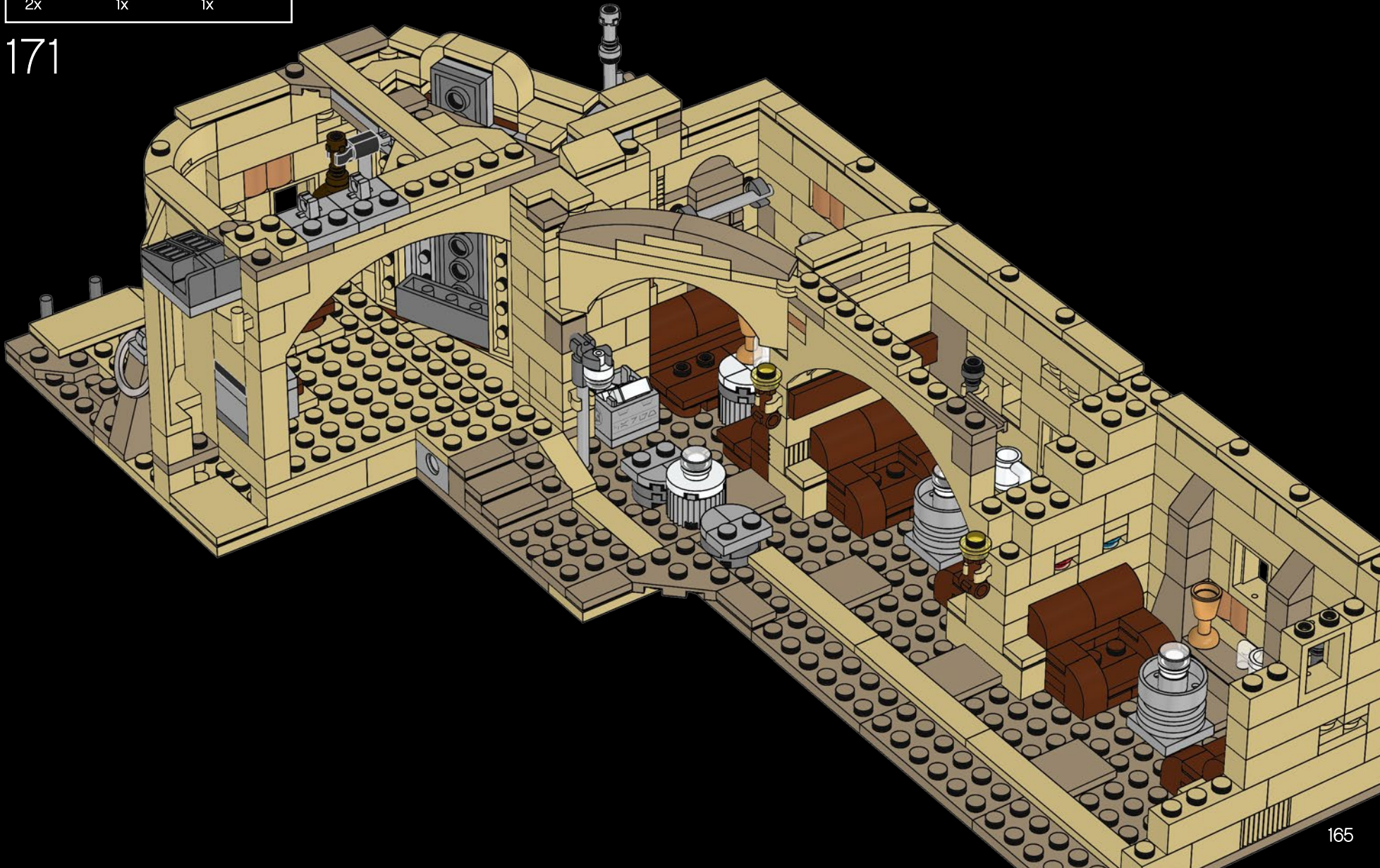

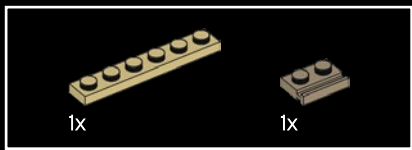

172

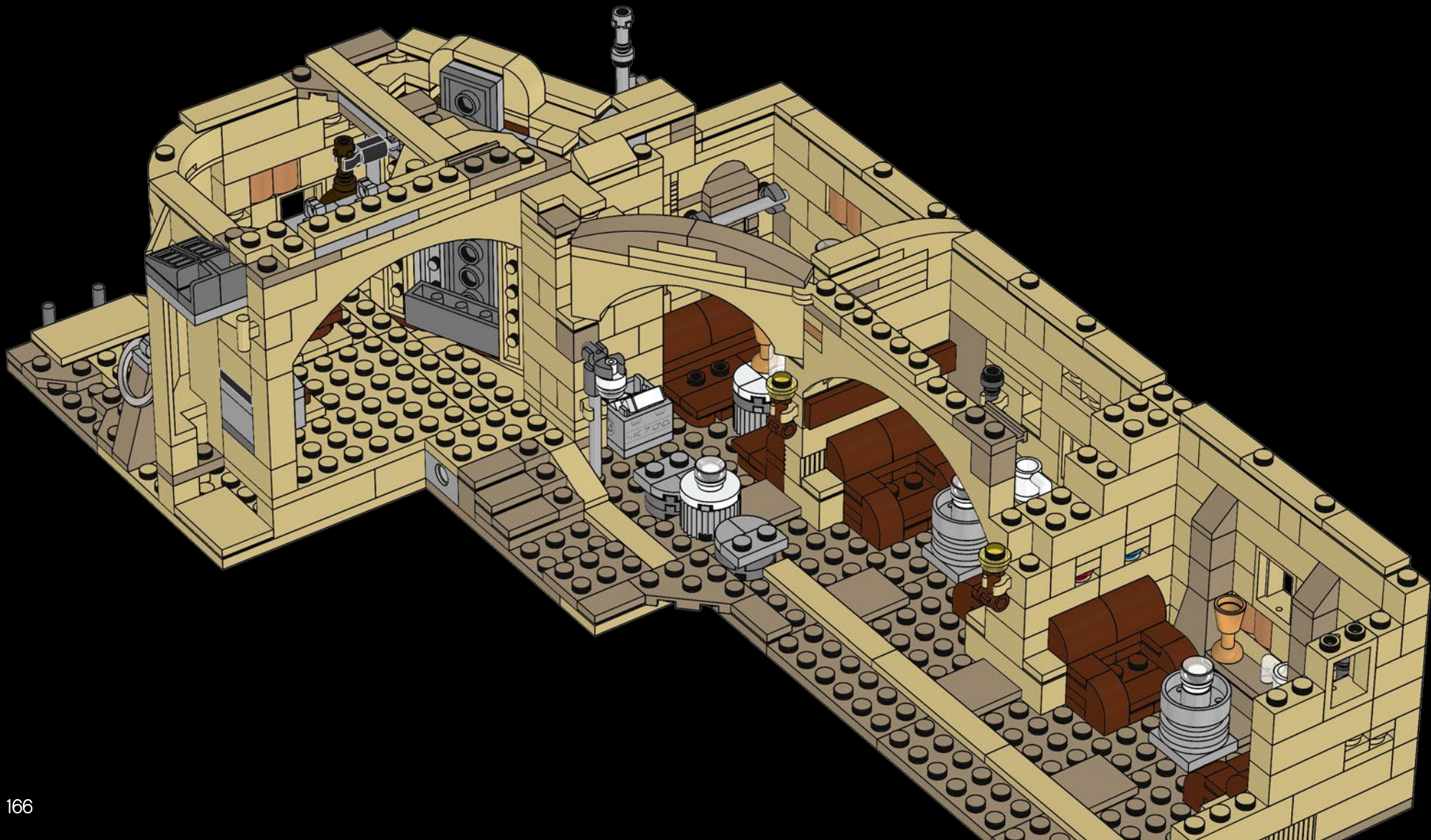

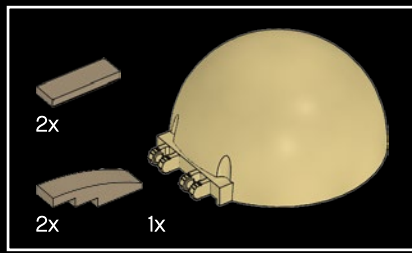

173

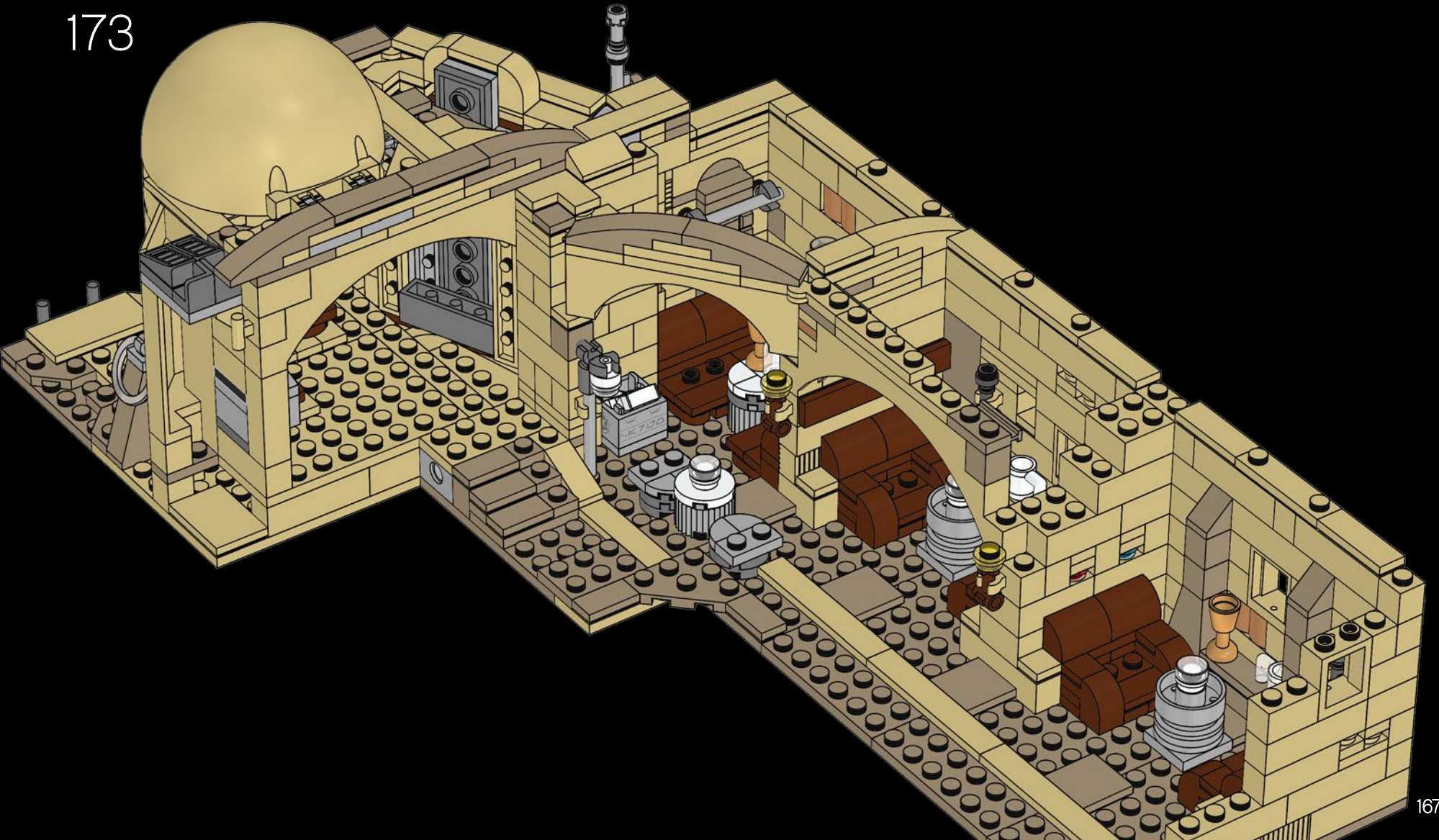

174

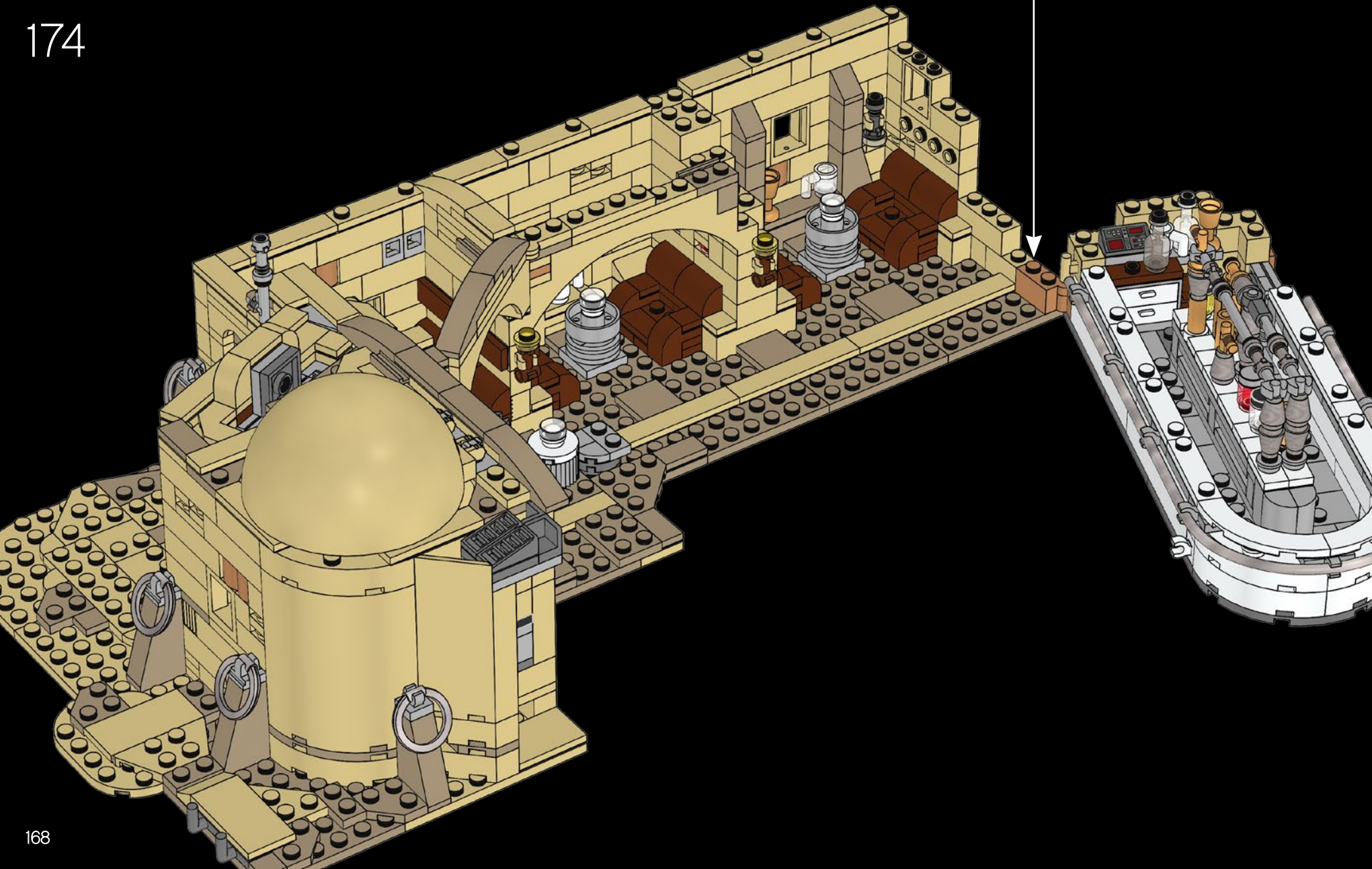

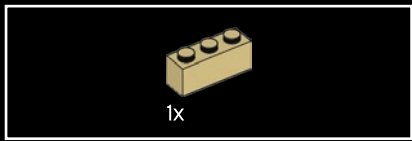

175

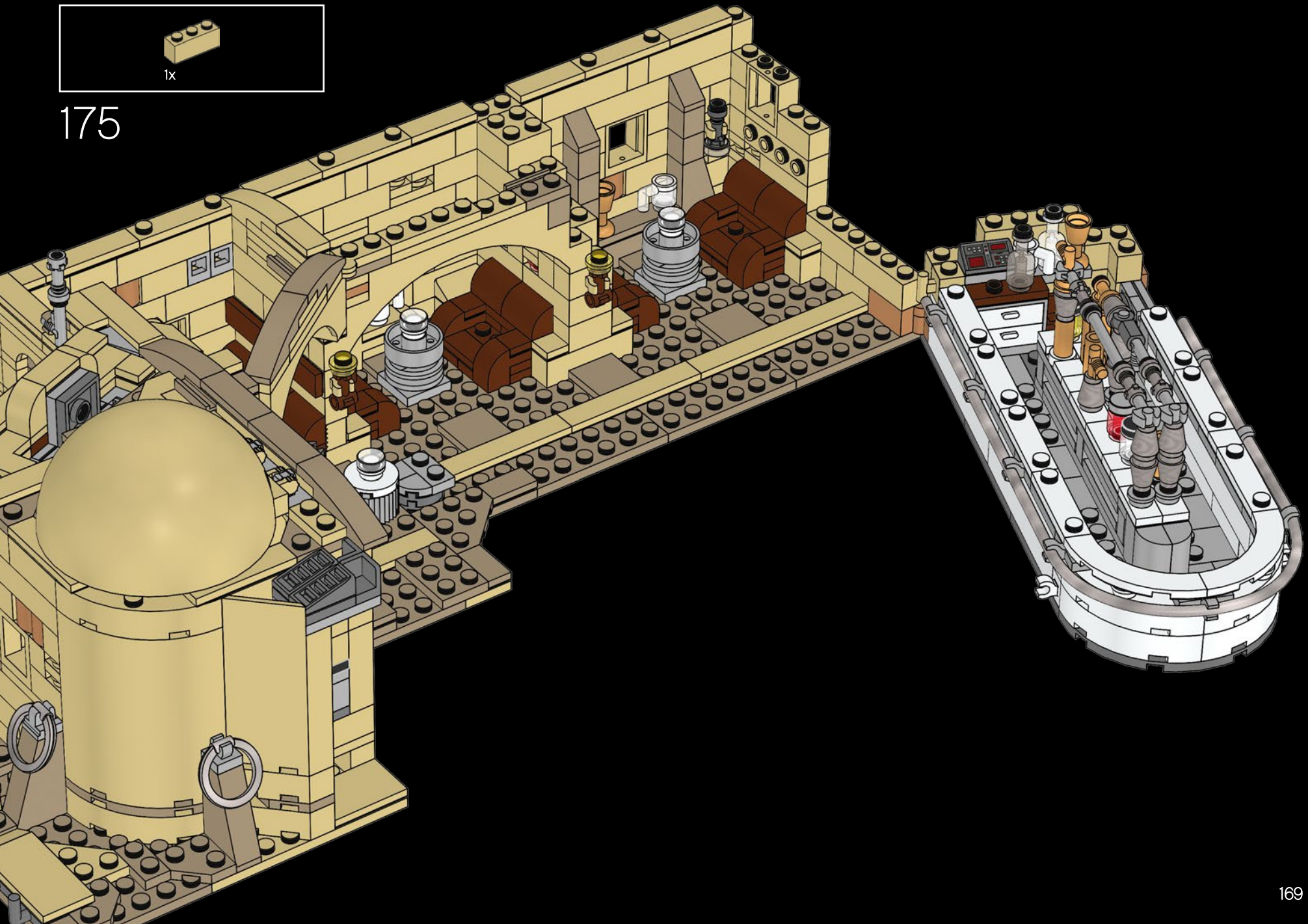

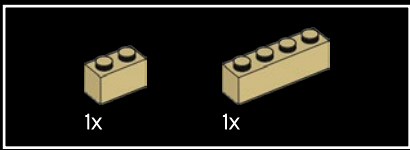

176

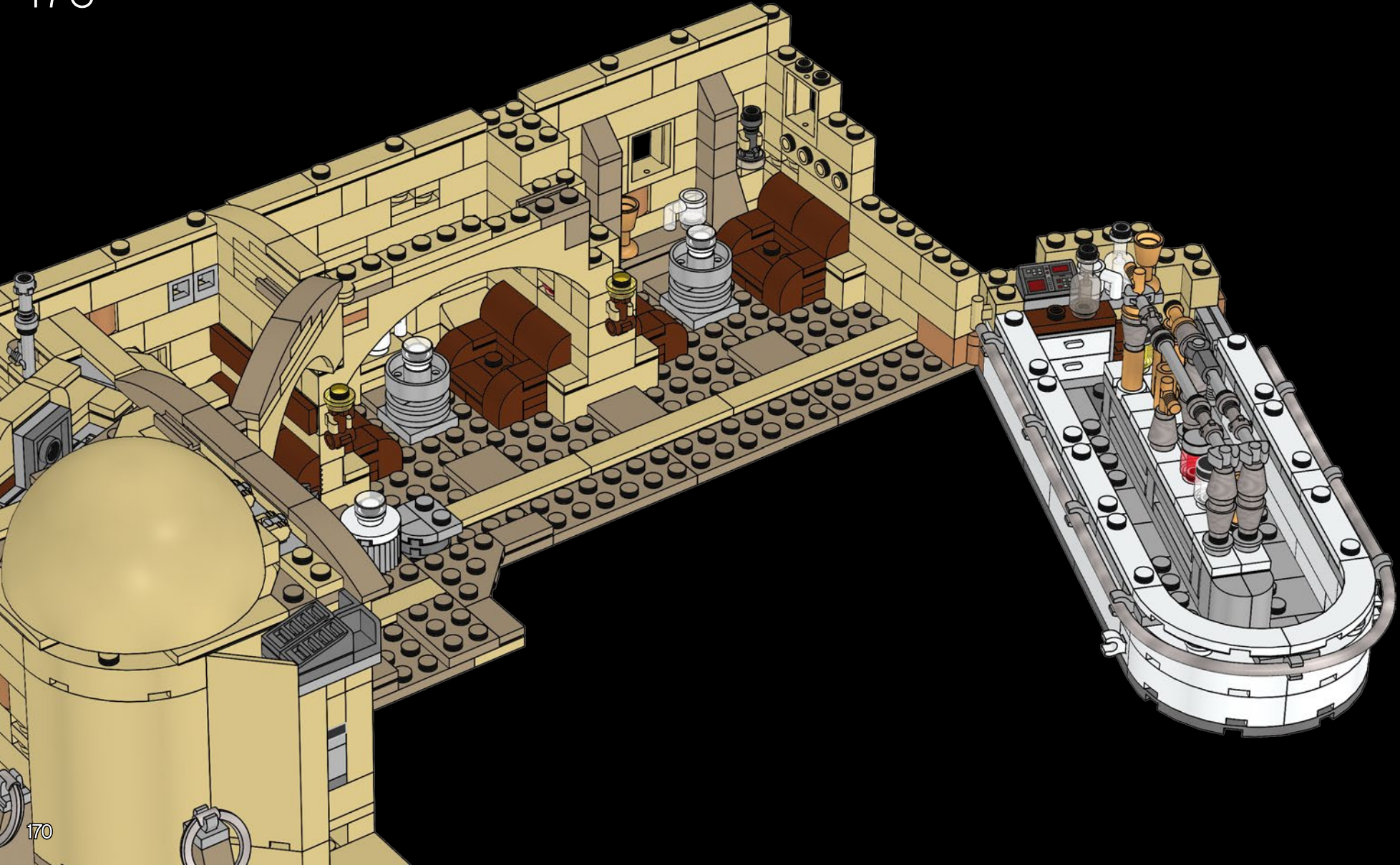

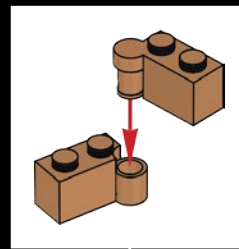
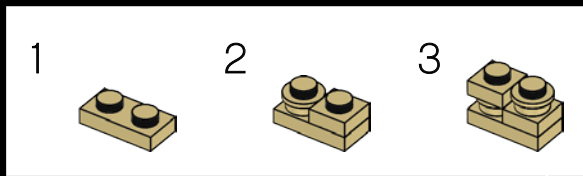
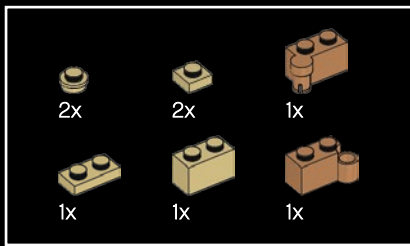

177

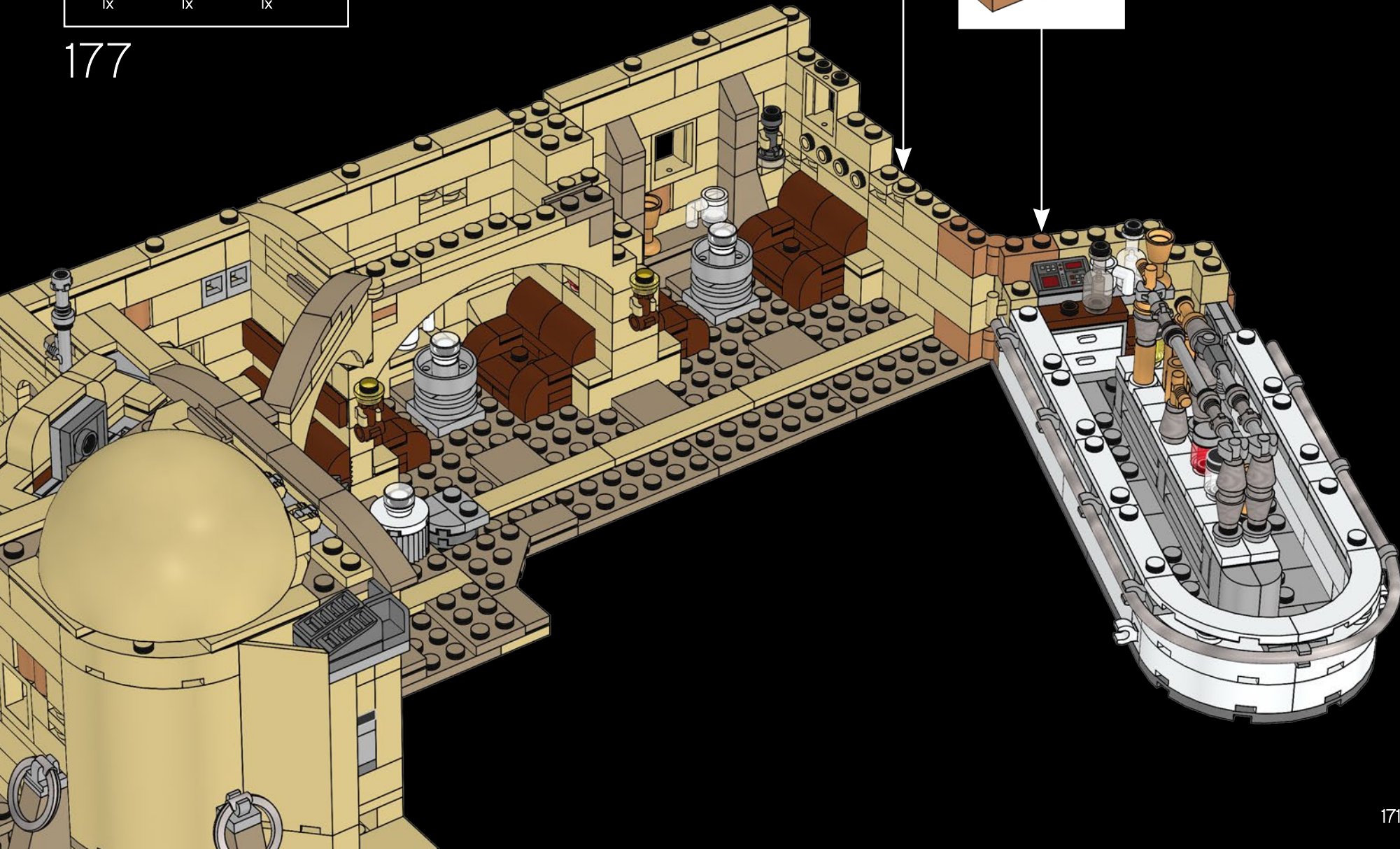

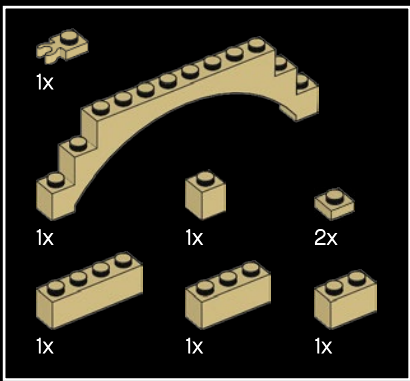

178

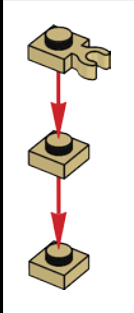
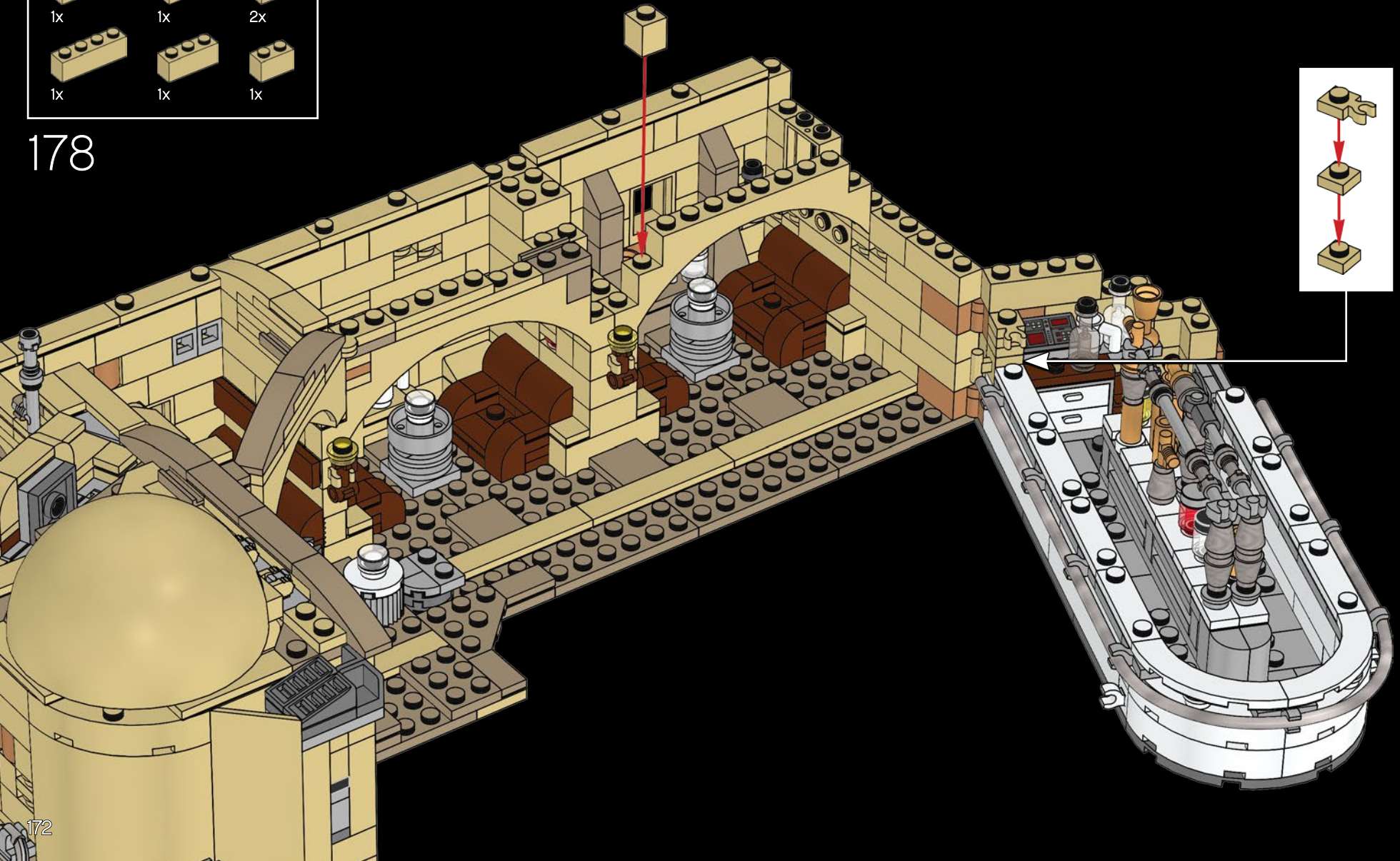

172

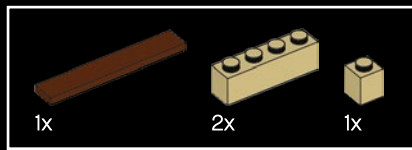

179

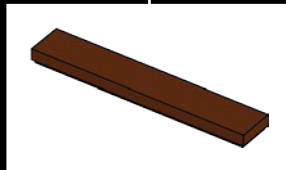
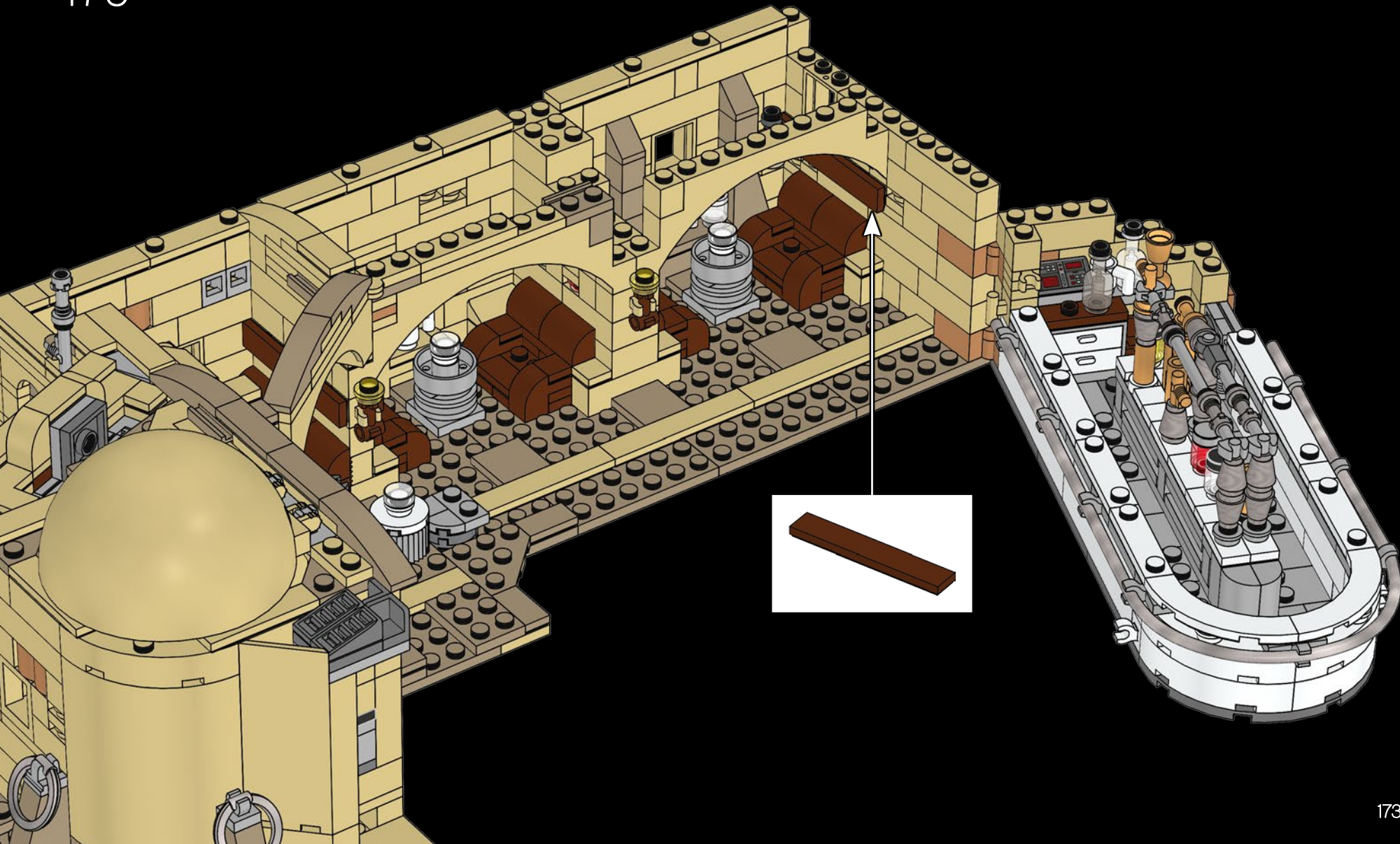

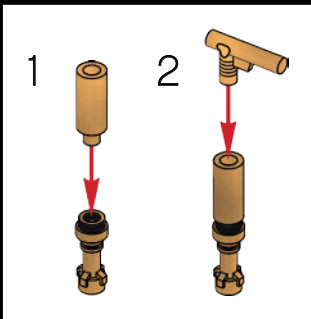
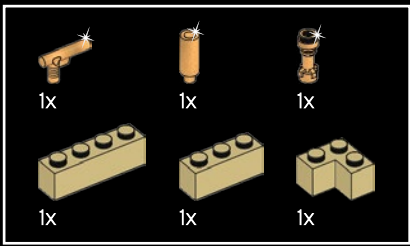

180

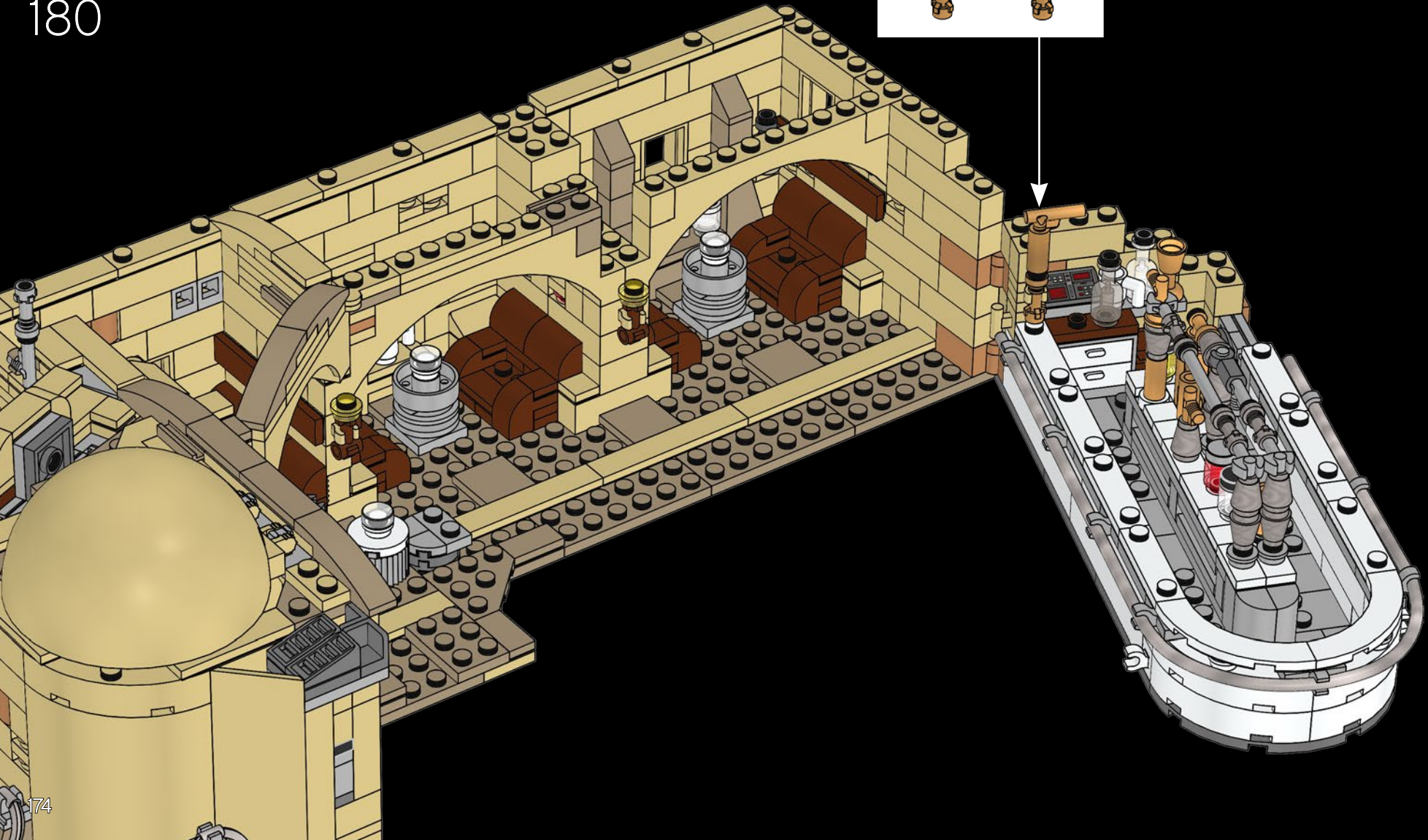

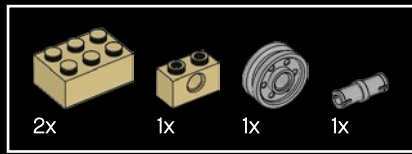

181

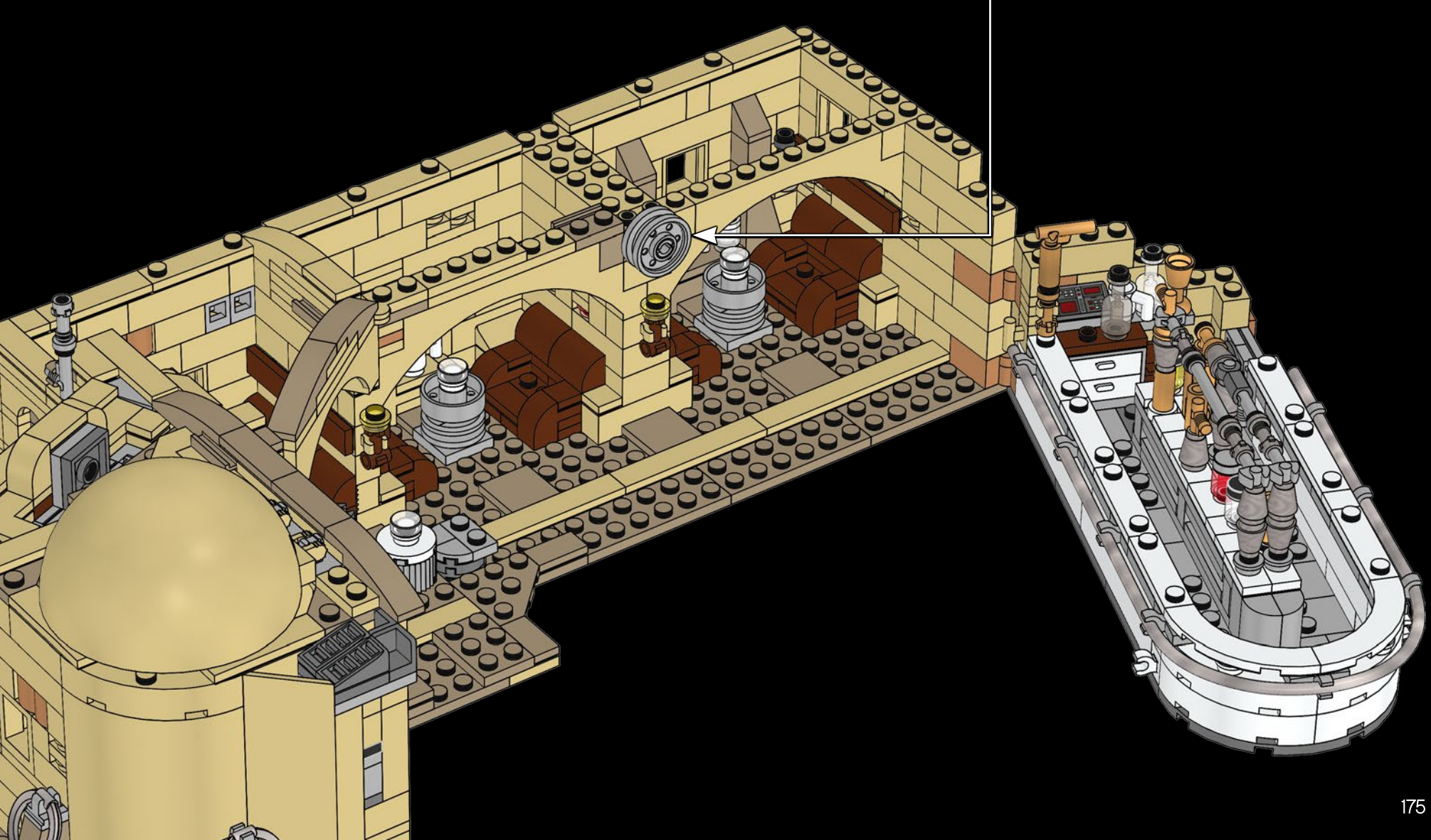
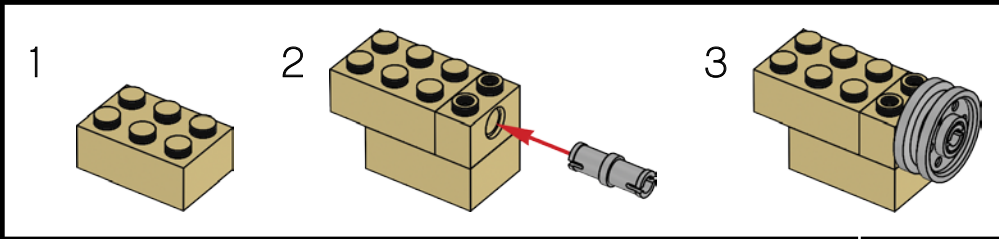

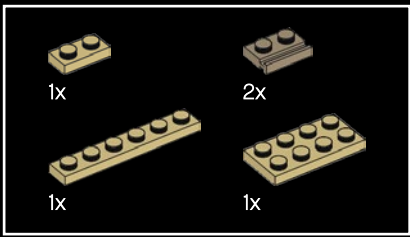

182

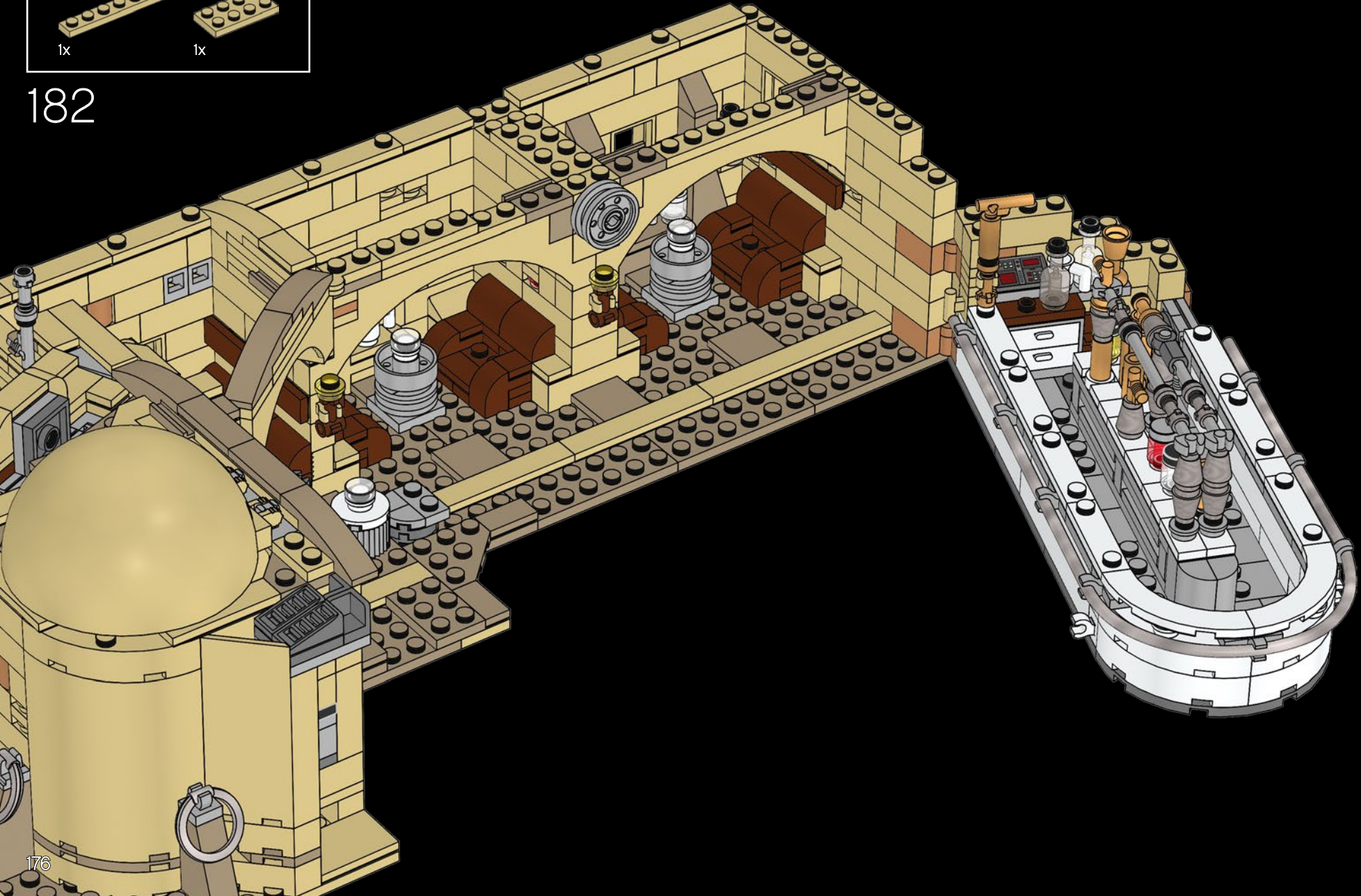

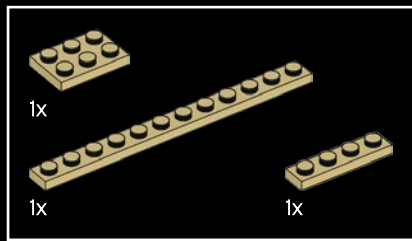

183

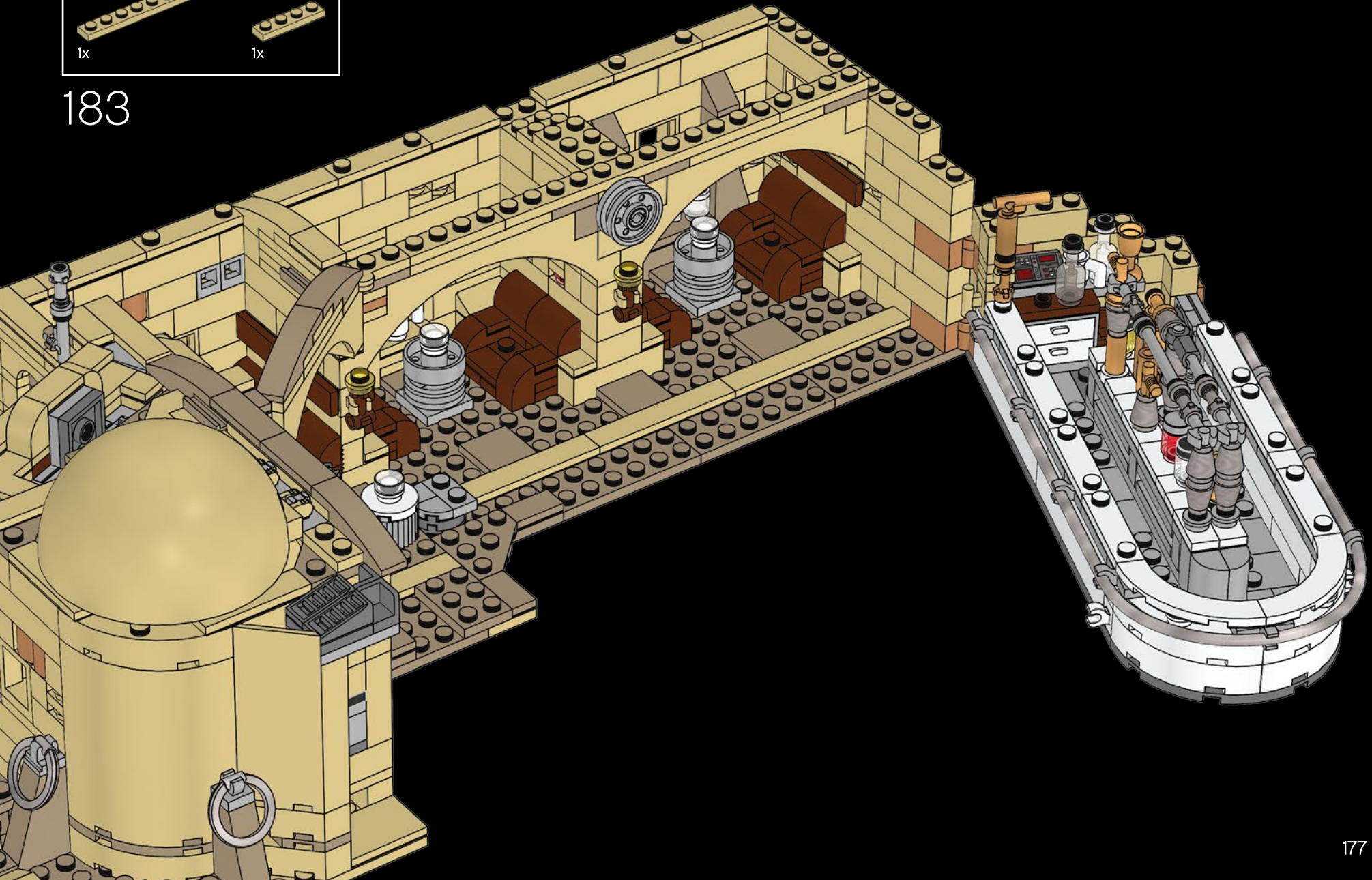

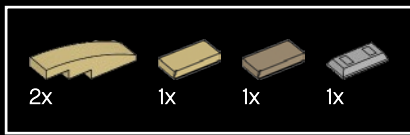

184

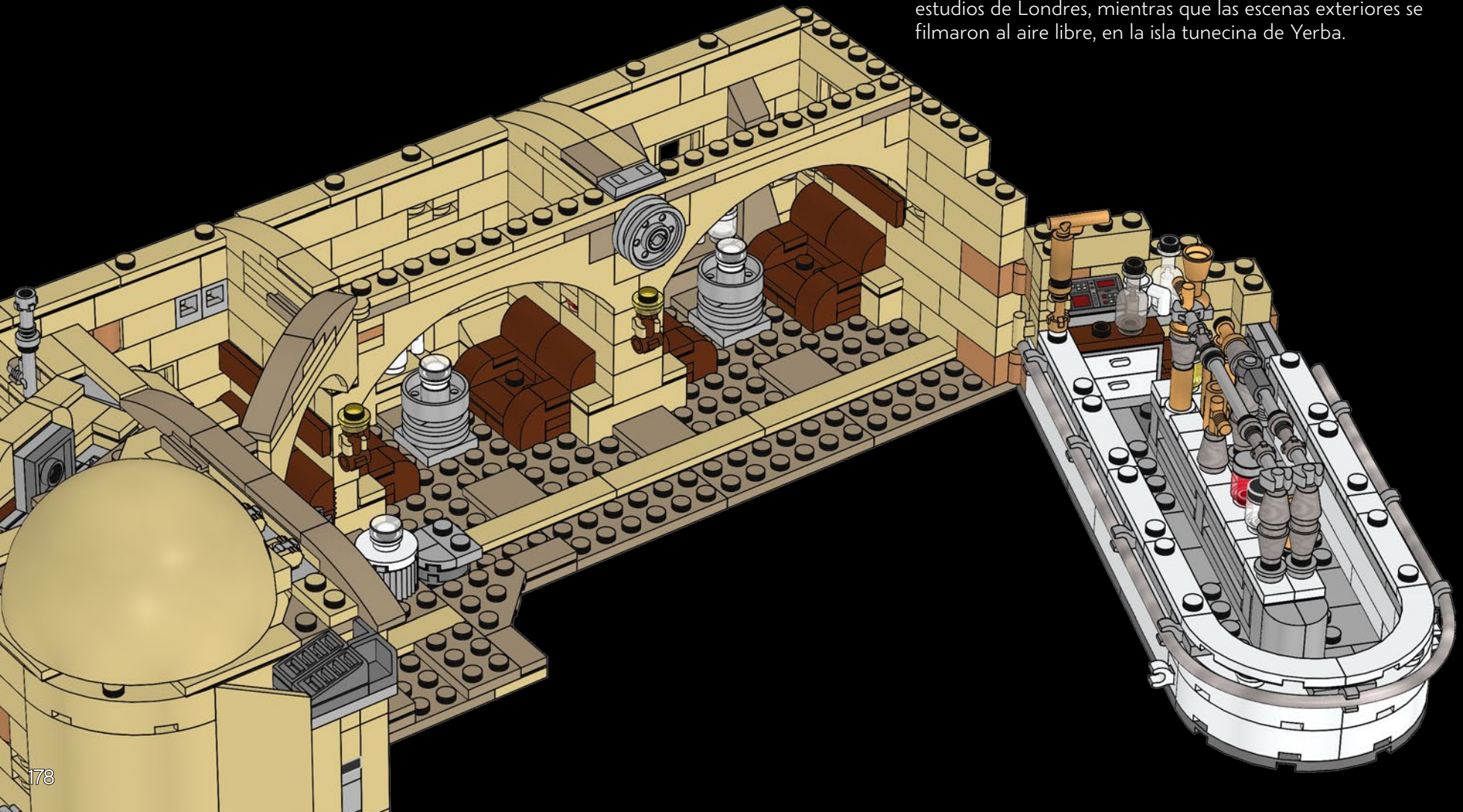

Interior shots of the Cantina were filmed at studios in London and exterior scenes were filmed on location on the Tunisian island of Djerba.

Les plans intérieurs de la cantina ont été filmés dans des studios de Londres, et les scènes extérieures ont été filmées sur l'île tunisienne de Djerba.

Las tomas en el interior de la cantina se grabaron en estudios de Londres, mientras que las escenas exteriores se filmaron al aire libre, en la isla tunecina de Yerba.

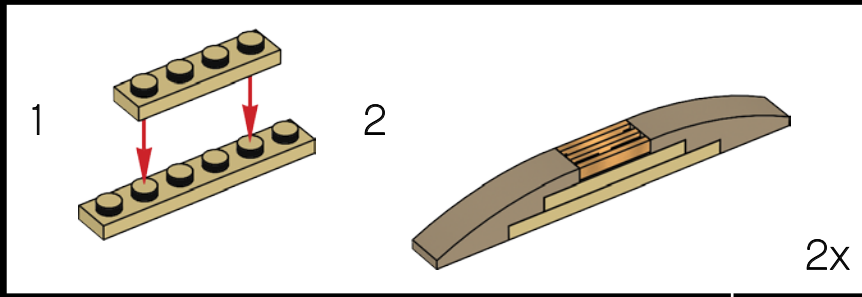
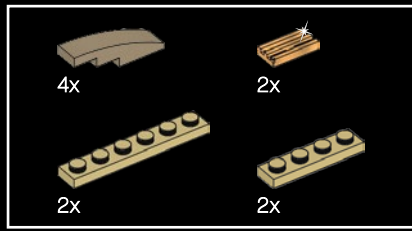

185

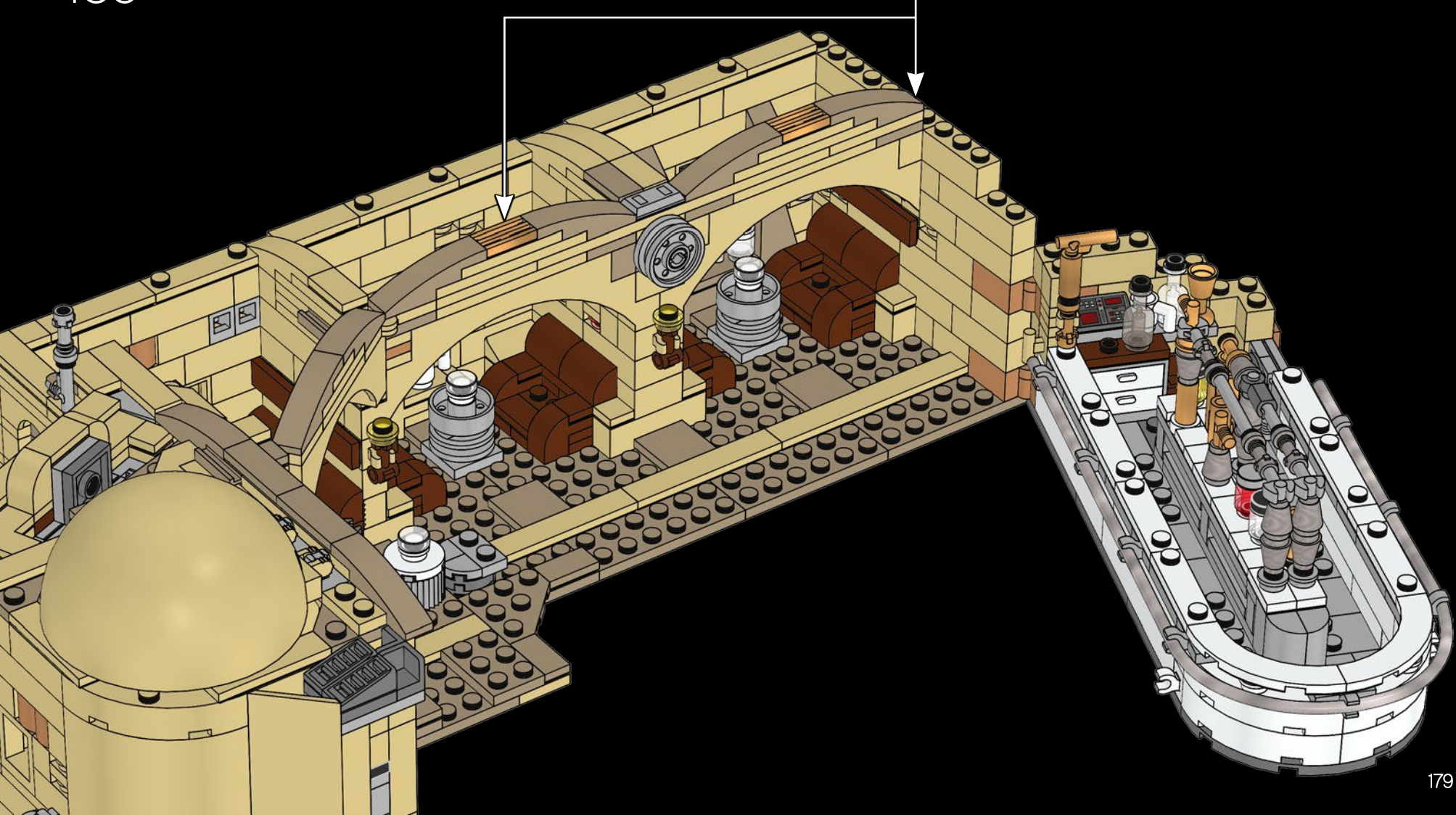

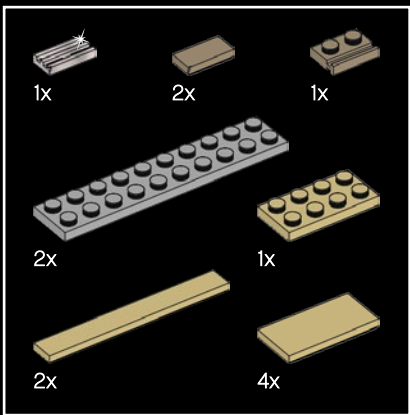

186

1

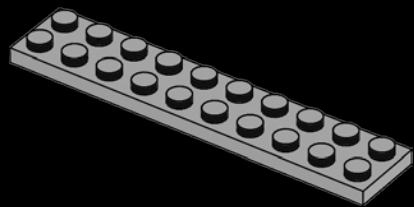

2

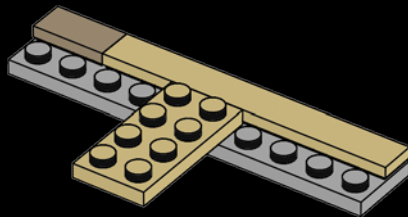

3

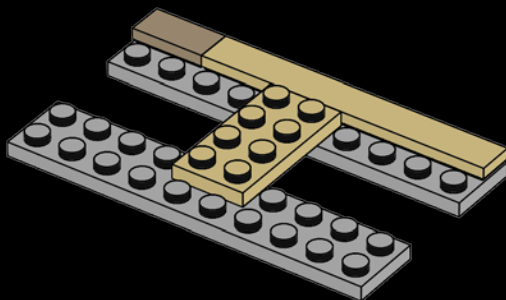

4

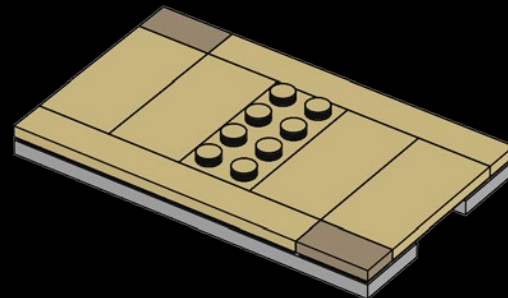

5

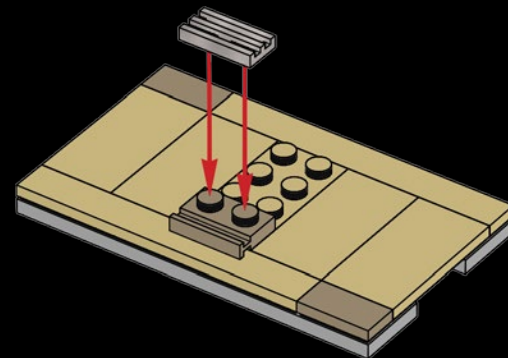

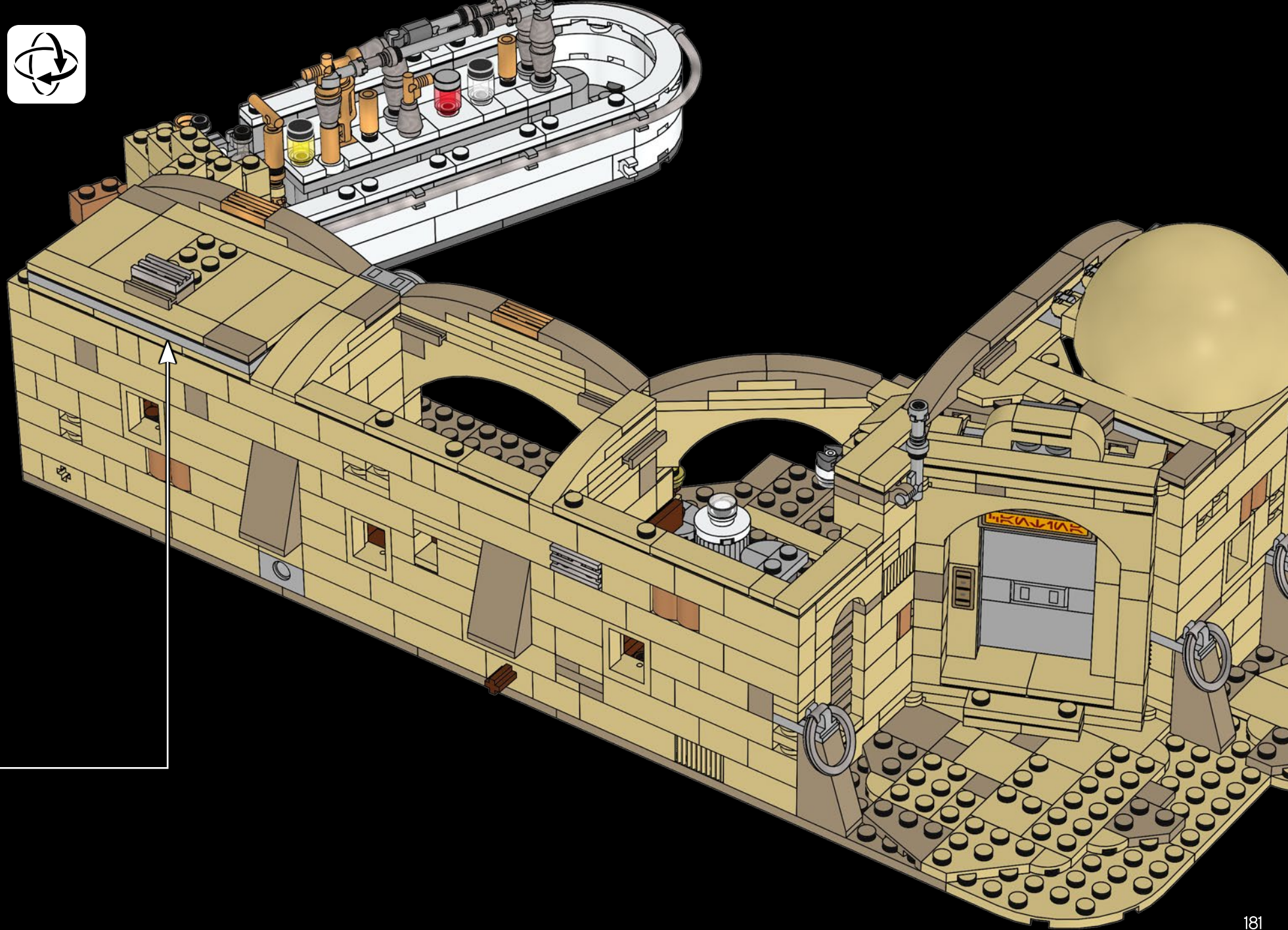

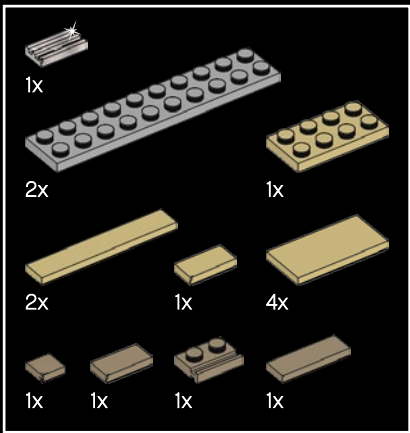

187

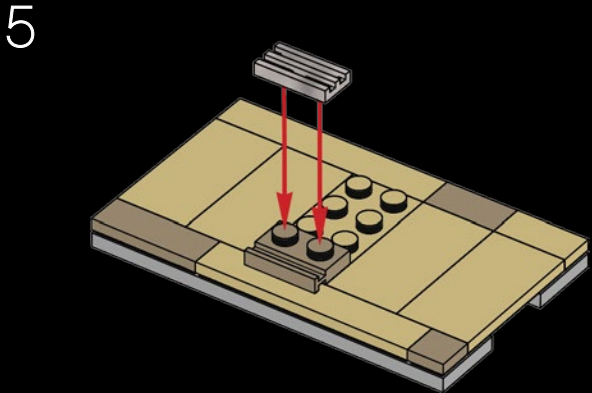
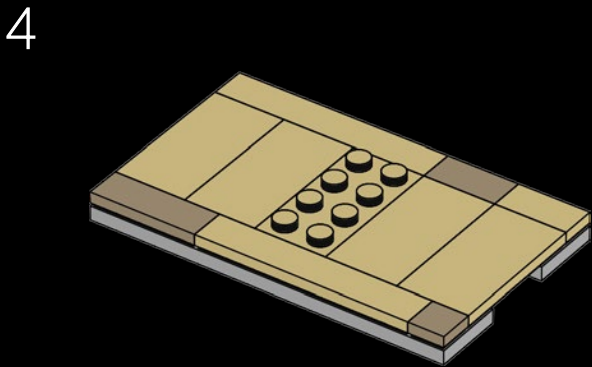
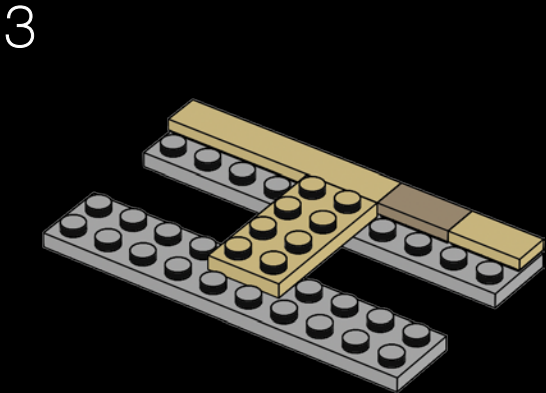
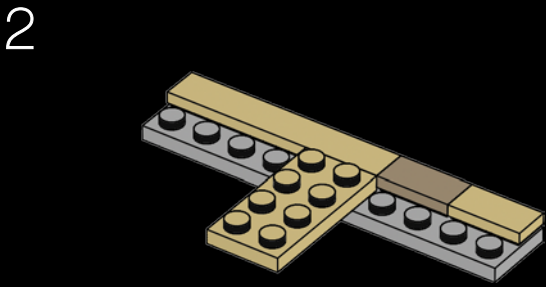
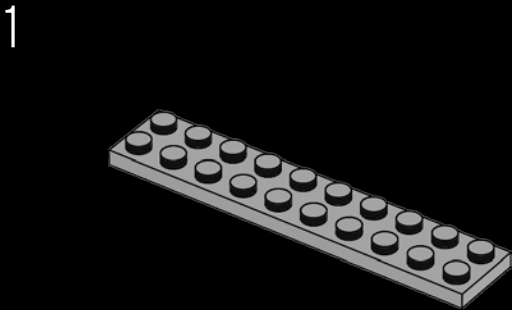

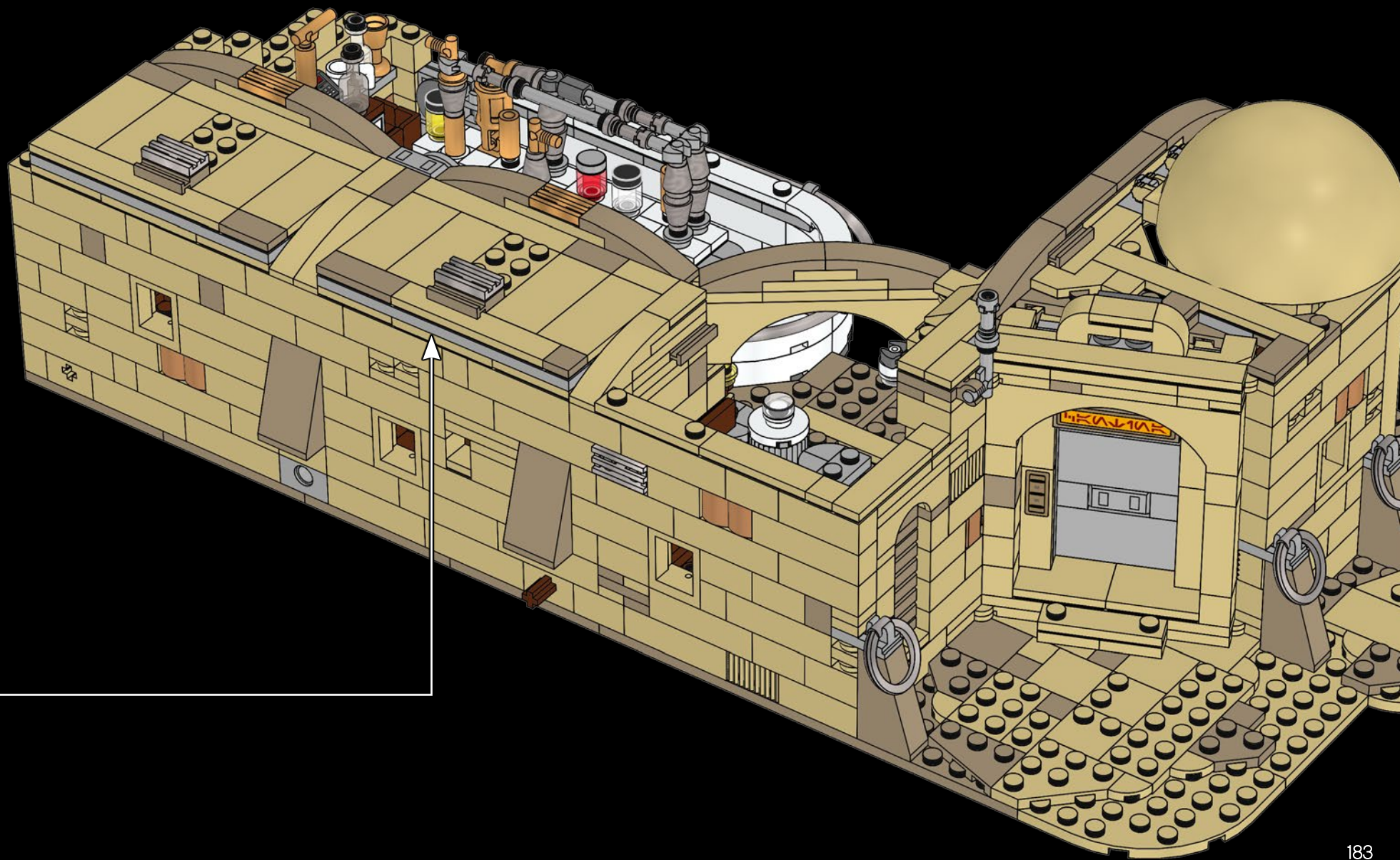

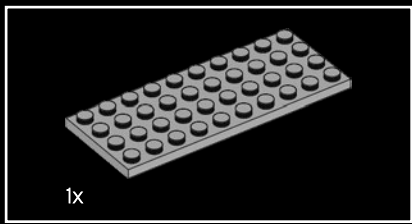

188

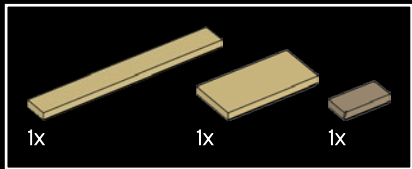
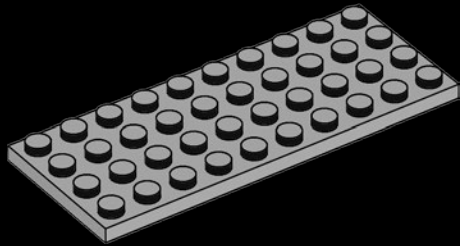

189

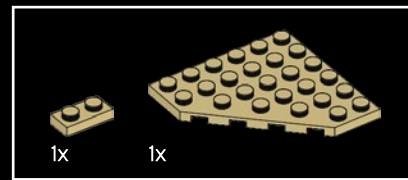
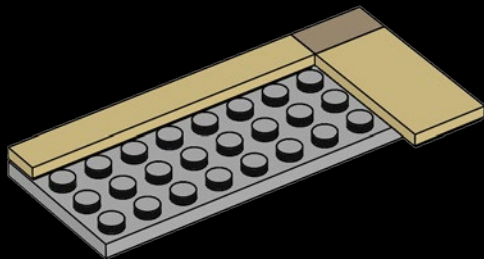

190

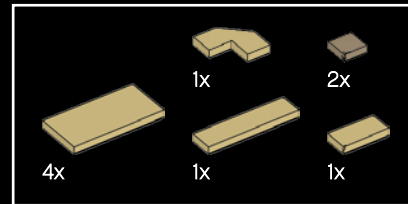
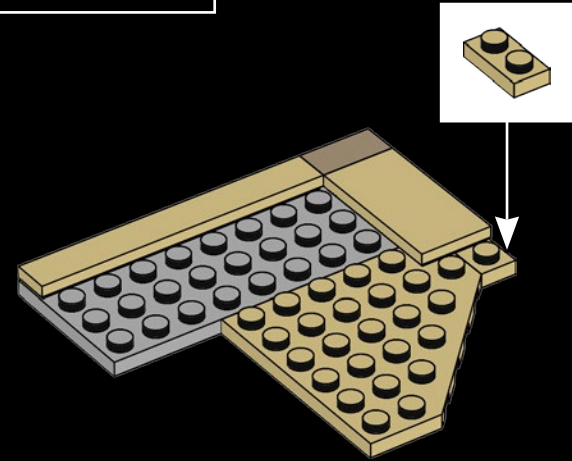

191

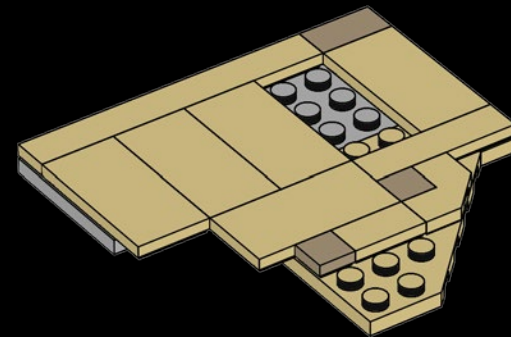



192

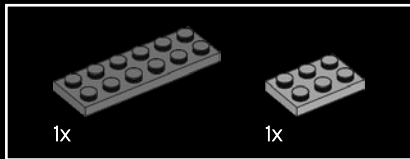
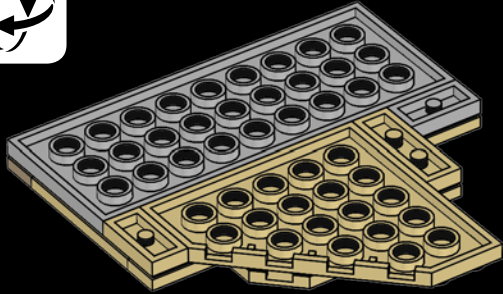

193

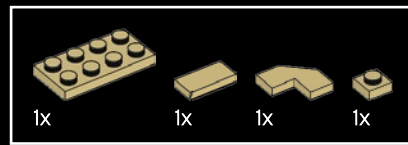
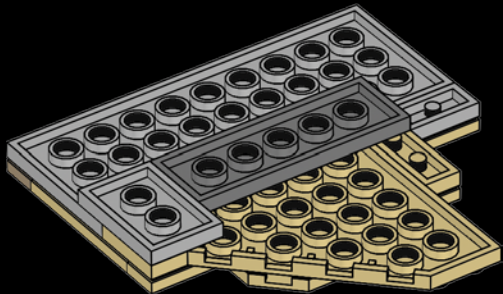

194

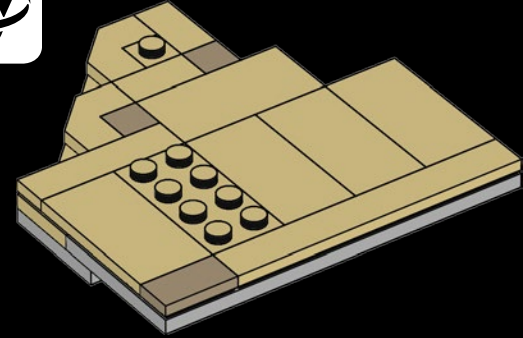

195

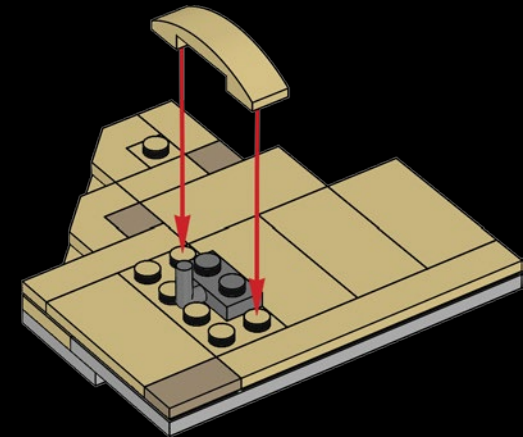

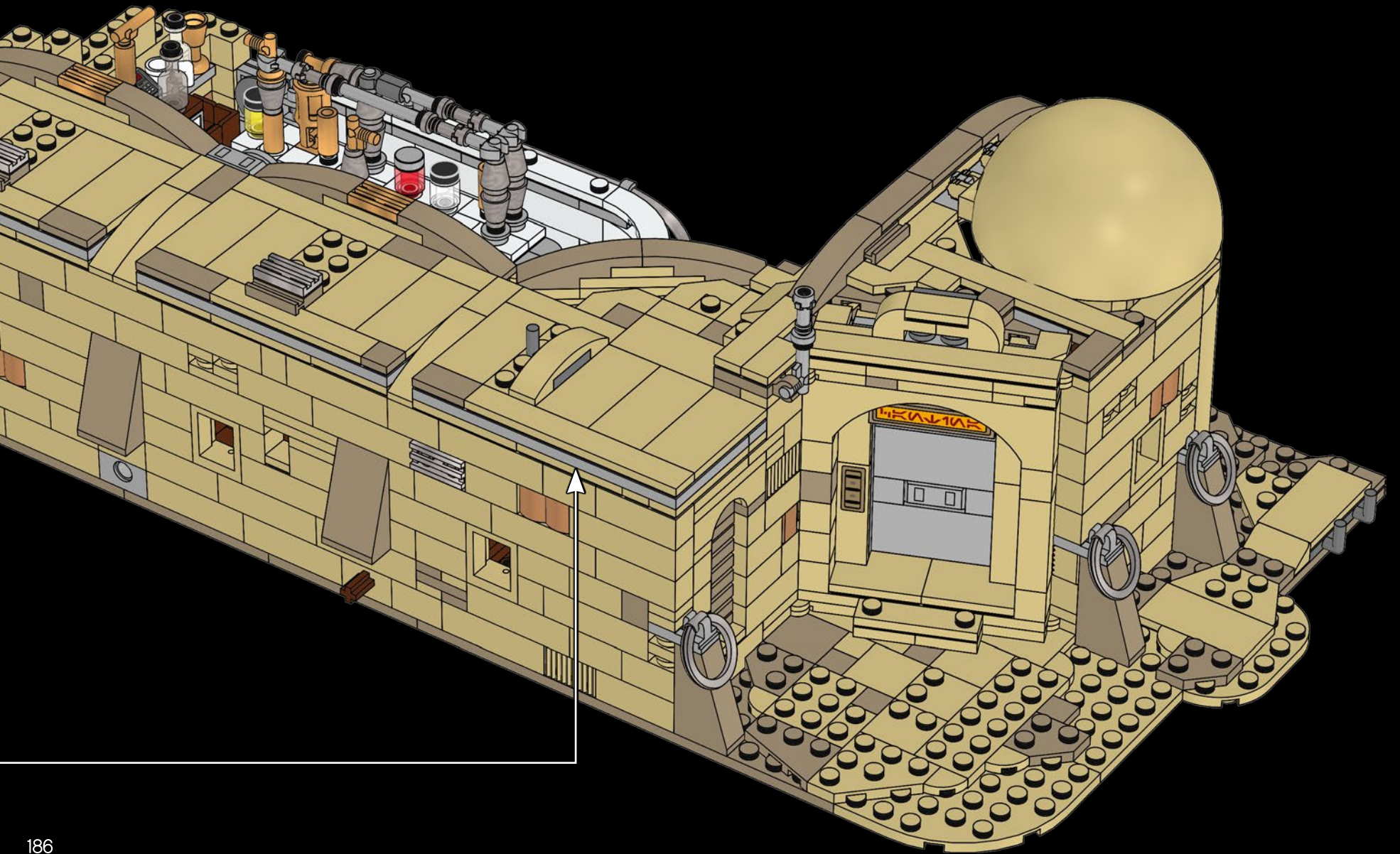

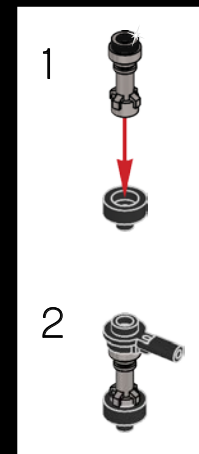
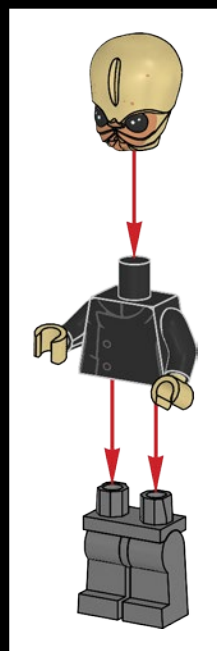
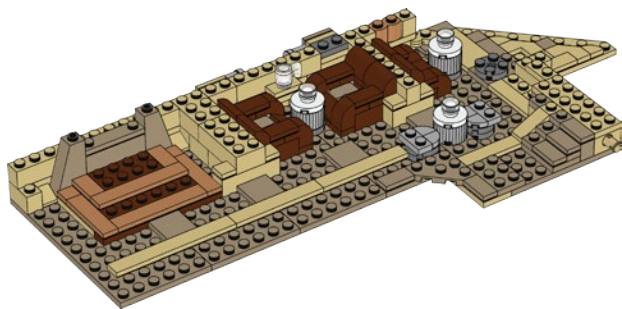
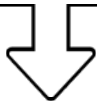

1

2



The official name of the all-Bith Cantina band is Figrin D'an and the Modal Nodes. Figrin D'an is the leader, and other members include Nalan Cheel, Doikk Na'ts, Tedn Dahai, Tech M'or, Ickabel G'ont, and Sun'il Ei'de. Their biggest hit is "Mad About Me" when translated to basic.

Le nom officiel du groupe de musique entièrement Bith de la cantina est Figrin D'an et les Modal Nodes. Le groupe est dirigé par Figrin D'an et comprend également Nalan Cheel, Doikk Na'ts, Tedn Dahai, Tech M'or, Ickabel G'ont et Sun'il Ei'de. Le nom de leur plus grand succès est « Mad About Me » lorsqu'il est traduit en basic.

El nombre oficial de la banda de la cantina, compuesta íntegramente por músicos Bith, es Figrin D'an y los Modal Nodes. Figrin D'an es el líder; los demás miembros son Nalan Cheel, Doikk Na'ts, Tedn Dahai, Tech M'or, Ickabel G'ont y Sun'il Ei'de. Su mayor éxito es *Mad about me* (traducido al inglés básico).

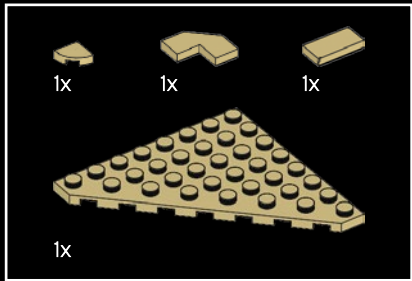
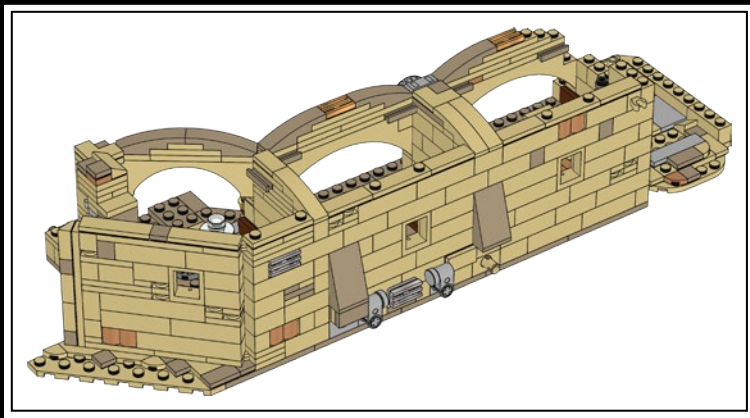

197

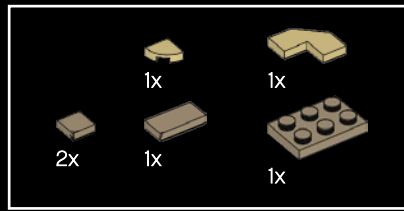
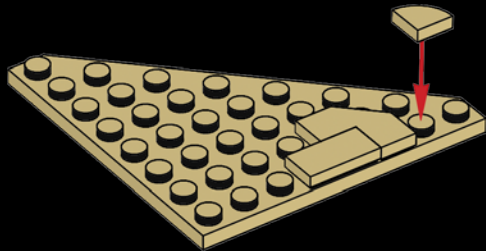

198

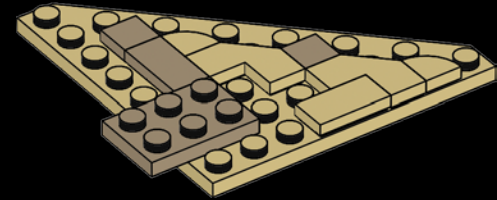

199

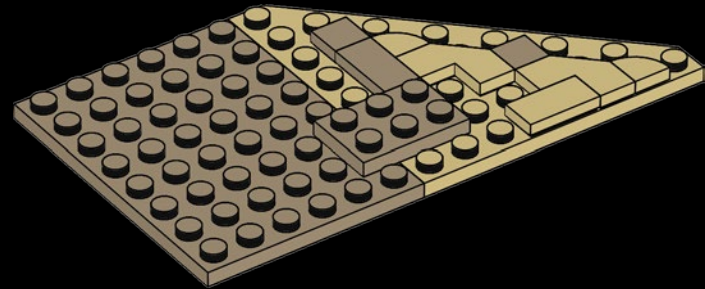

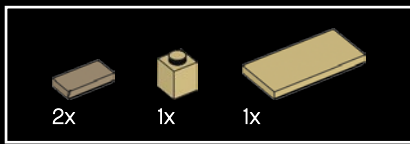

200

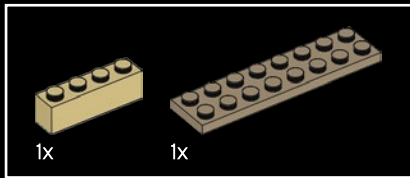
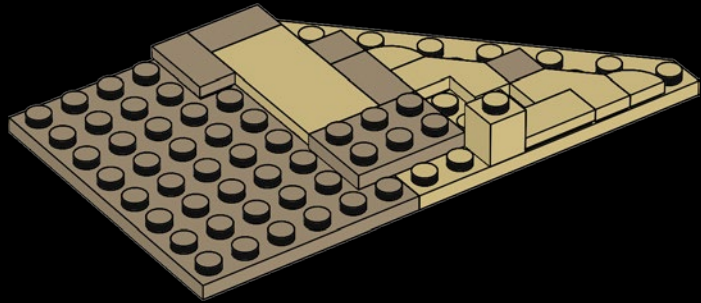

201

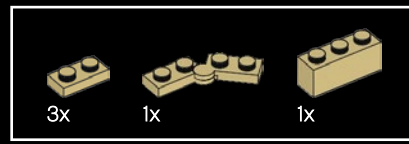
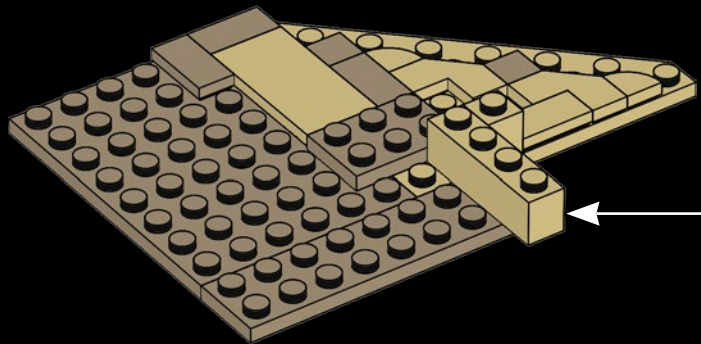
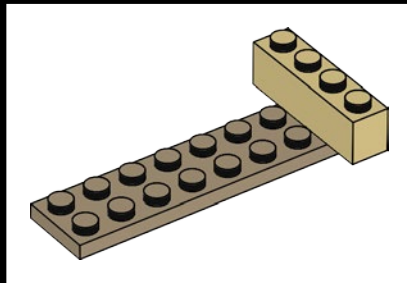

202

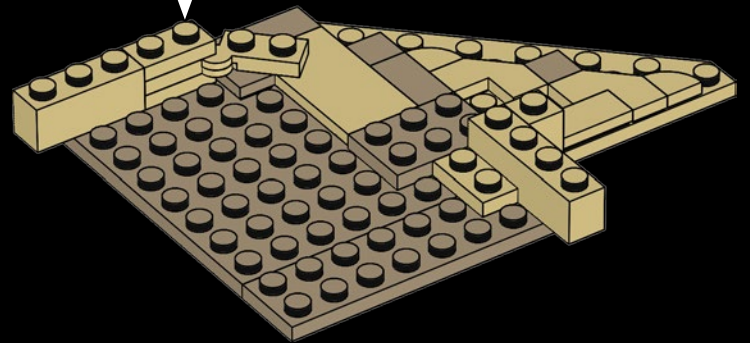
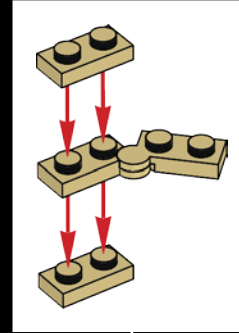

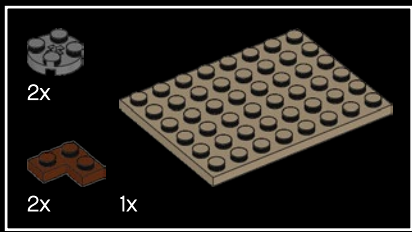

203

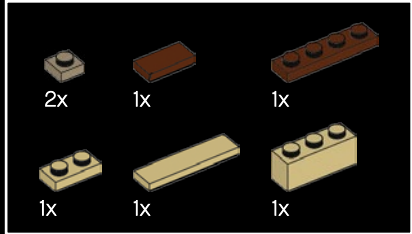
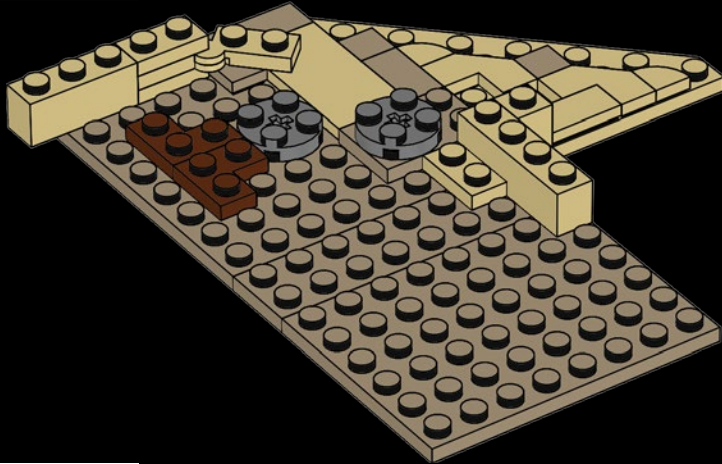

204

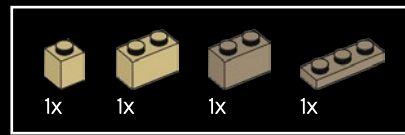
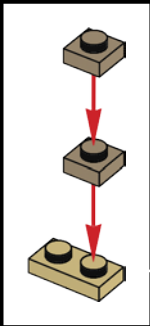
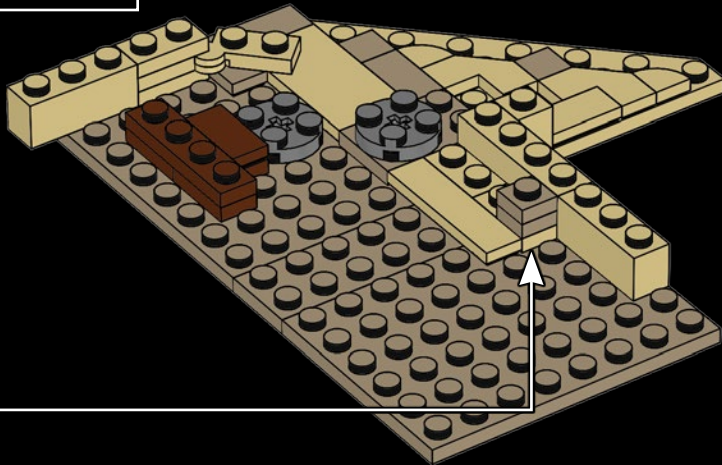

205

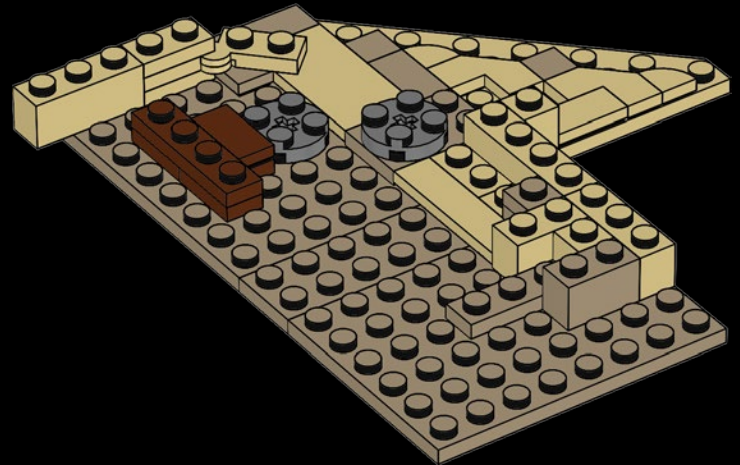

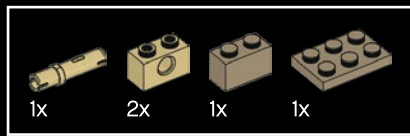

206

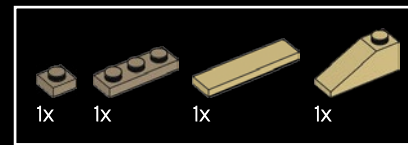
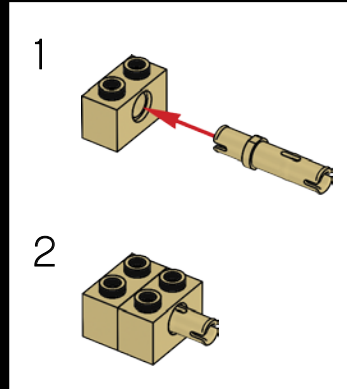

207

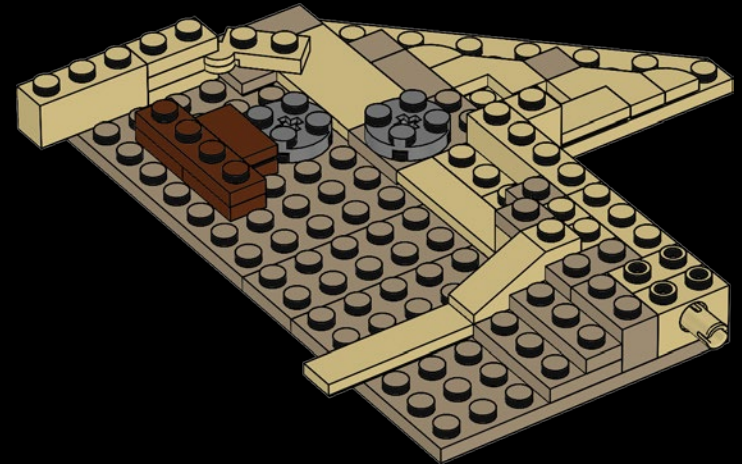

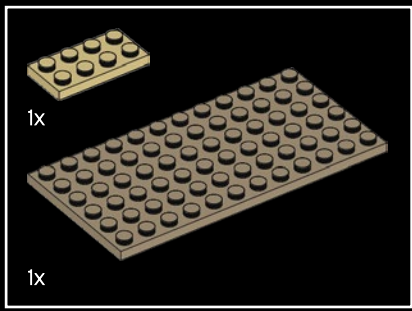

208

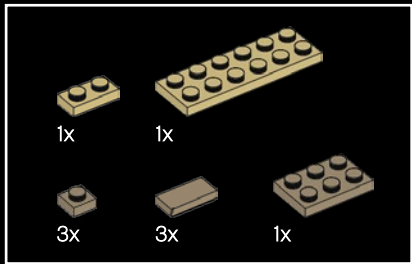
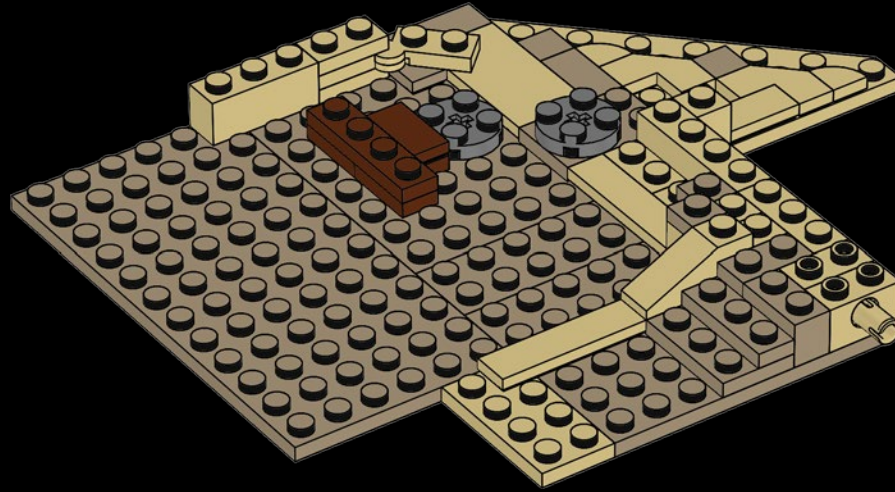

209

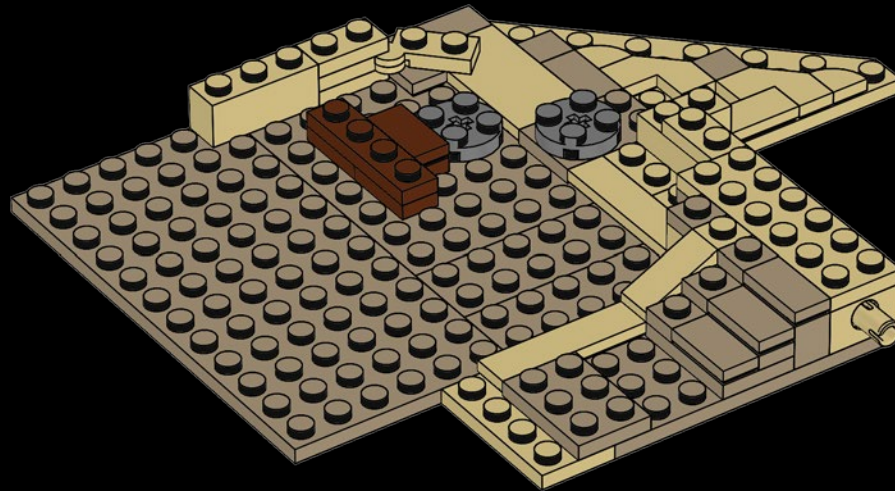

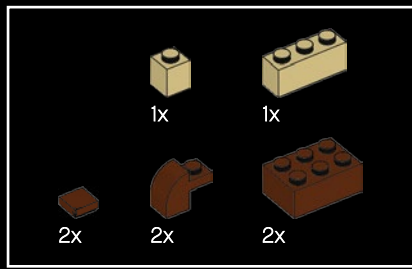

210

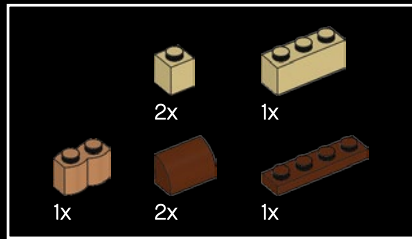
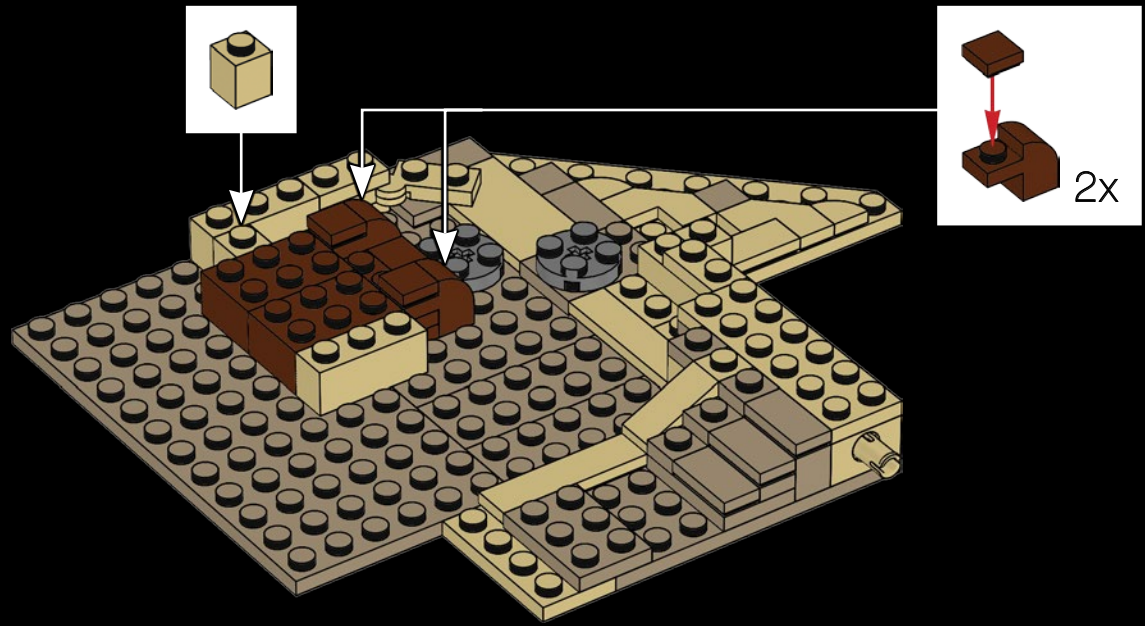

211

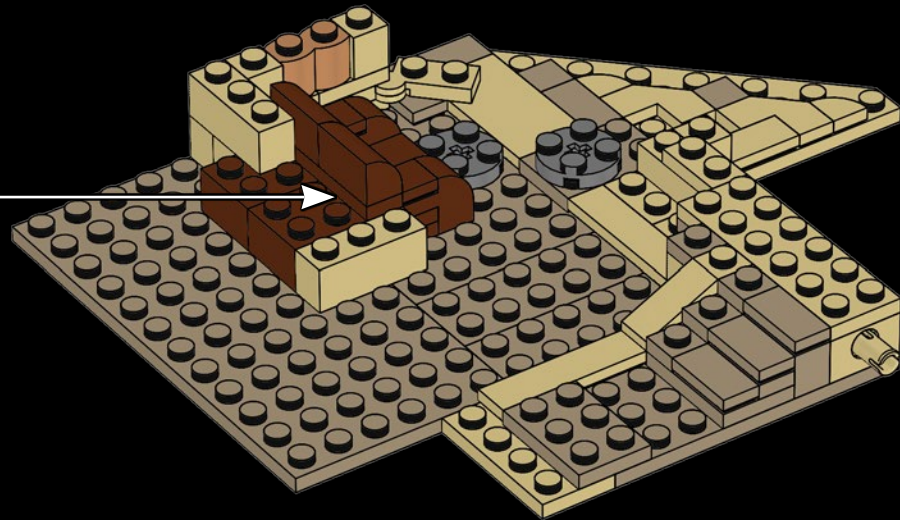
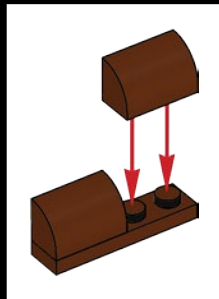

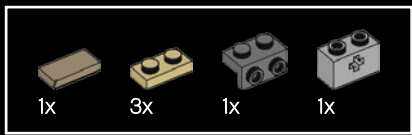

212

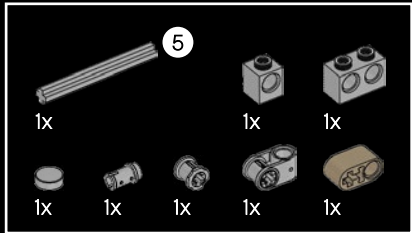
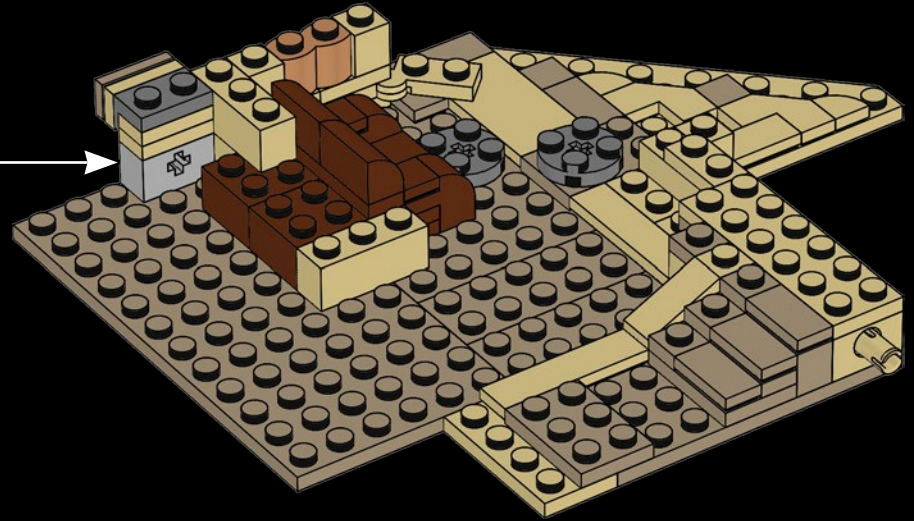
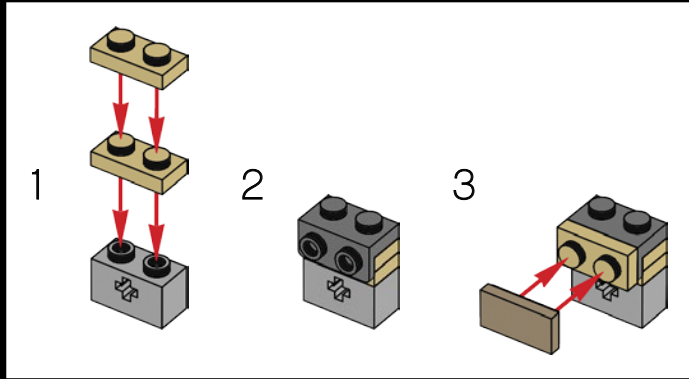

213

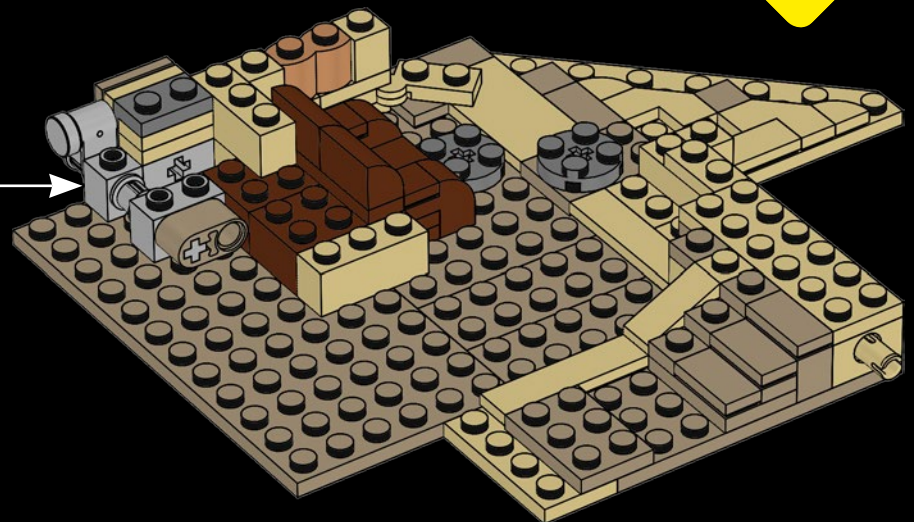
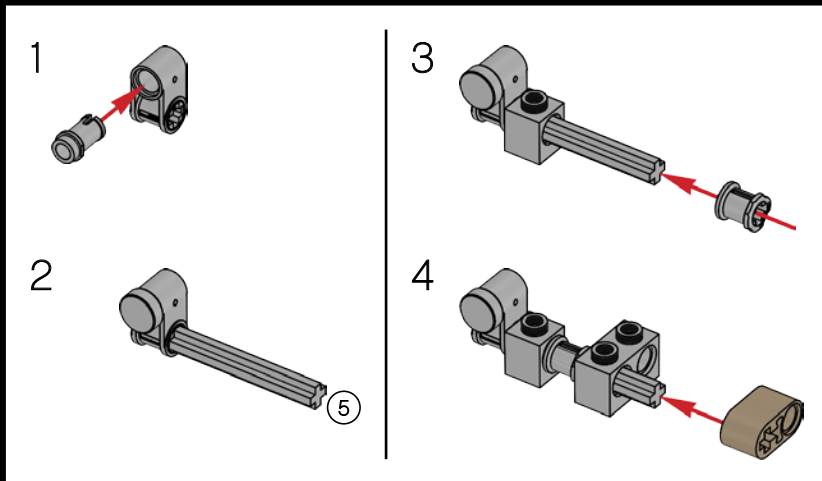

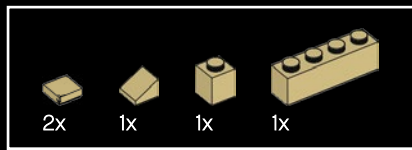

214

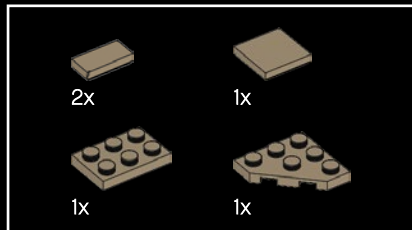
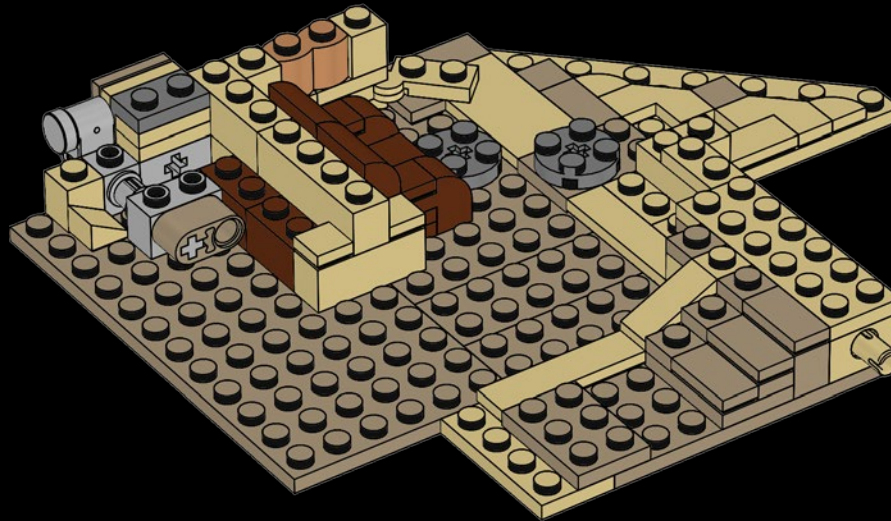

215

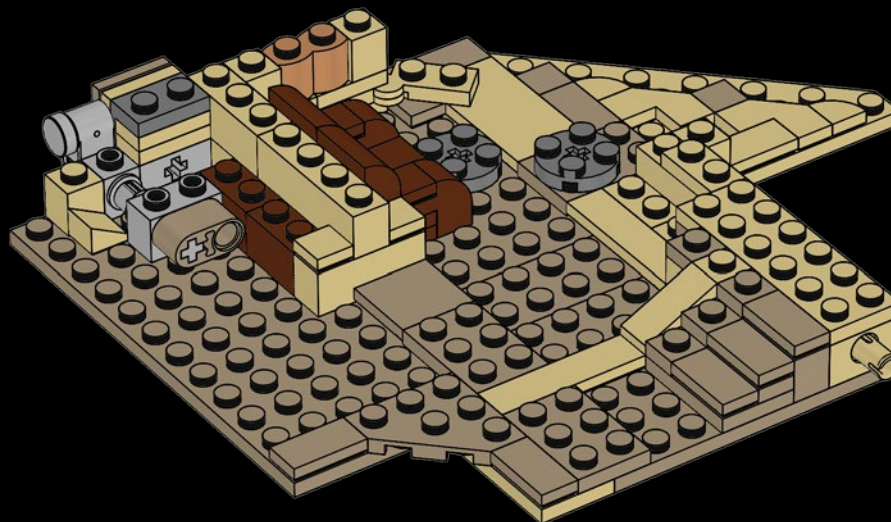

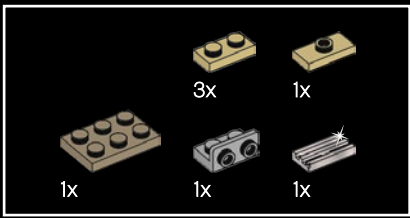

216

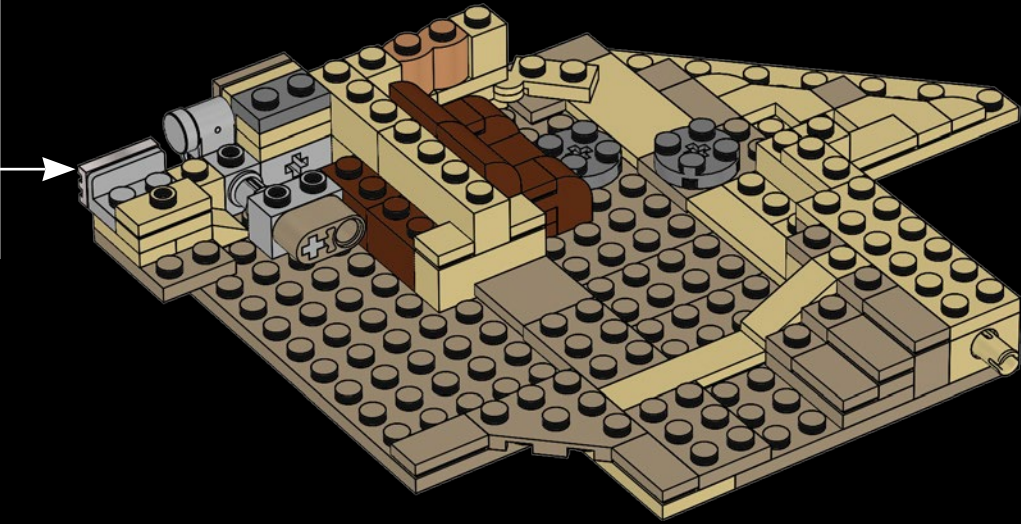
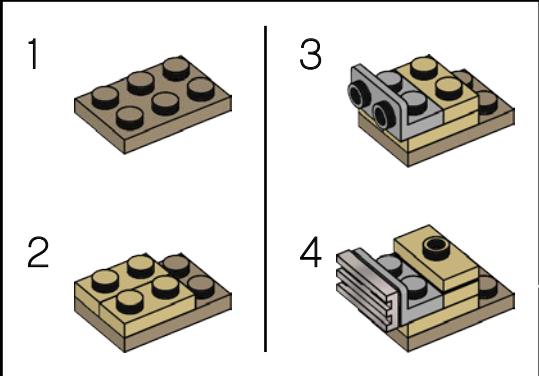

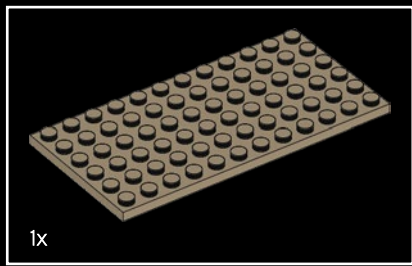

217

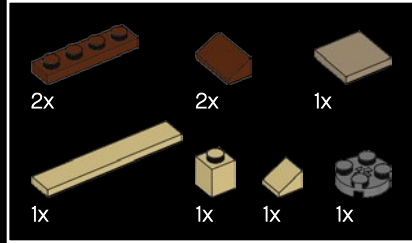
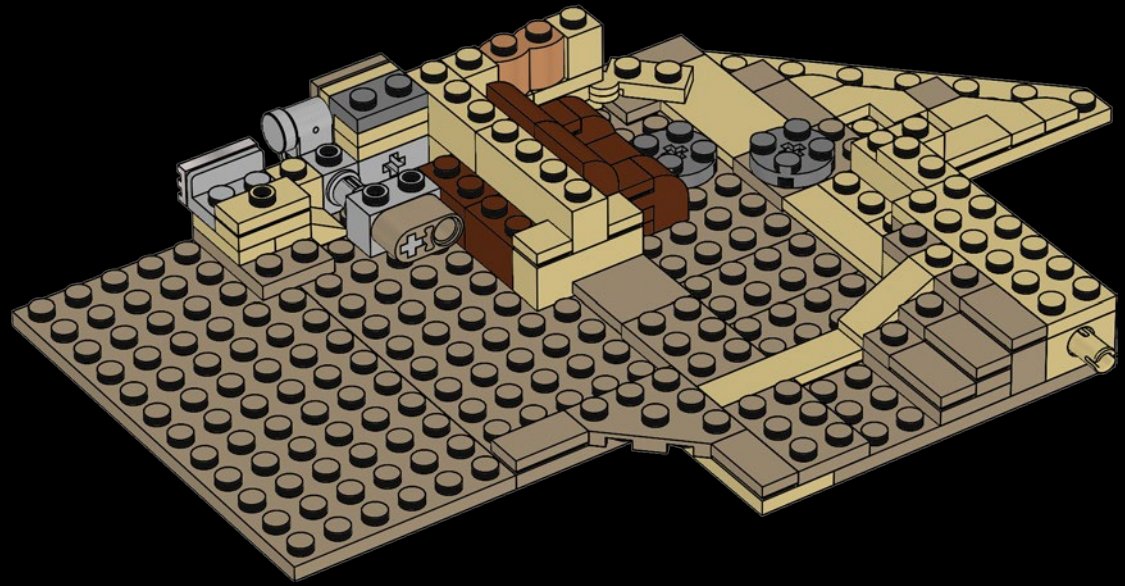

218

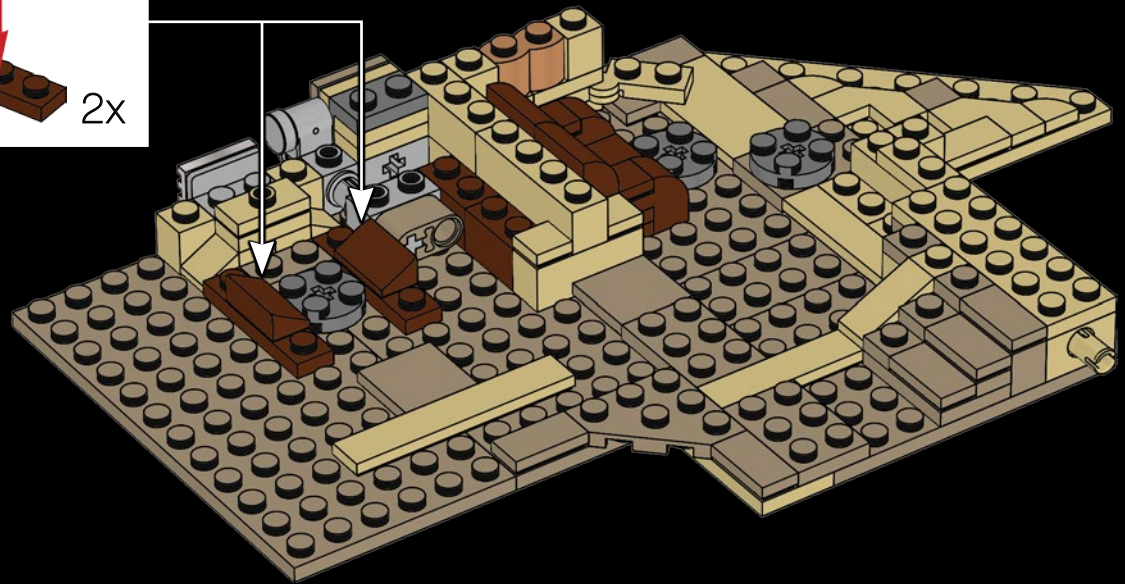
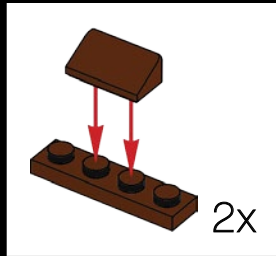

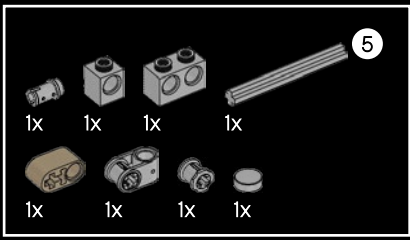

219

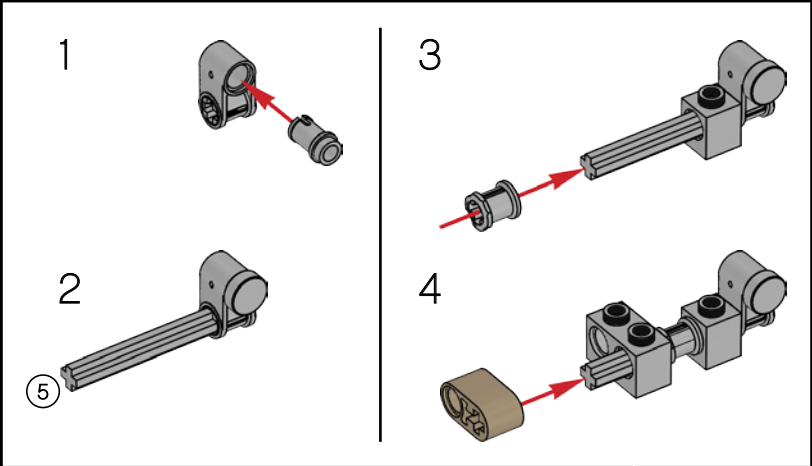



220

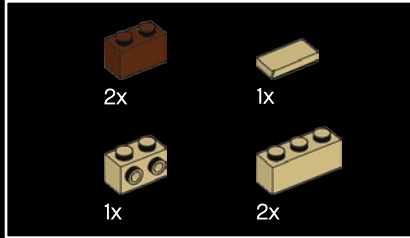
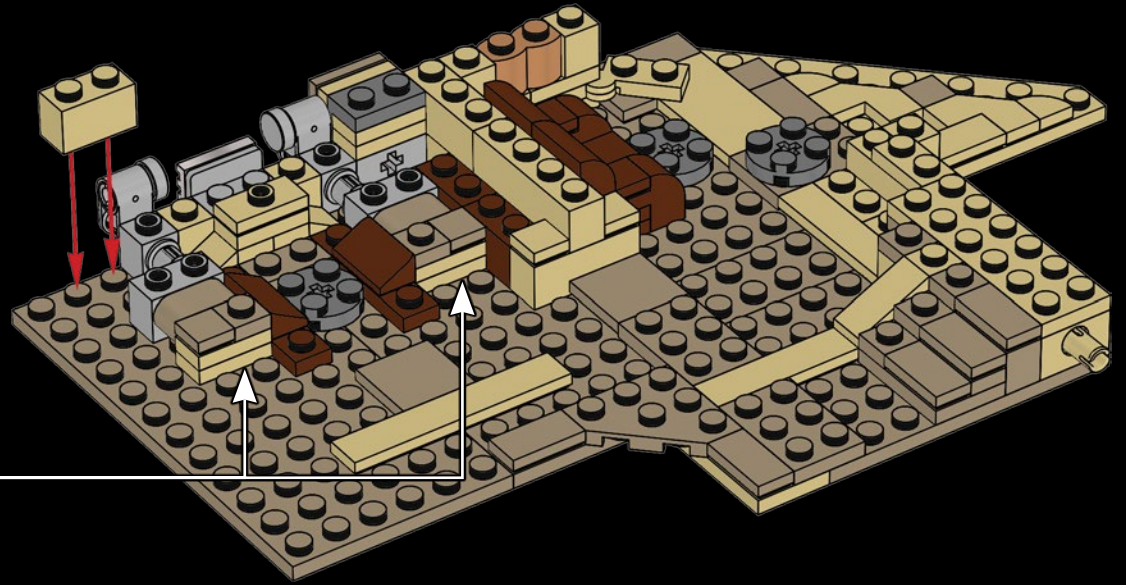
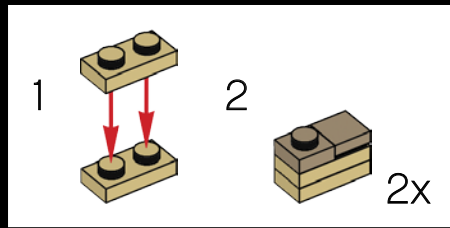

221

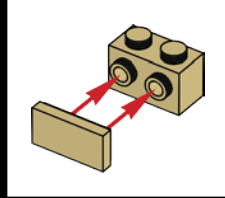

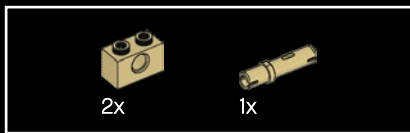

222

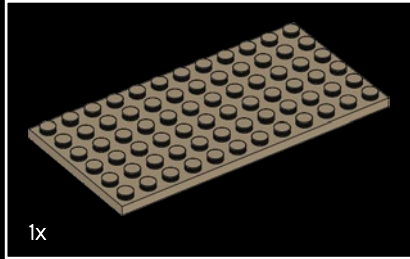
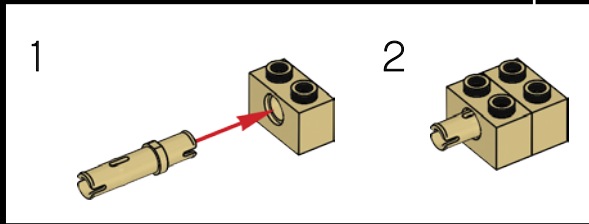
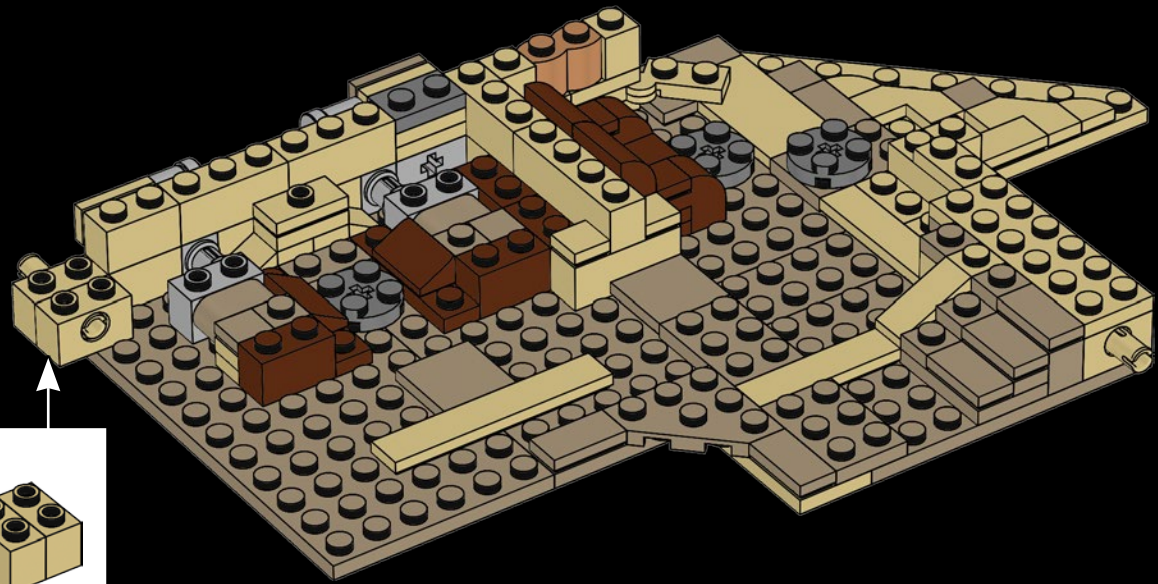

223



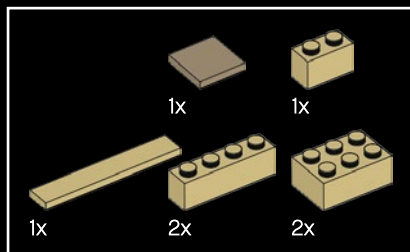

224

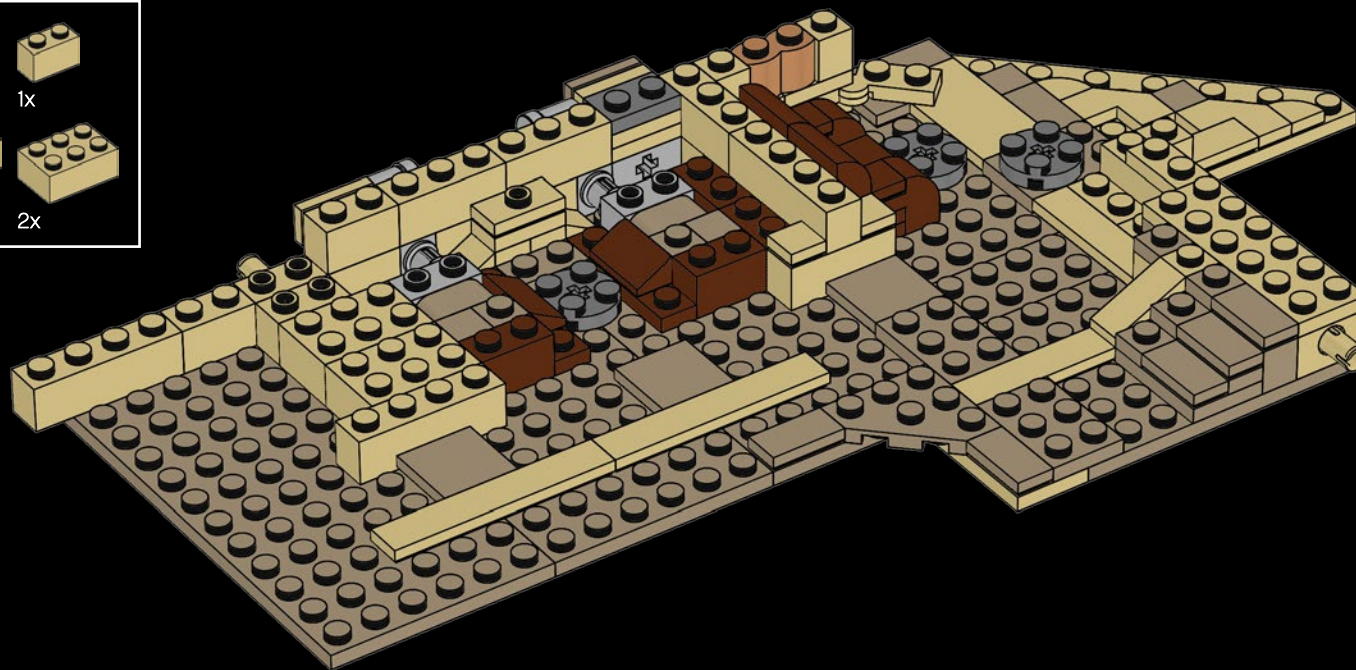

225

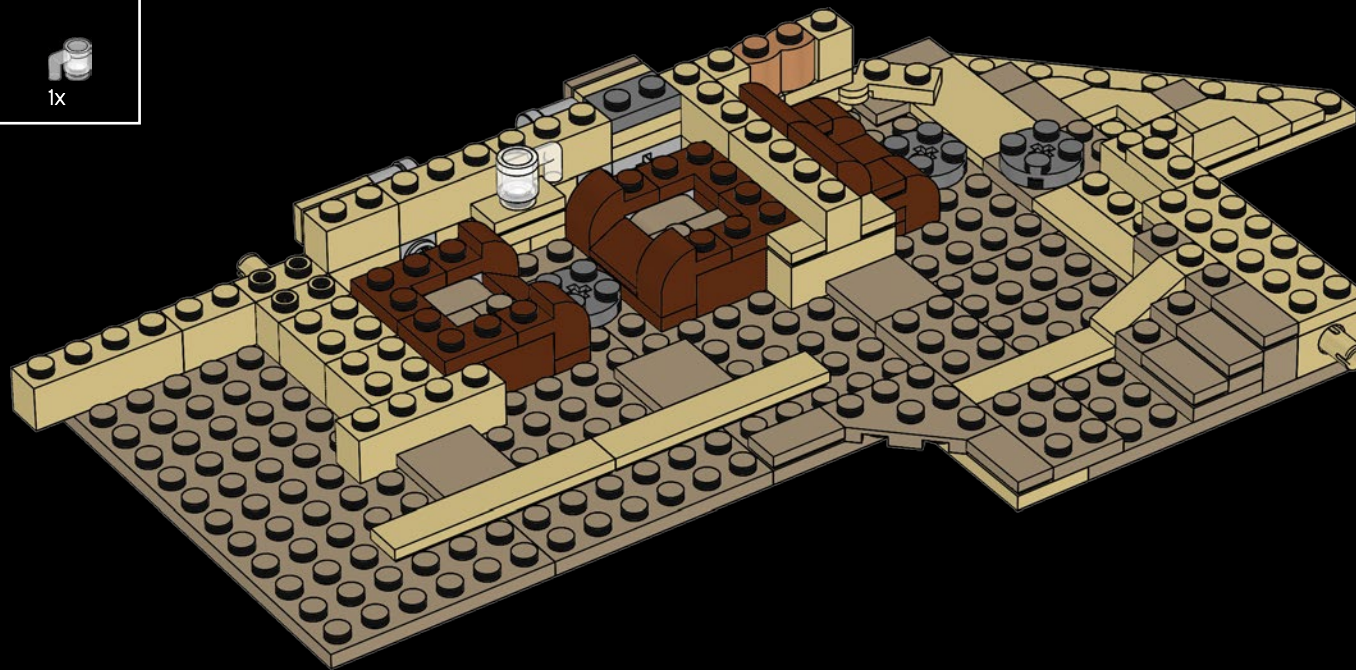

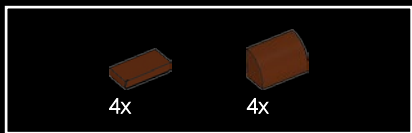

226

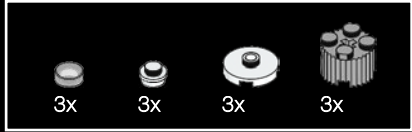
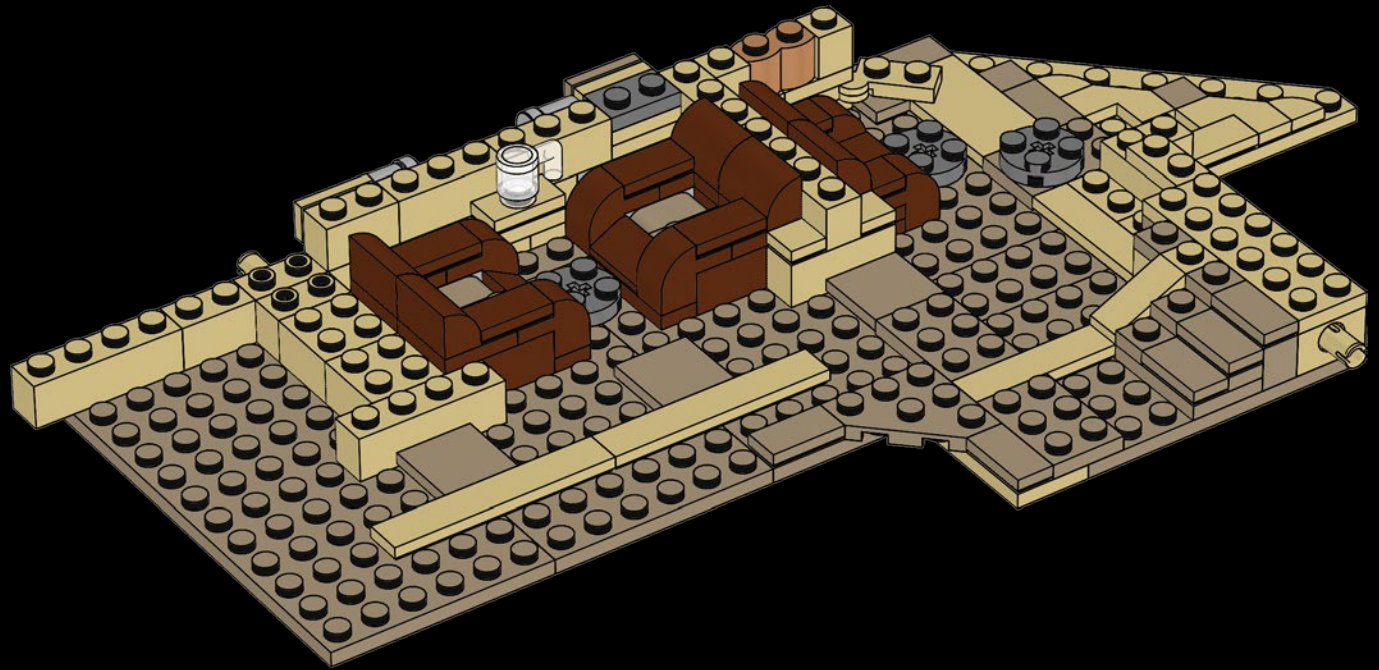

227

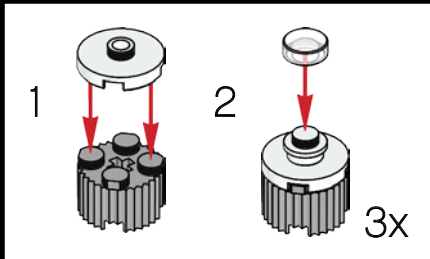
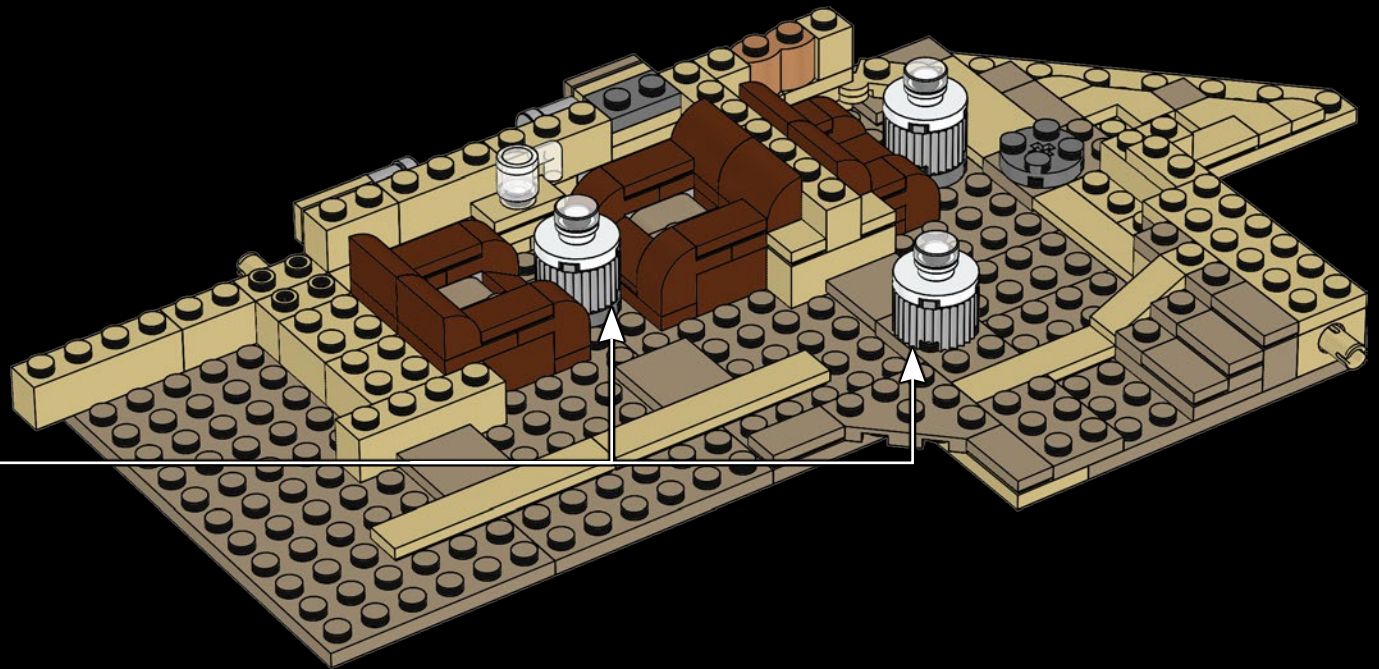



228

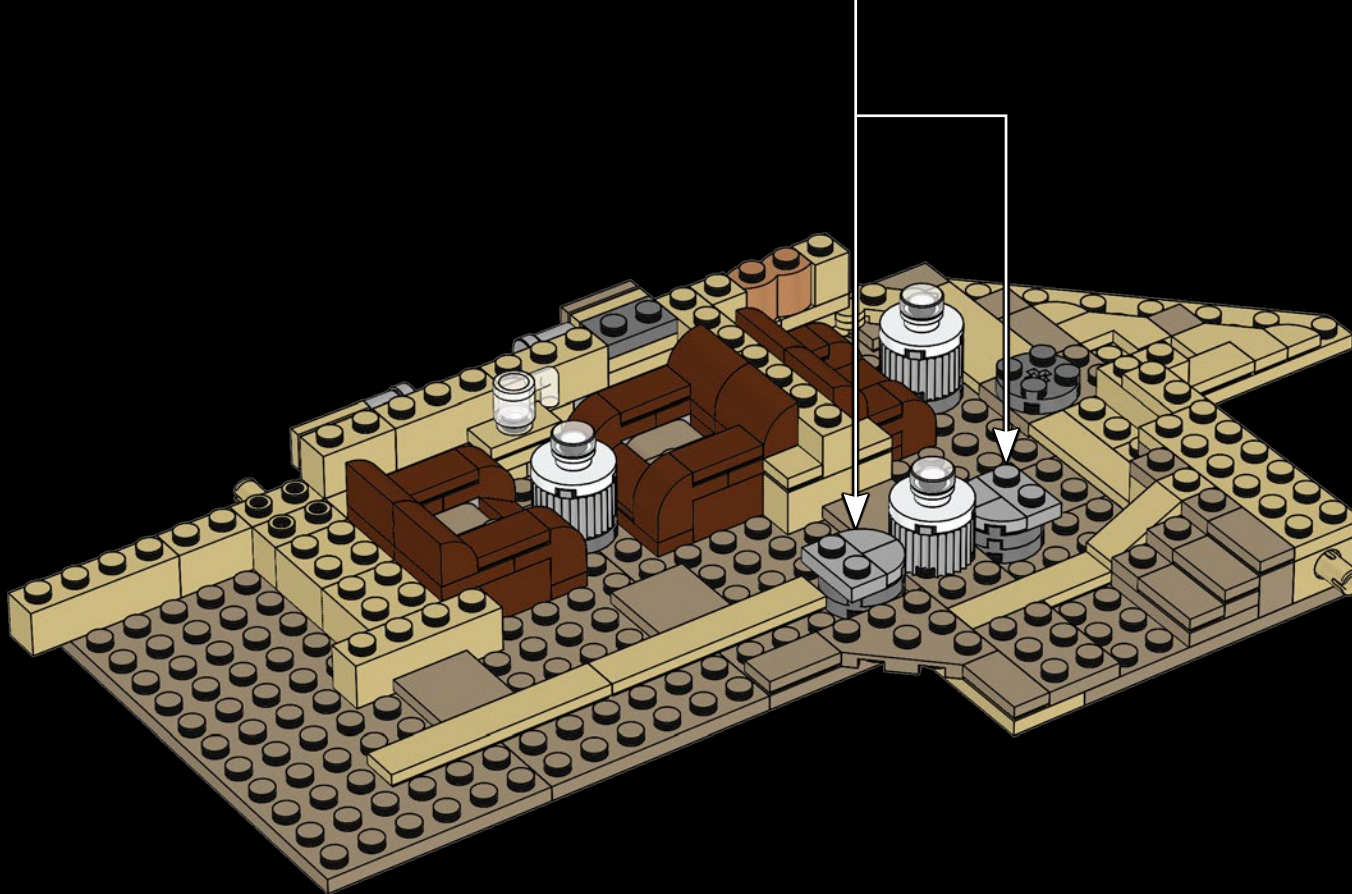
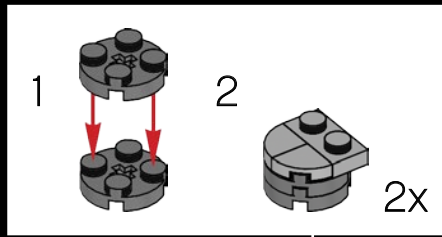

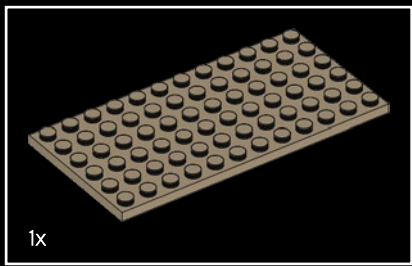

1x

229

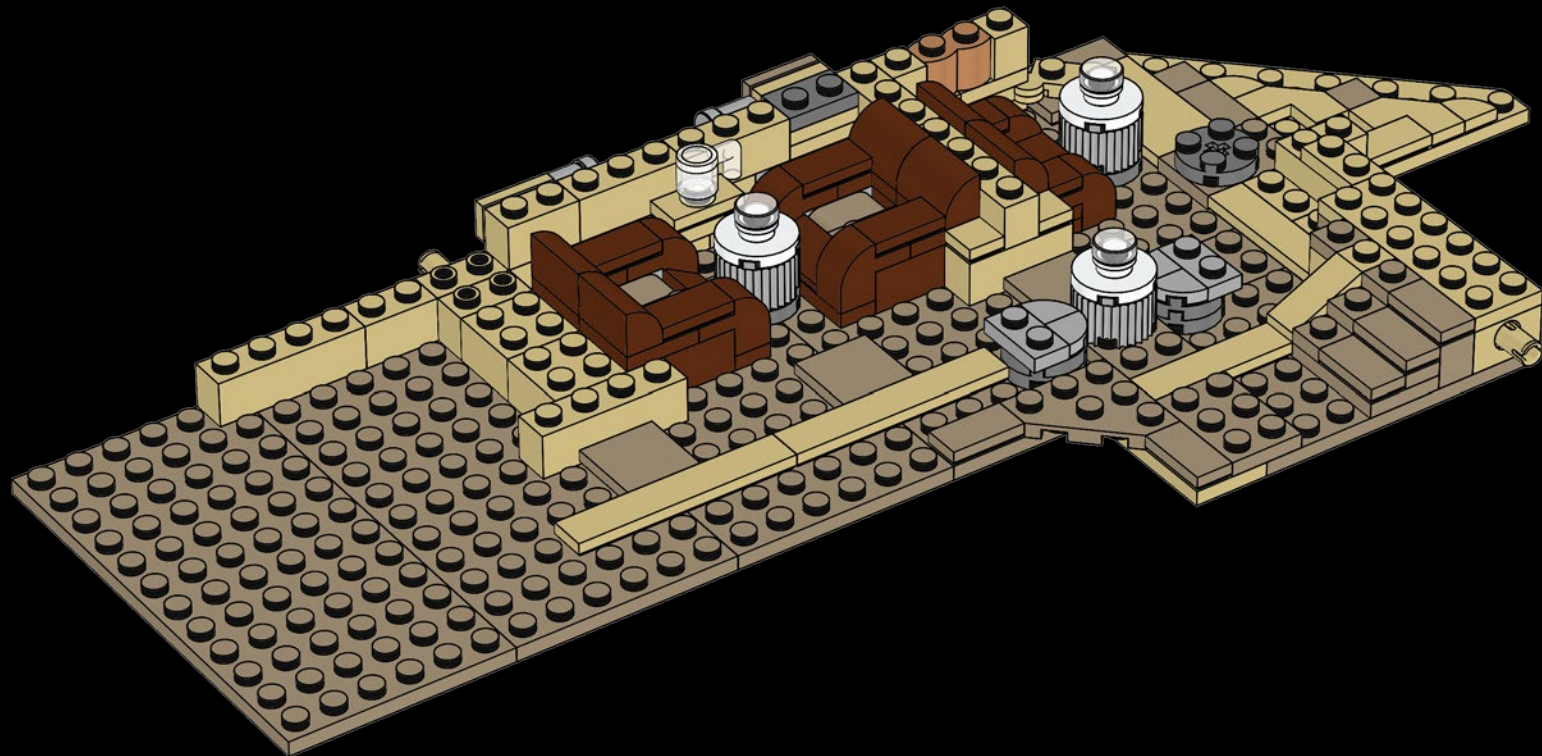

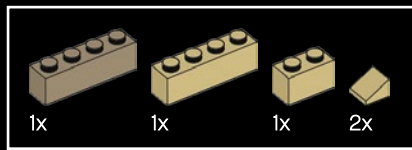

230

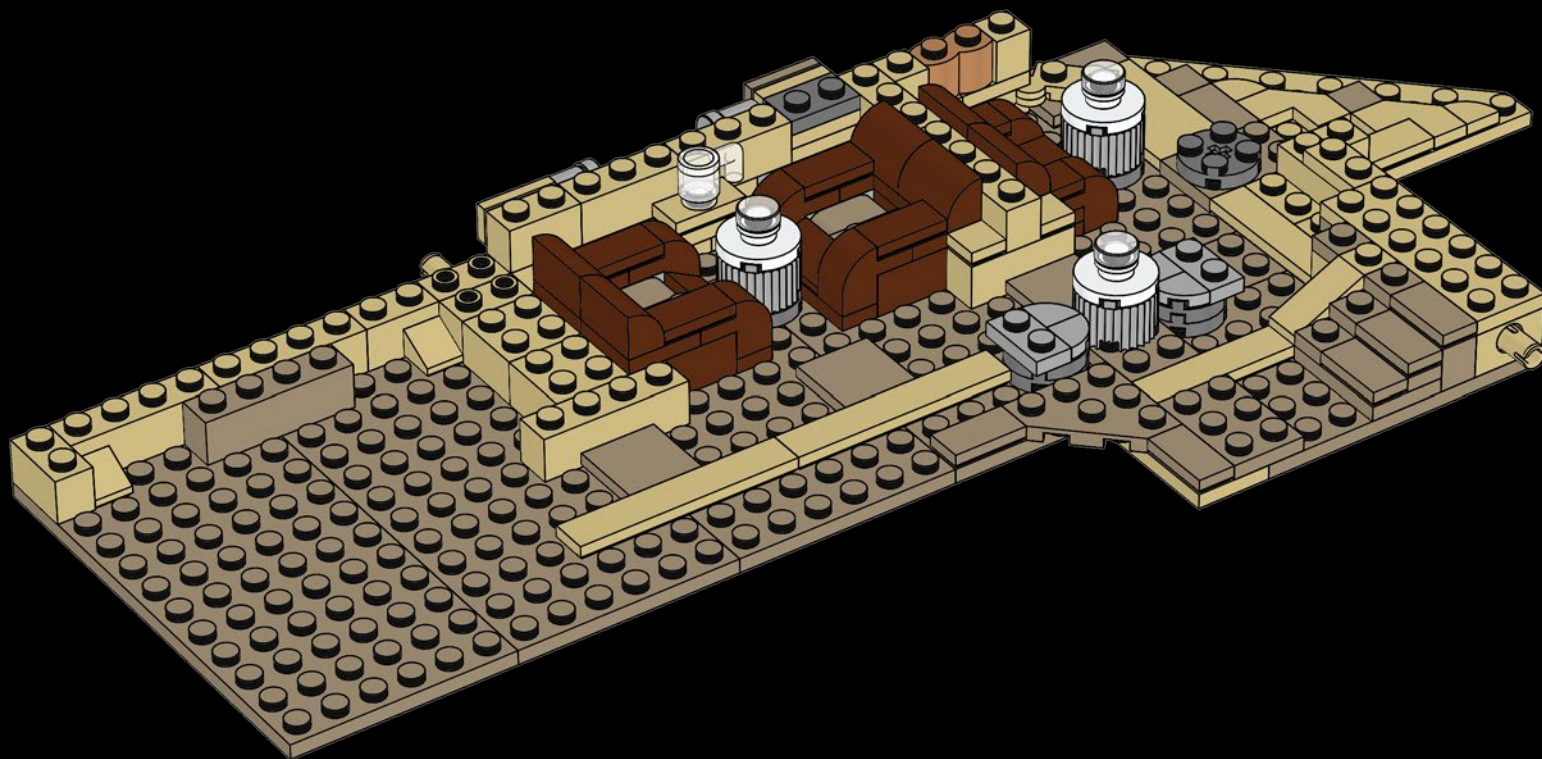

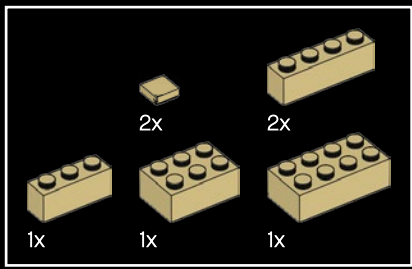

231

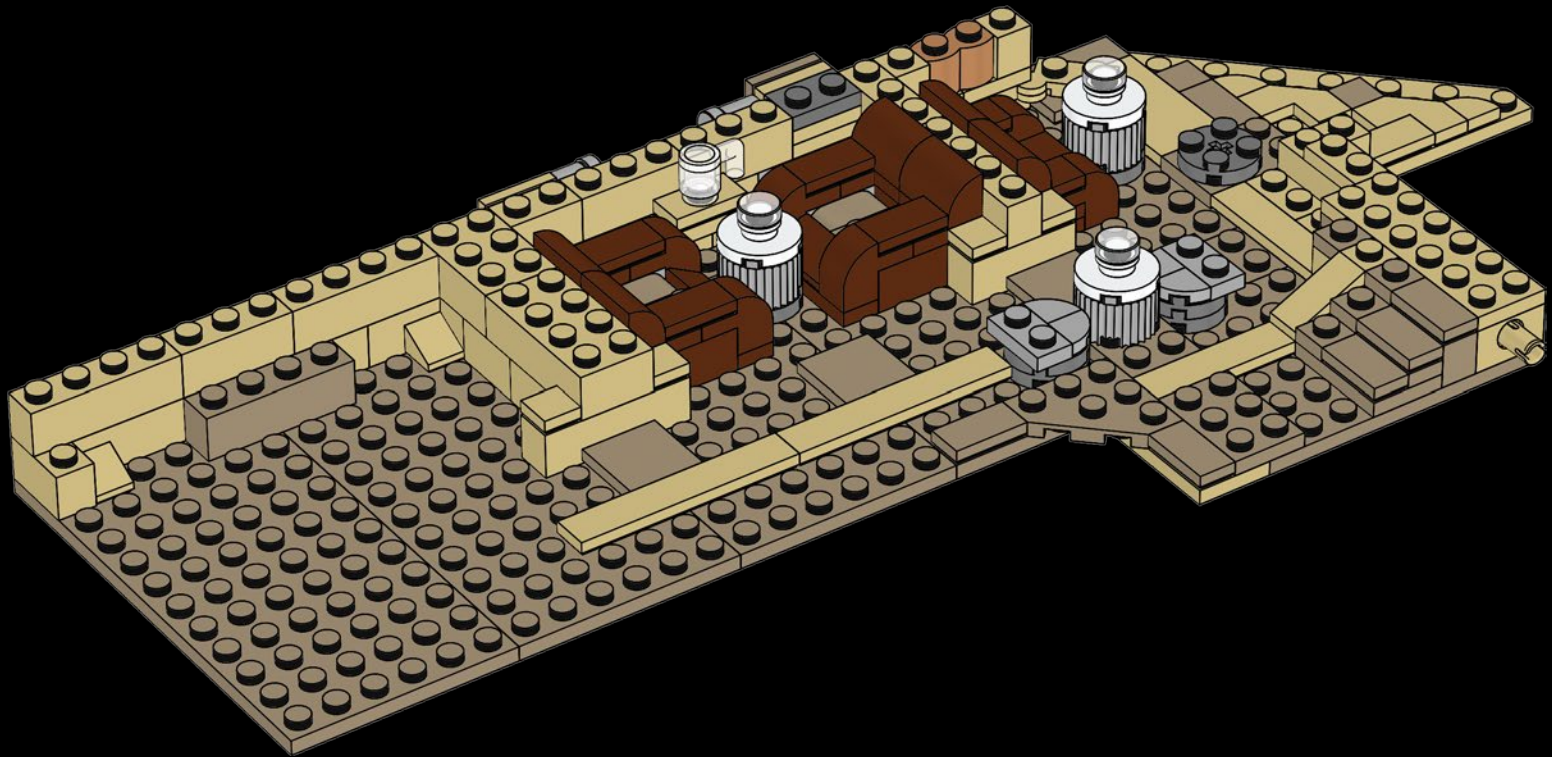

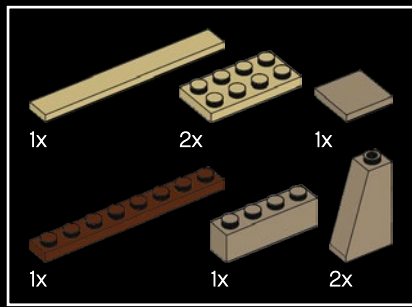

232

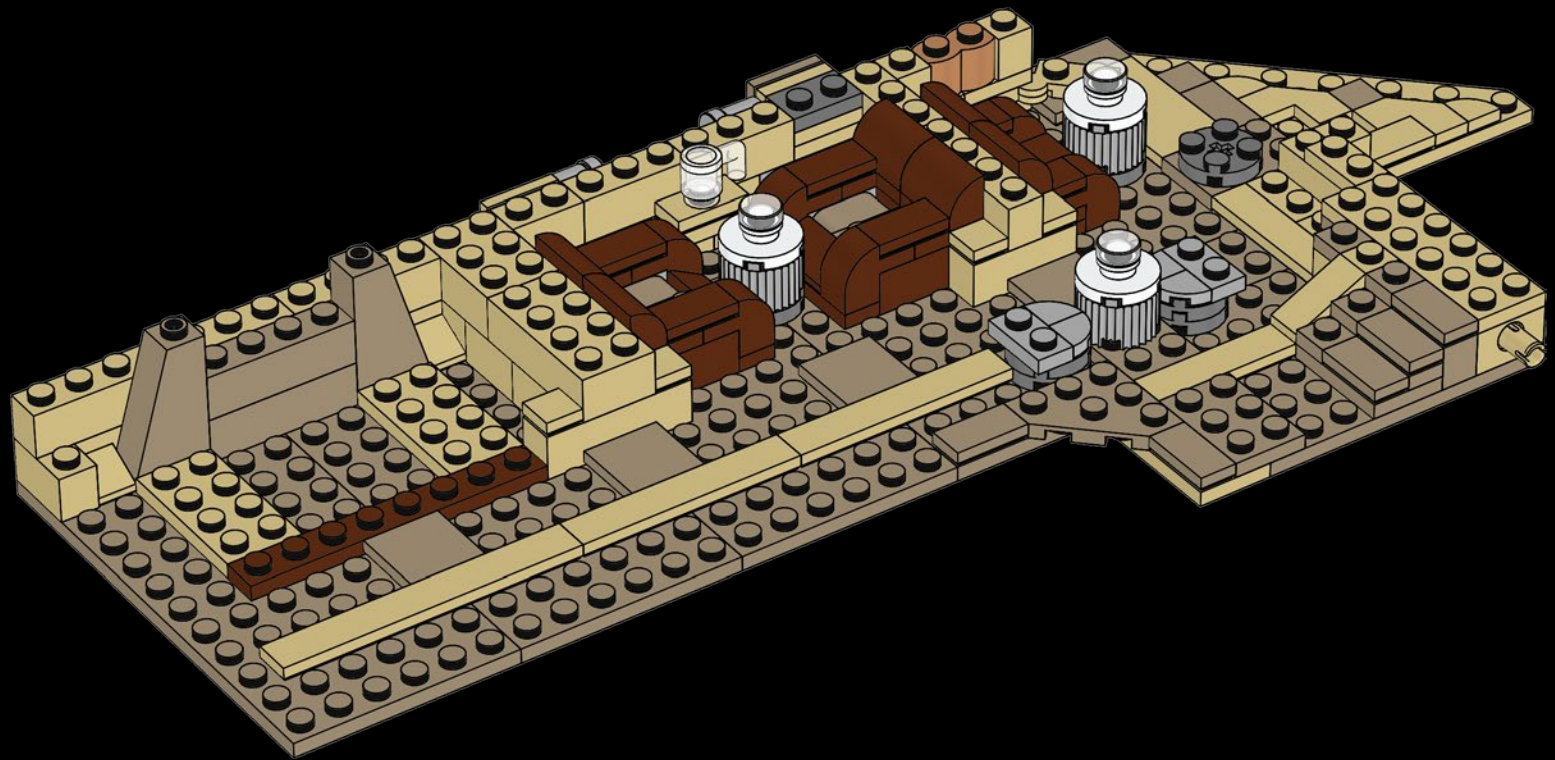

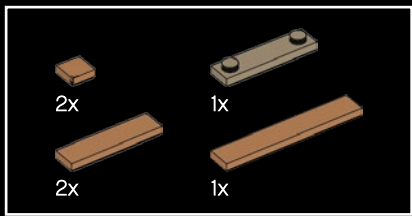

233

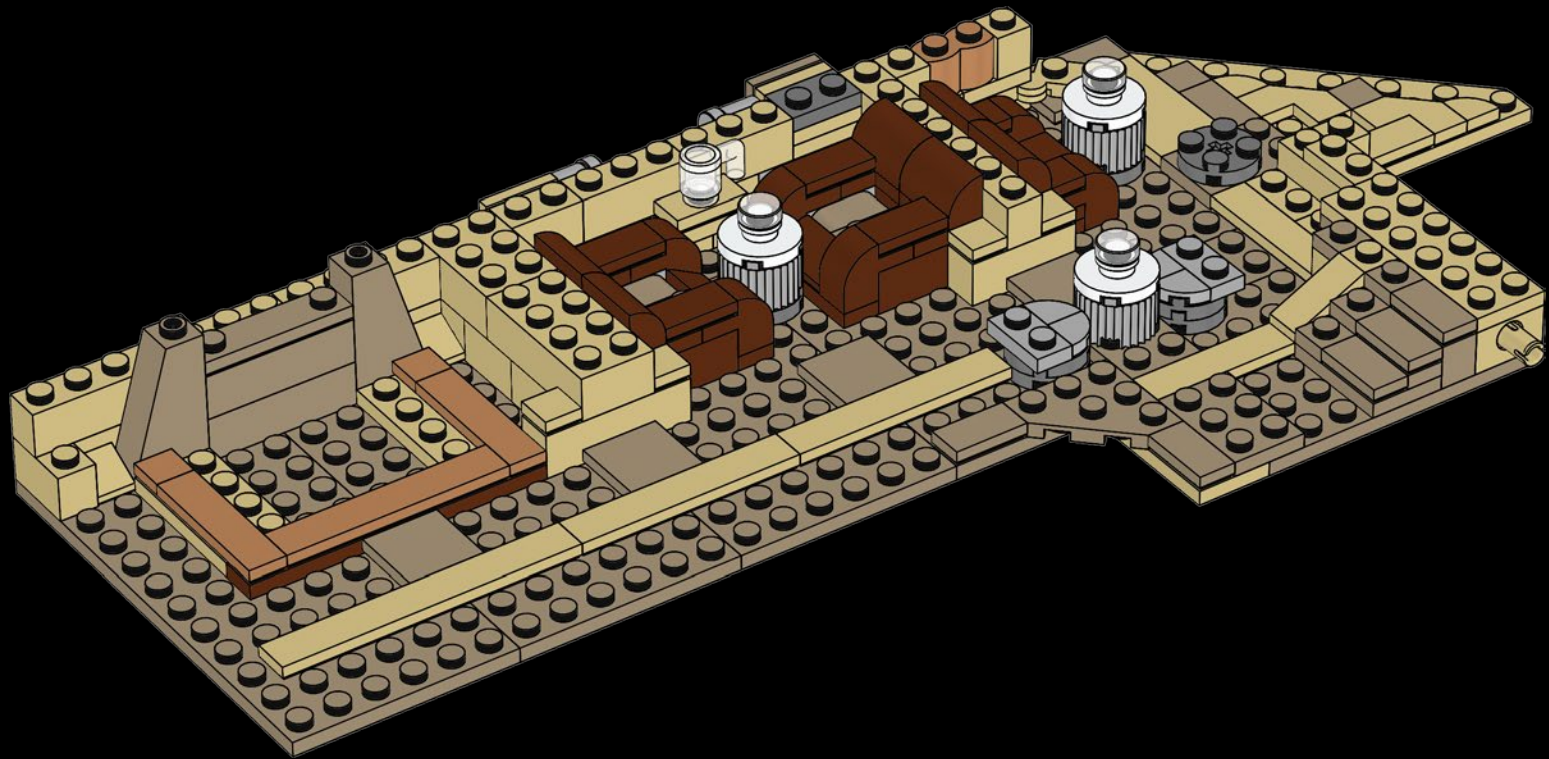

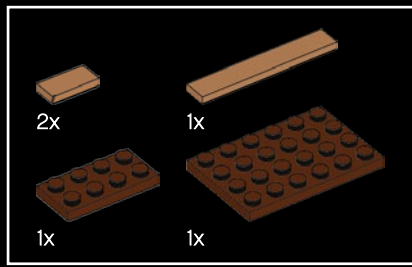

234

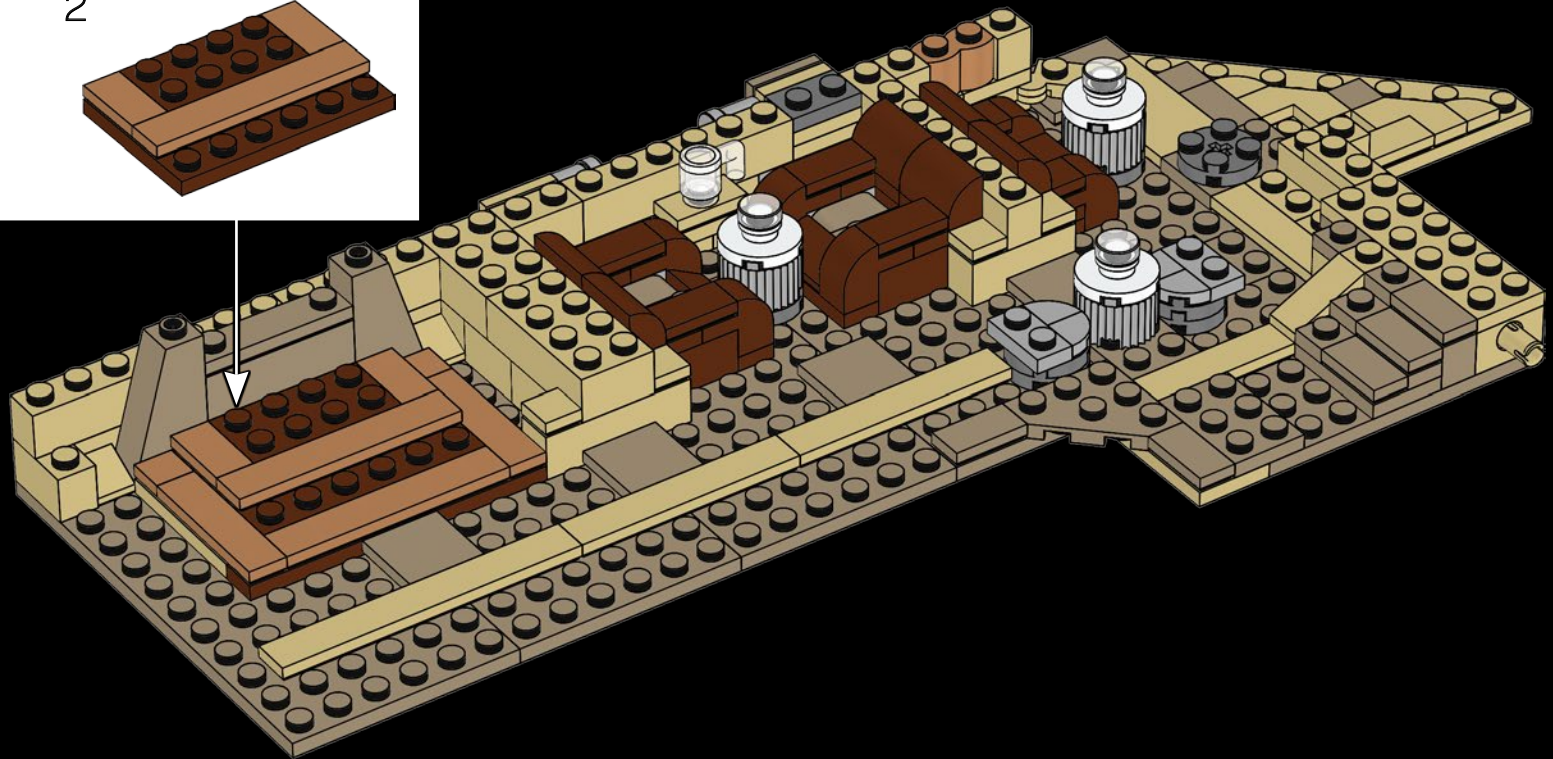
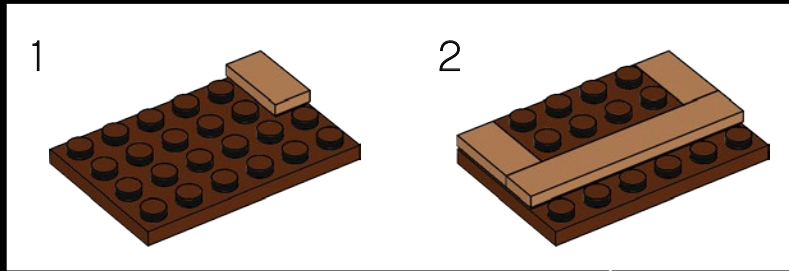

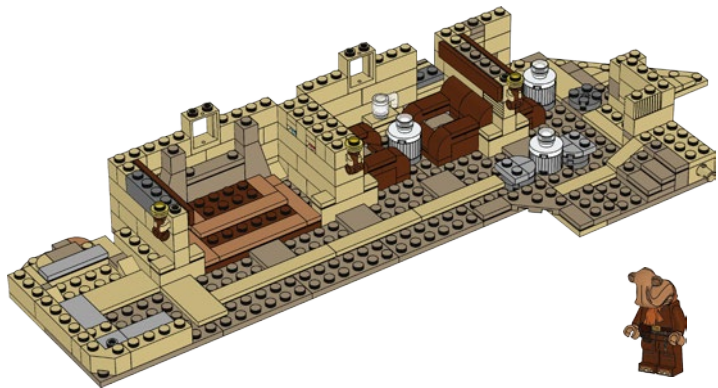
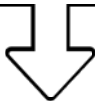

Momaw Nadon, also known as “Hammerhead,” is an Ithorian and a Rebel sympathizer. He was exiled from his home planet of Ithor after he was forced to reveal his species’ agricultural secrets to the Empire. He maintains a secret garden in the mountains south of the Mos Eisley Spaceport.

Momaw Nadon, aussi connu sous le nom de « Tête de marteau », est un Ithorien et un sympathisant rebelle. Il a été exilé d’Ithor, sa planète natale, après avoir été forcé à révéler les secrets agricoles de son espèce à l’Empire. Il entretient un jardin secret dans les montagnes au sud de l’astroport de Mos Eisley.

Momaw Nadon, también conocido como Hammerhead, es un Ithoriano que simpatiza con la causa rebelde. Se exilió de su planeta natal, Ithor, luego de ser obligado a revelar los secretos agrícolas de su especie al Imperio. Cuida de un huerto secreto en las montañas, al sur del puerto espacial de Mos Eisley.

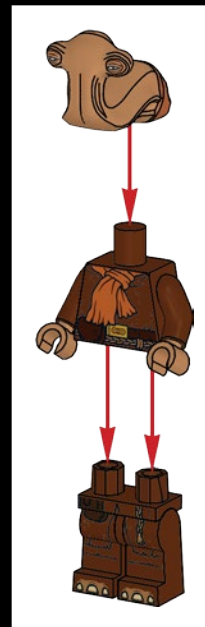

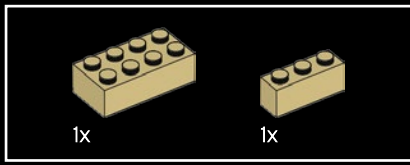

235

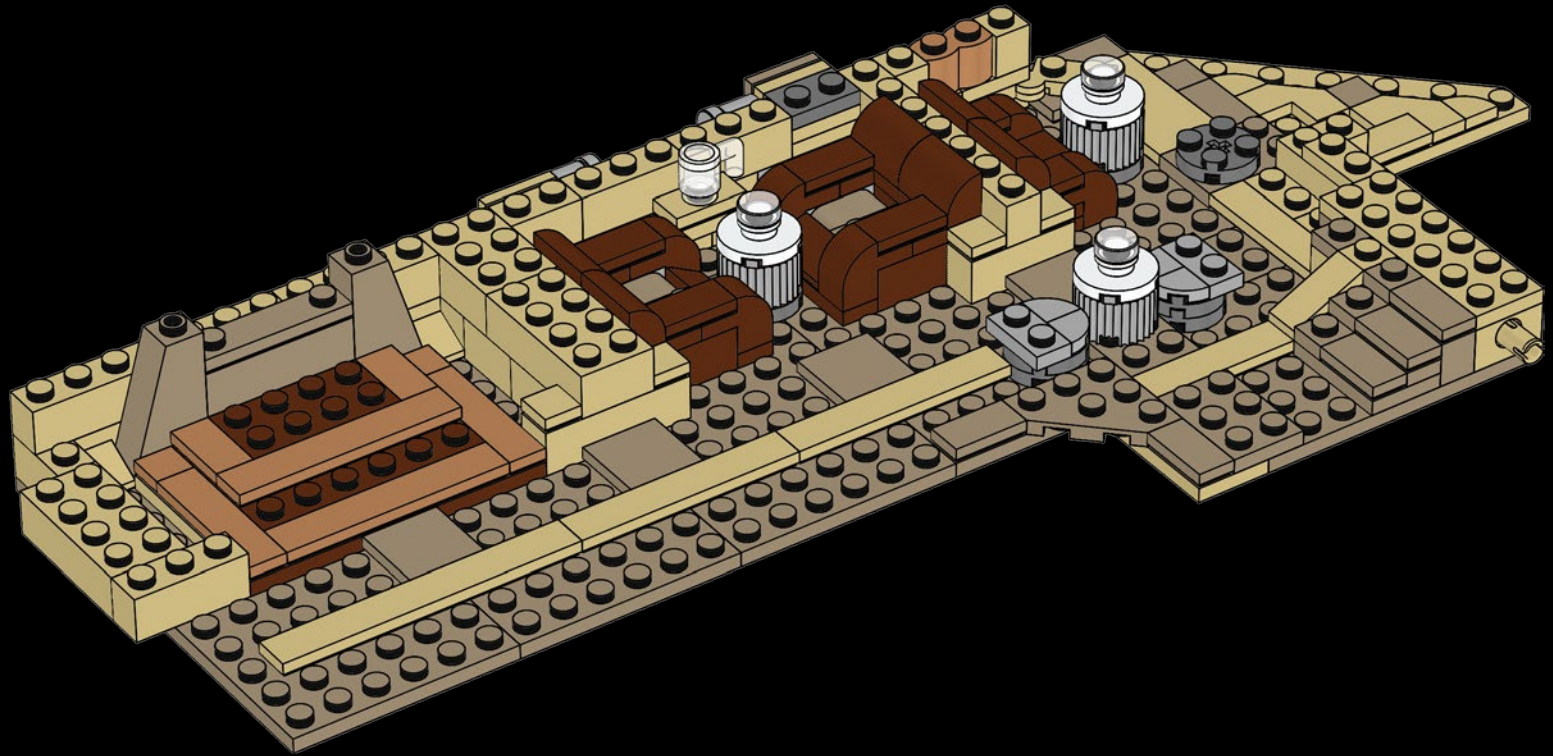

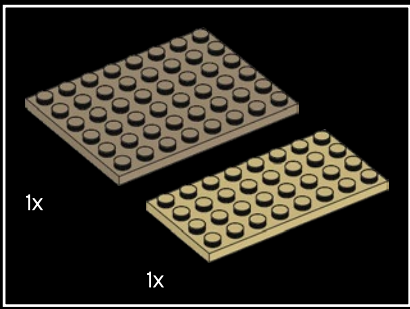

236

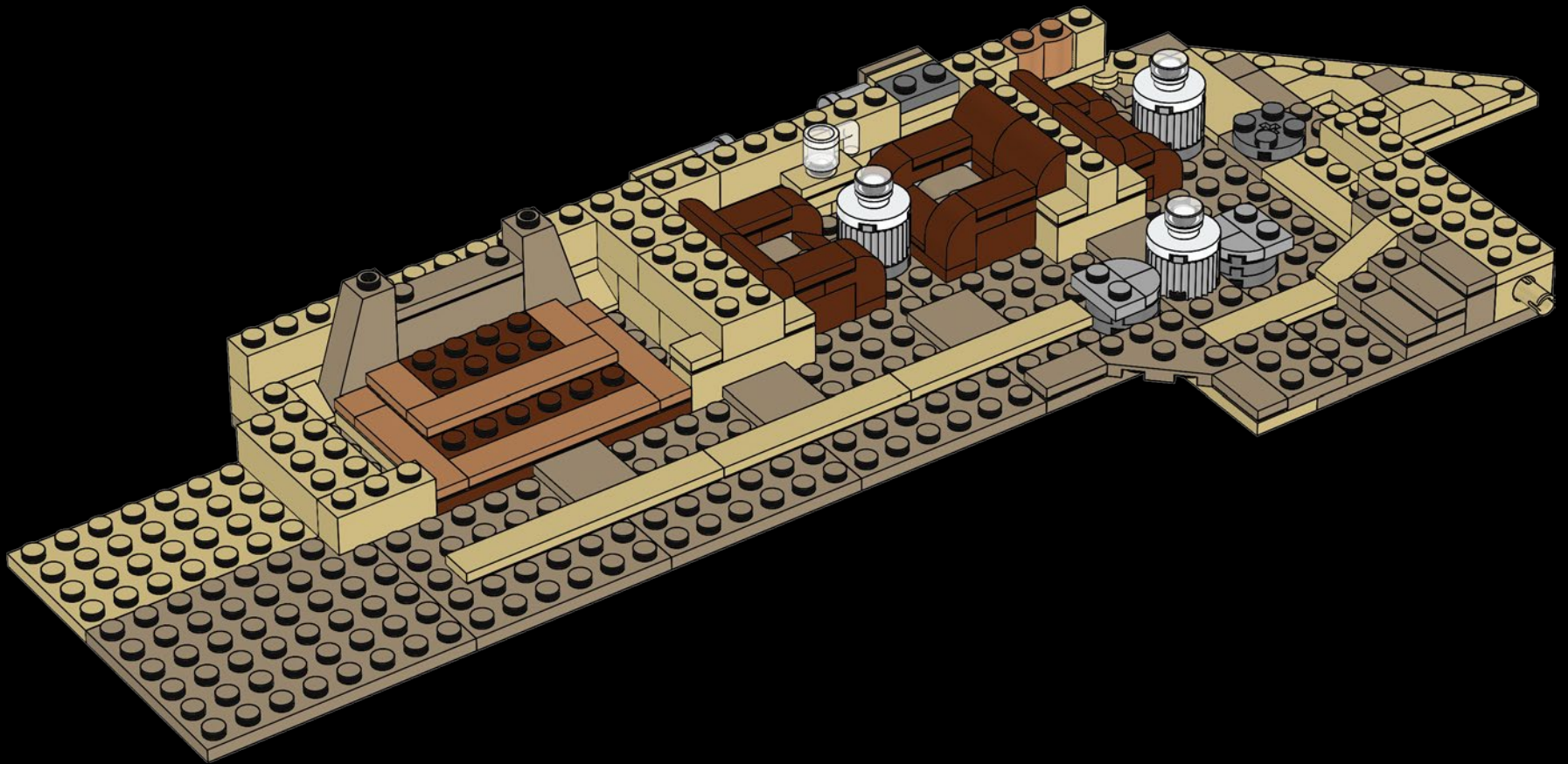

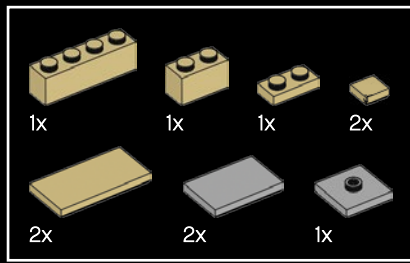

237

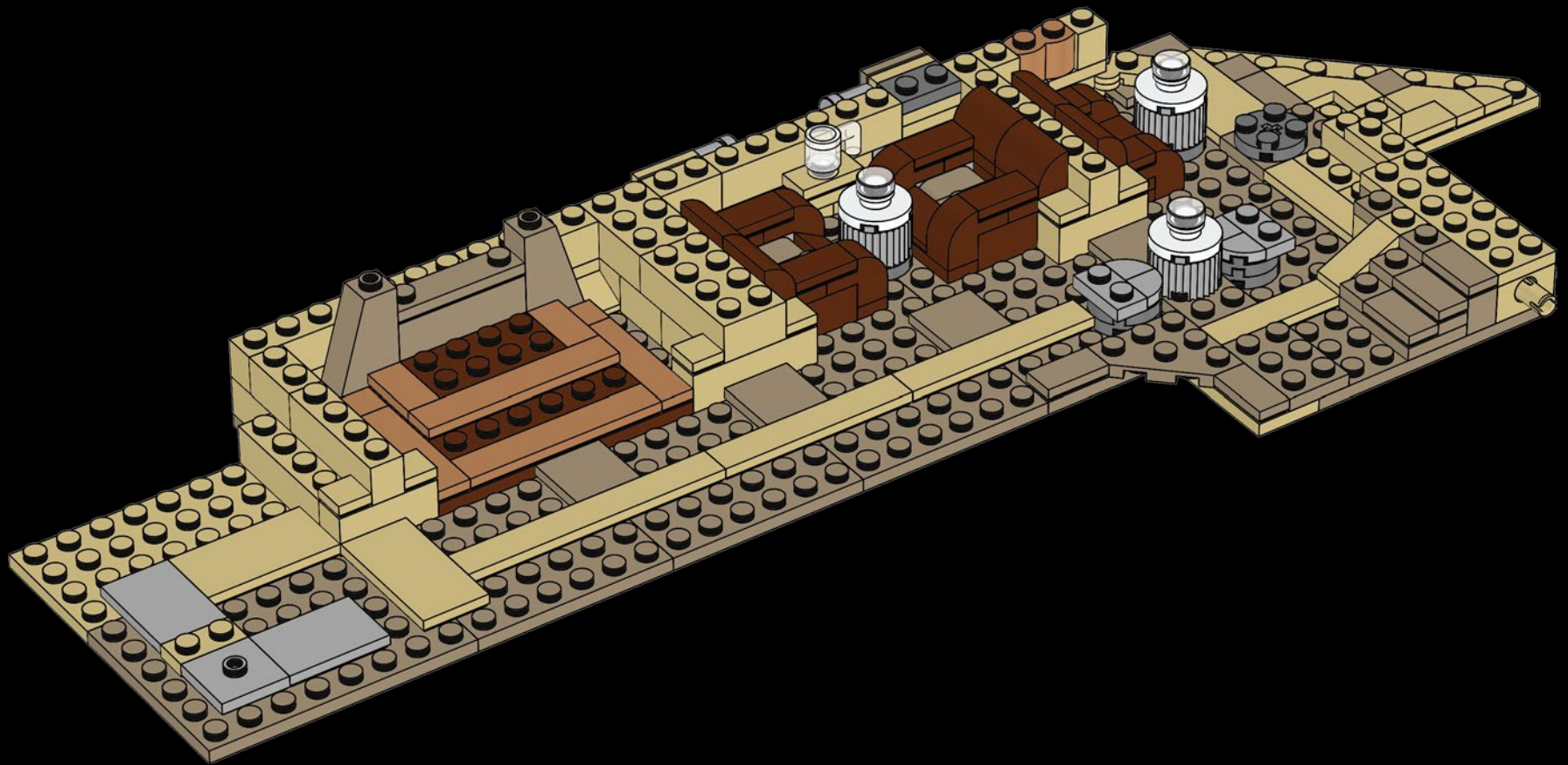

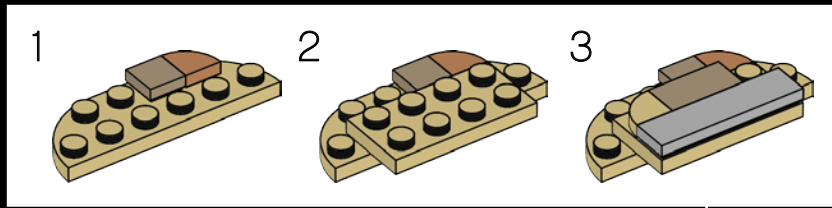
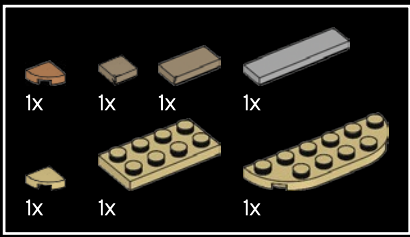

238

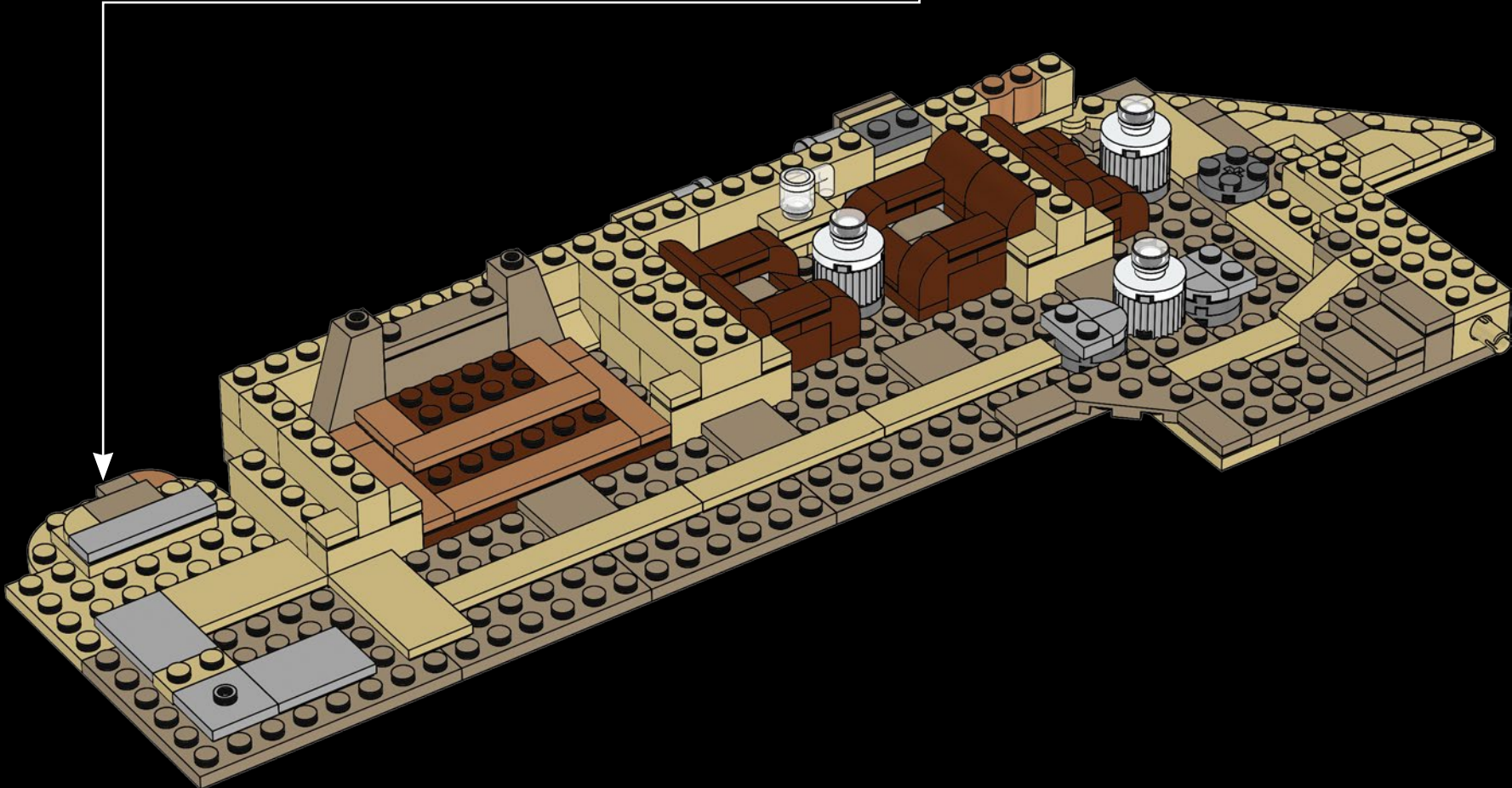



239

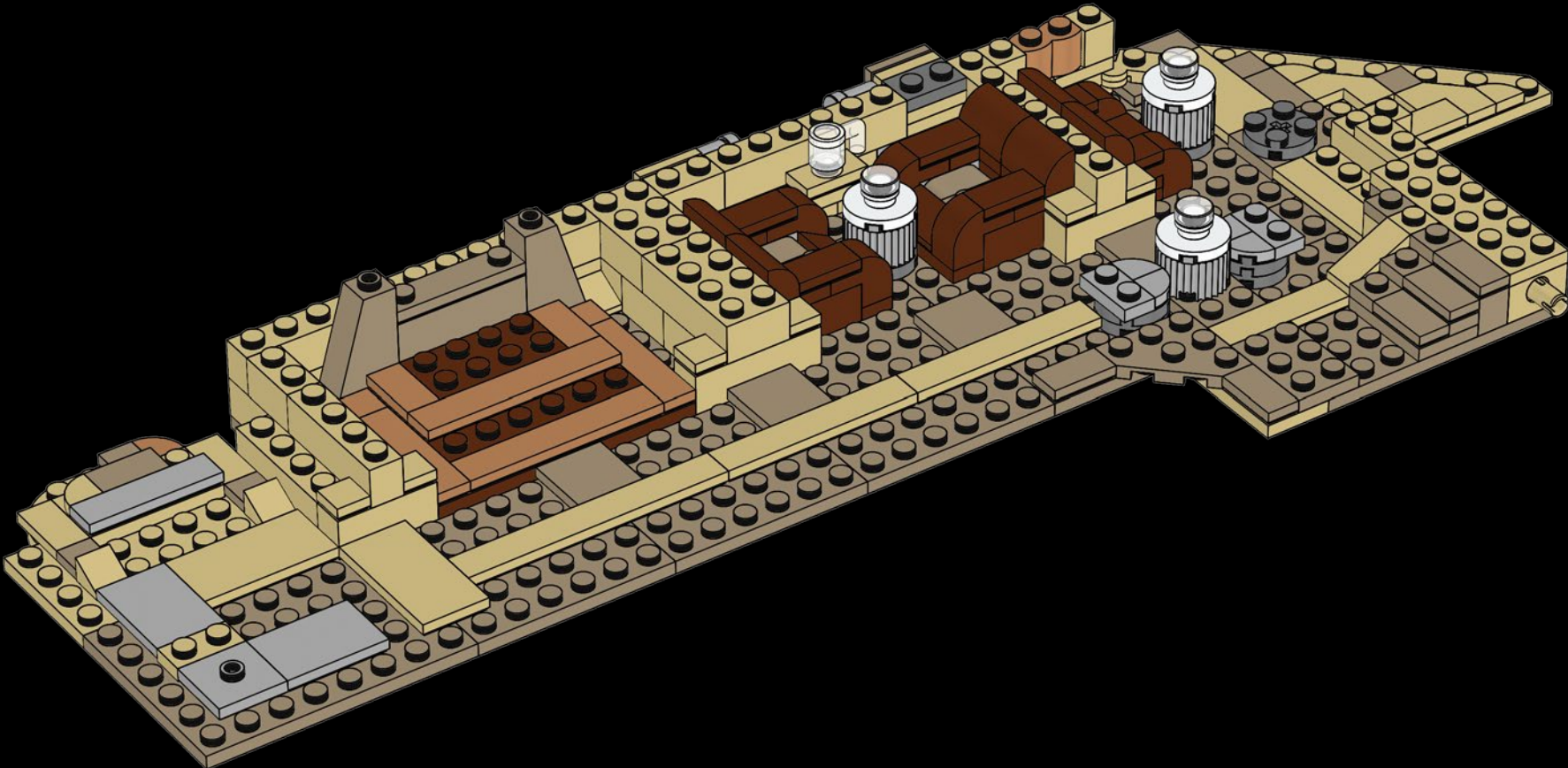

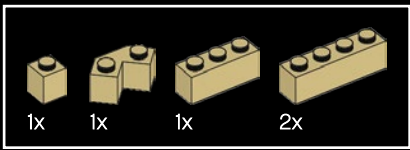

240

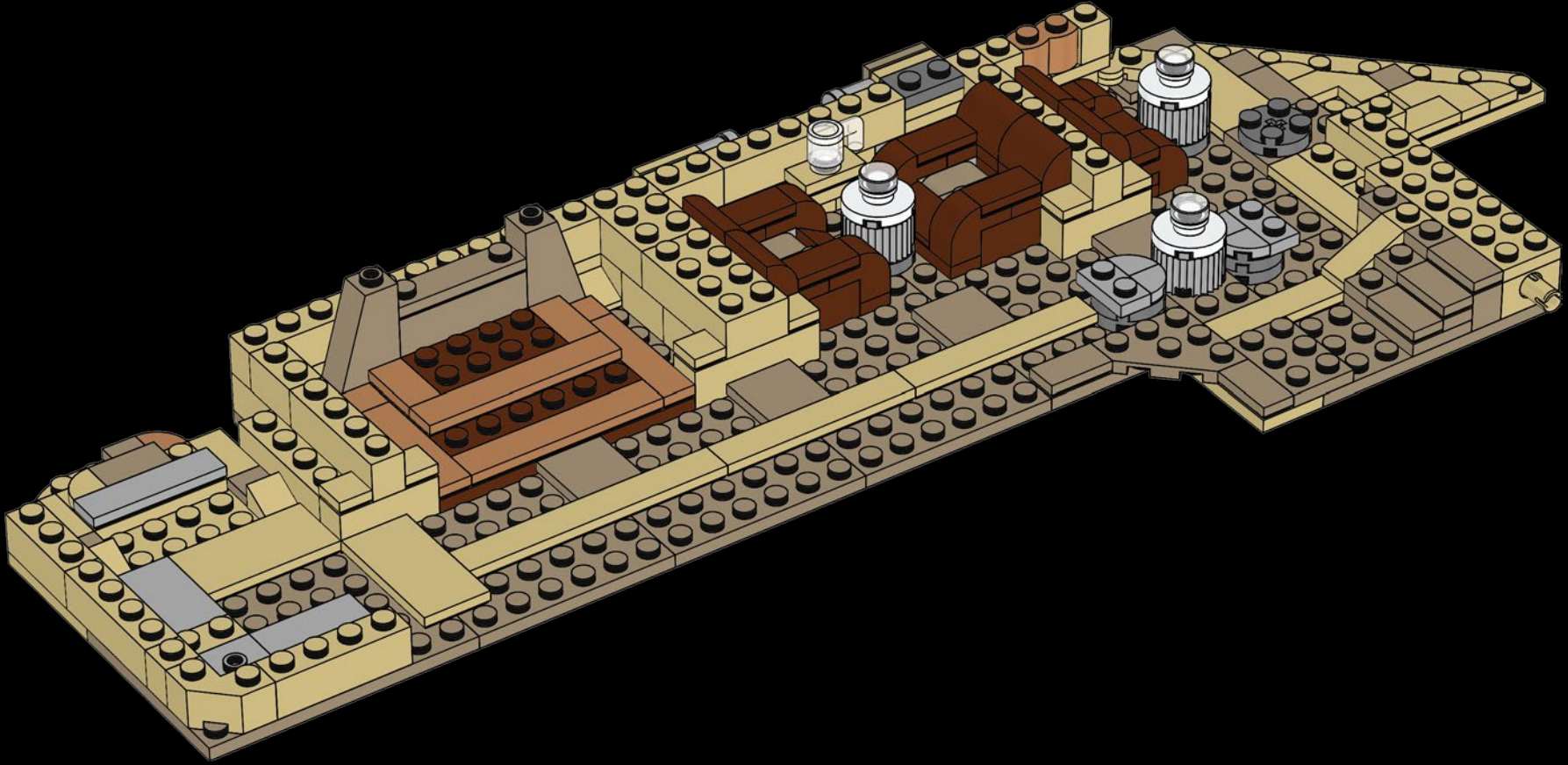

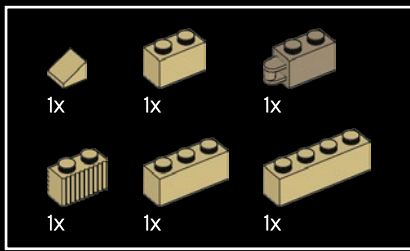

241

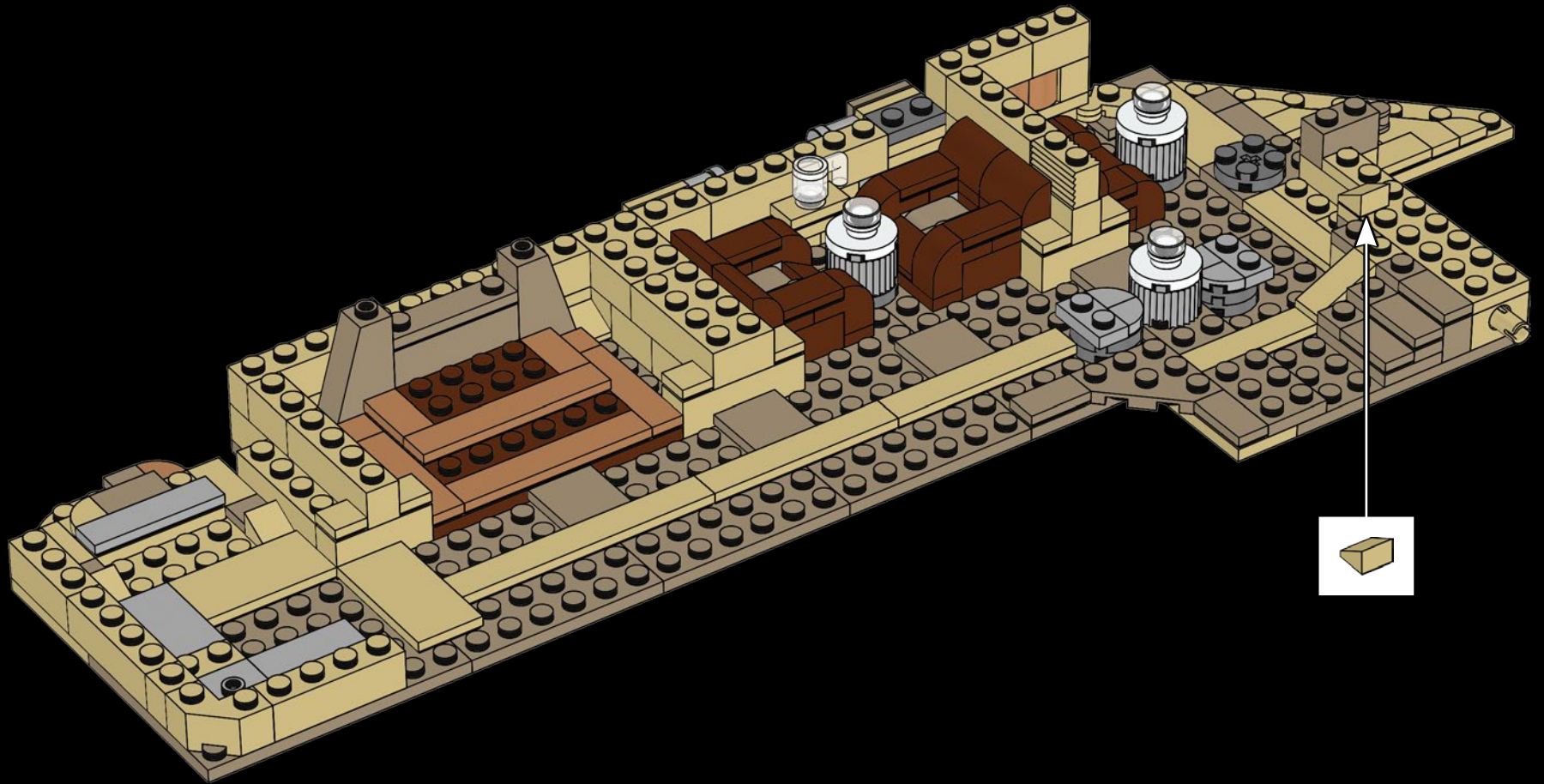

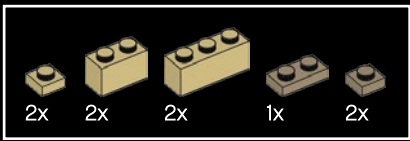

242

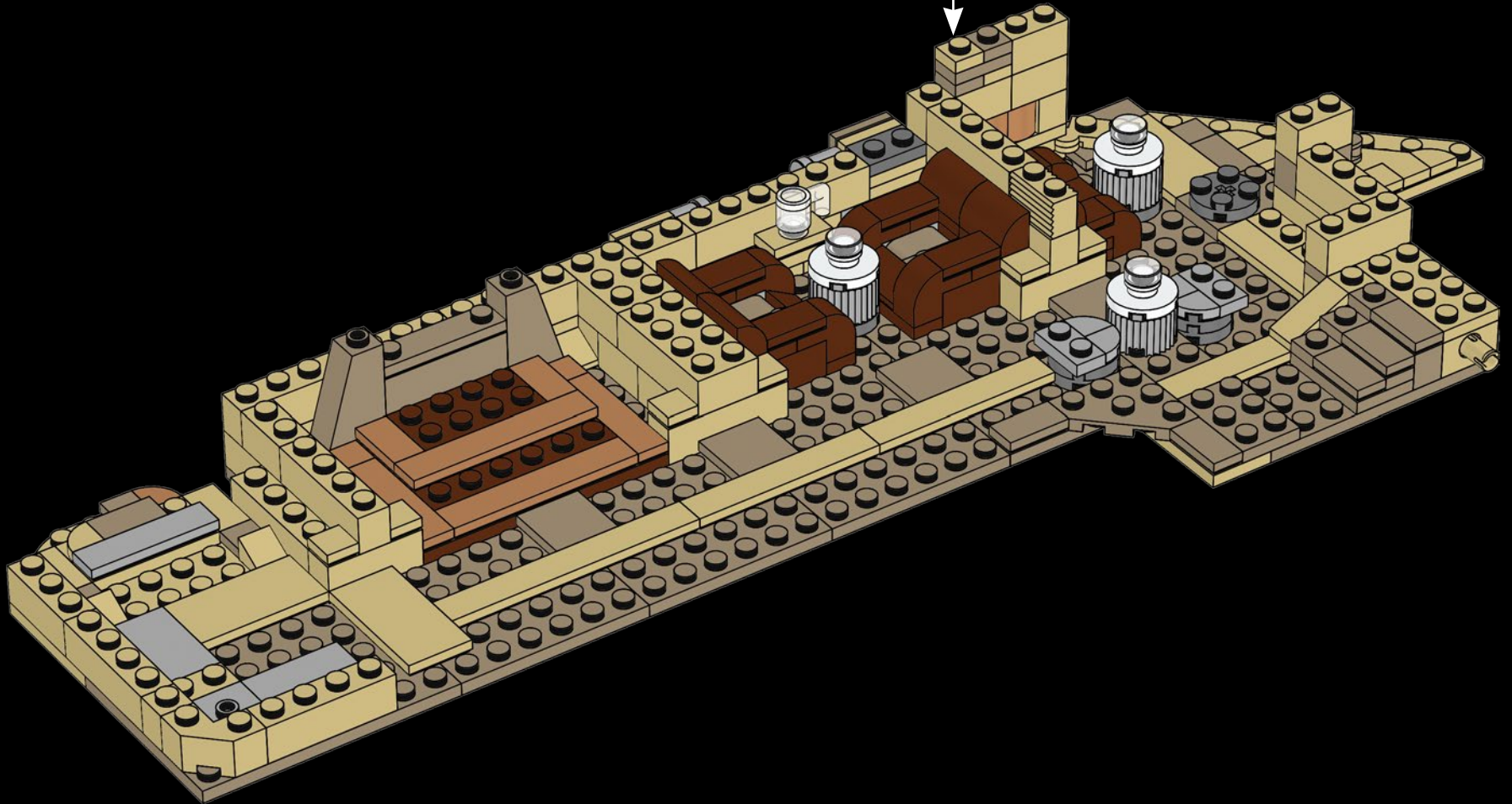
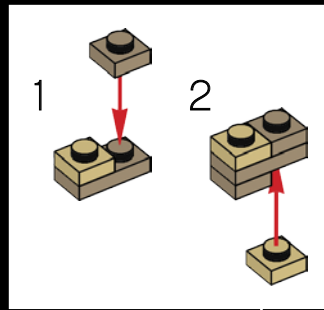

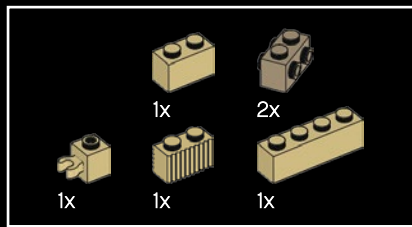

243

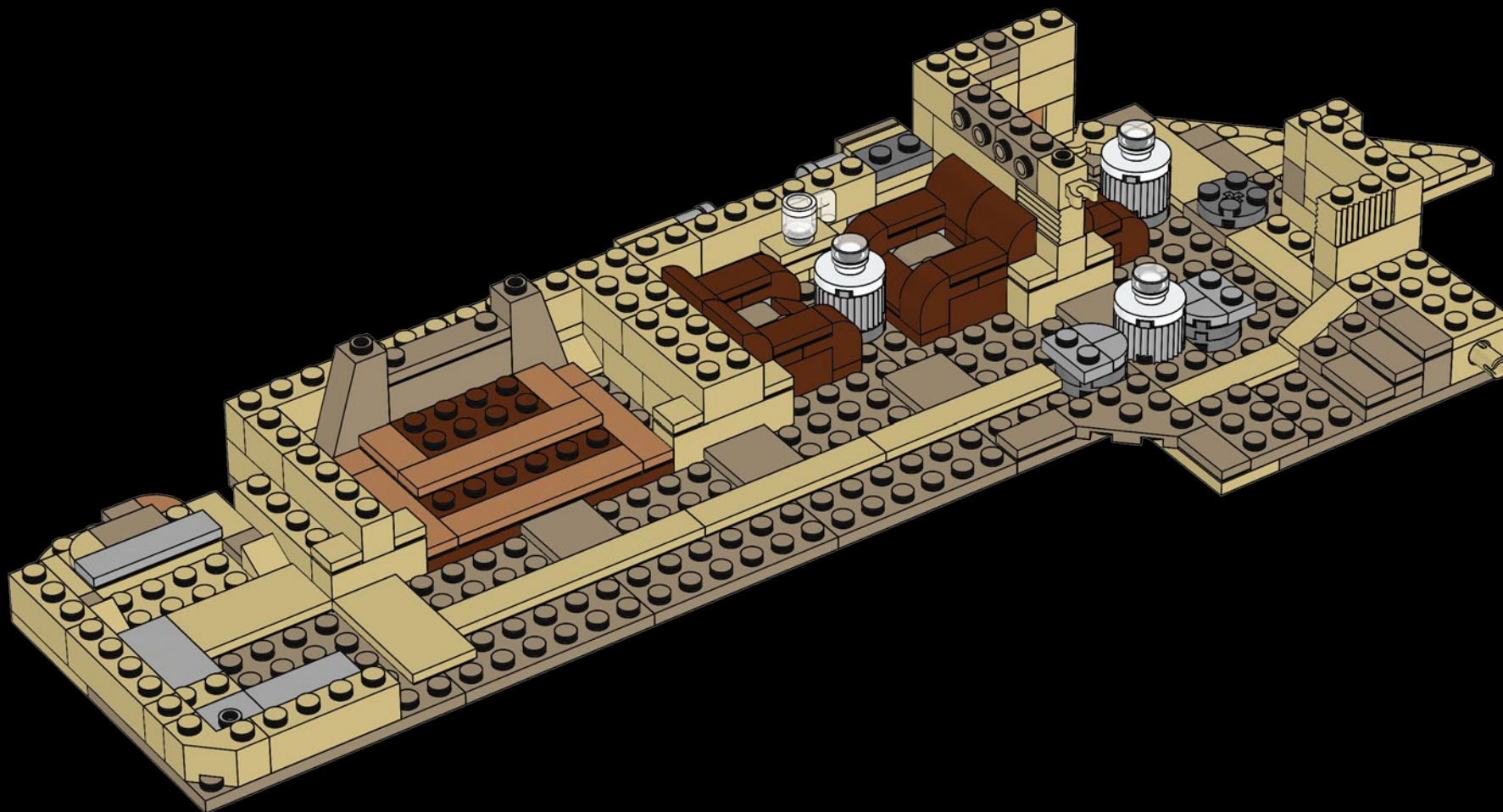

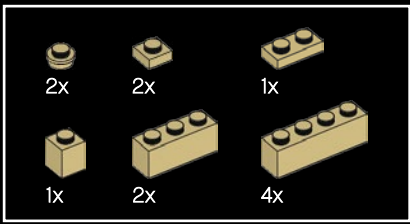

244

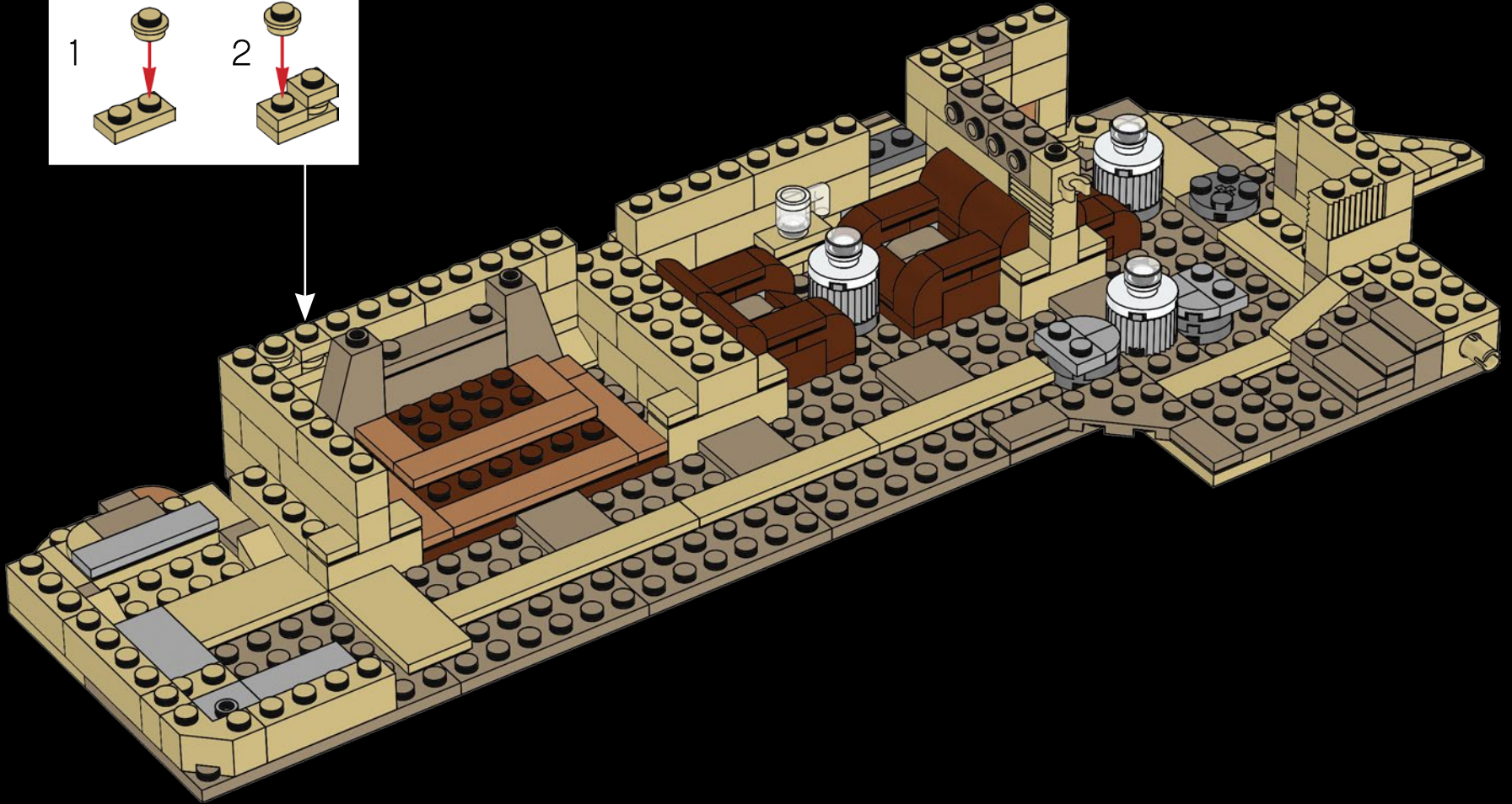
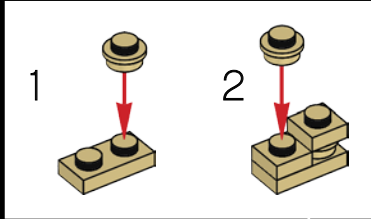

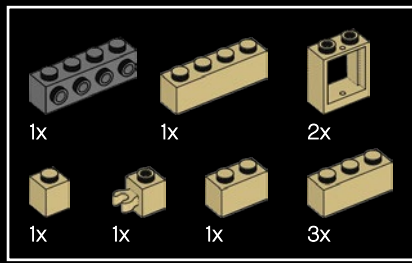

245

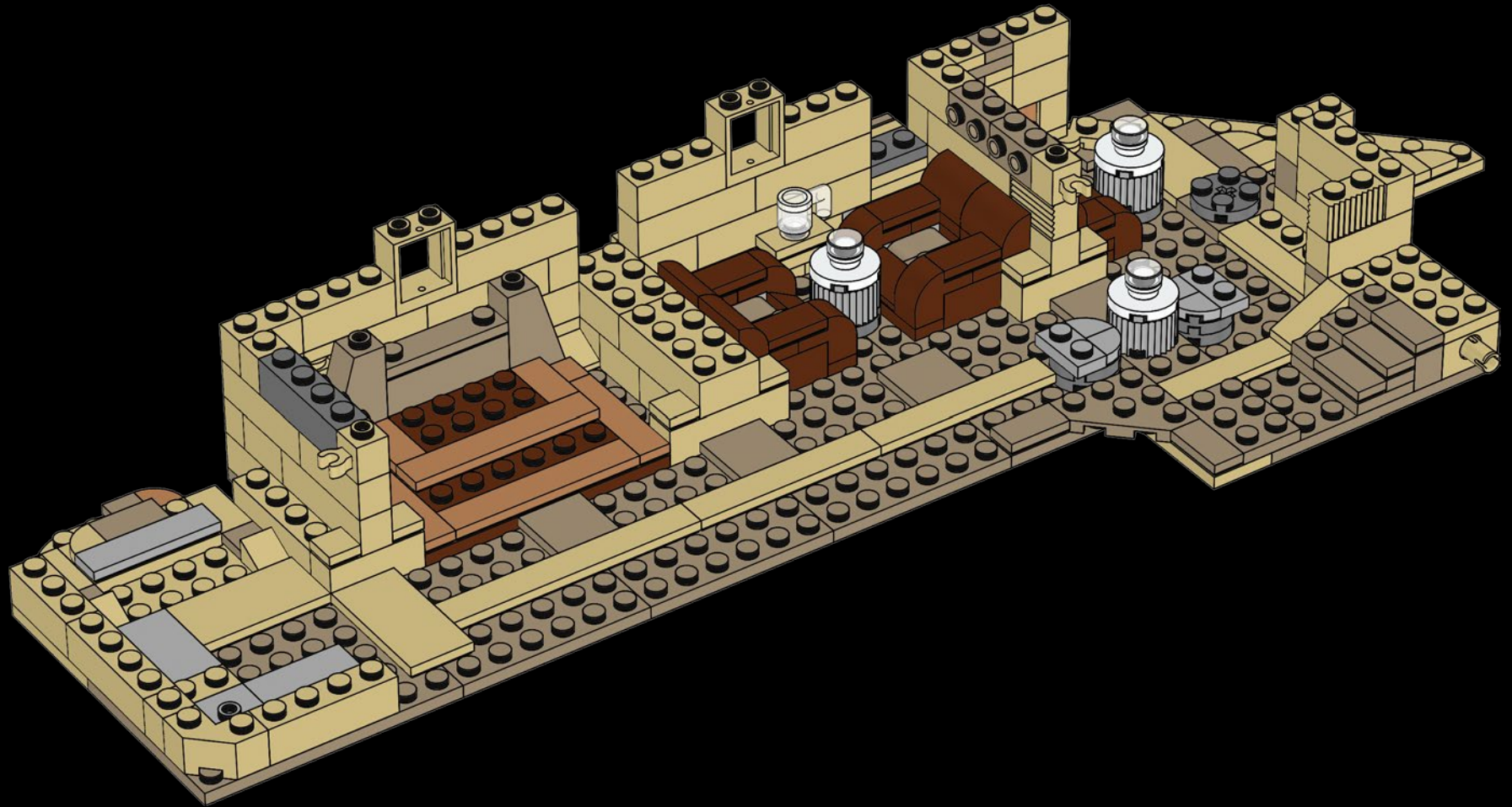

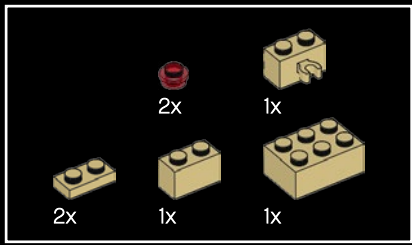

246

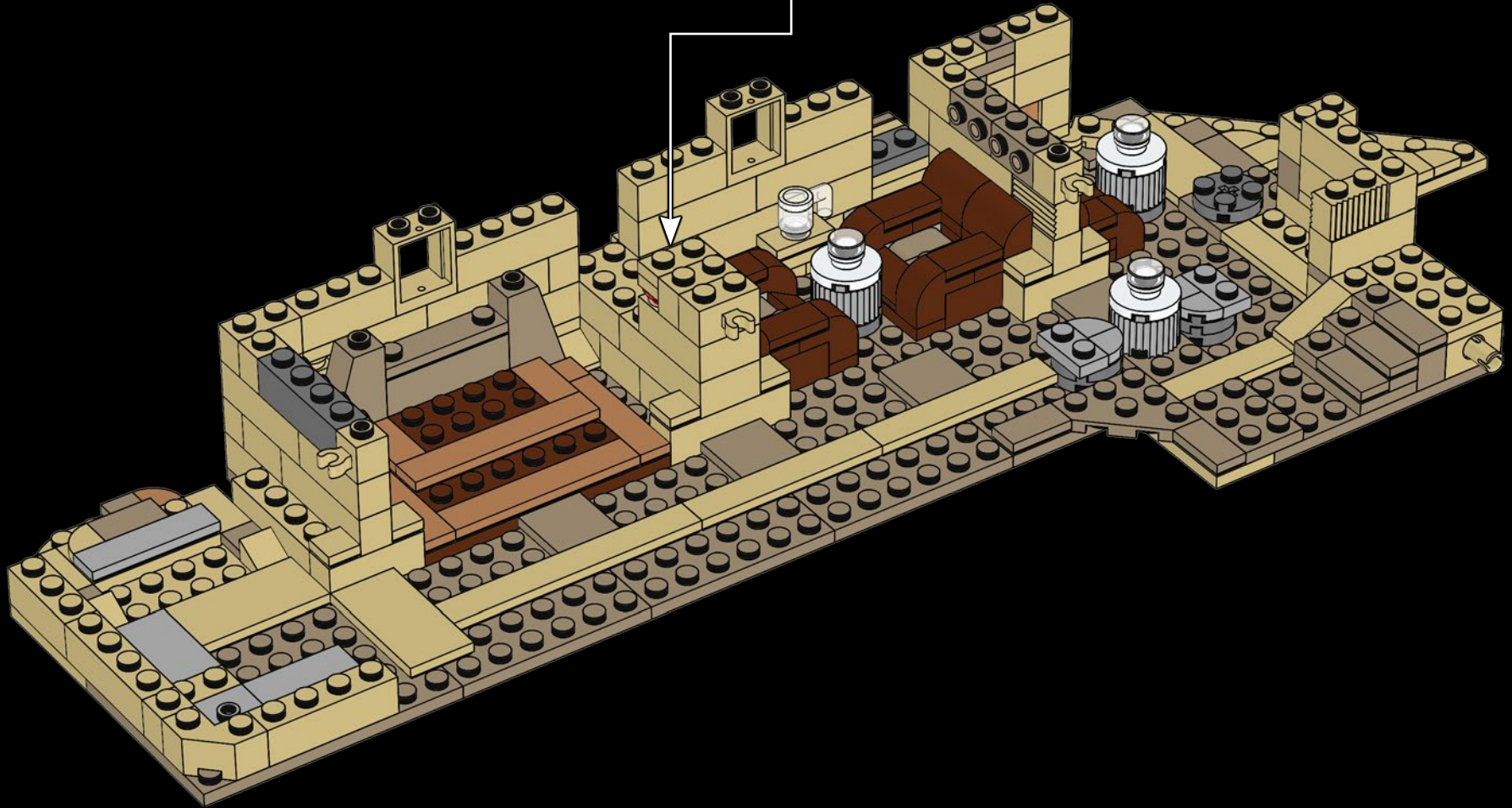
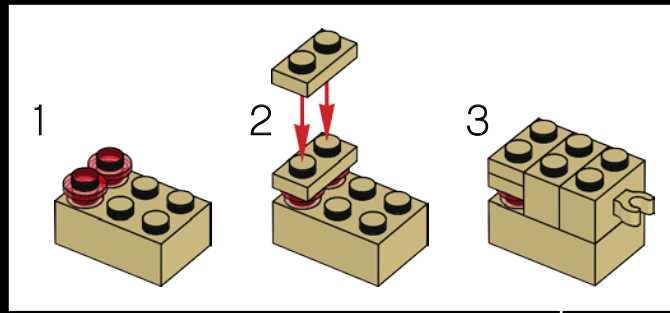

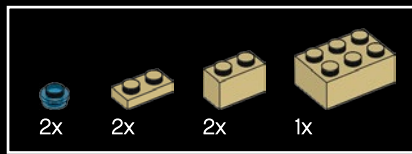

247

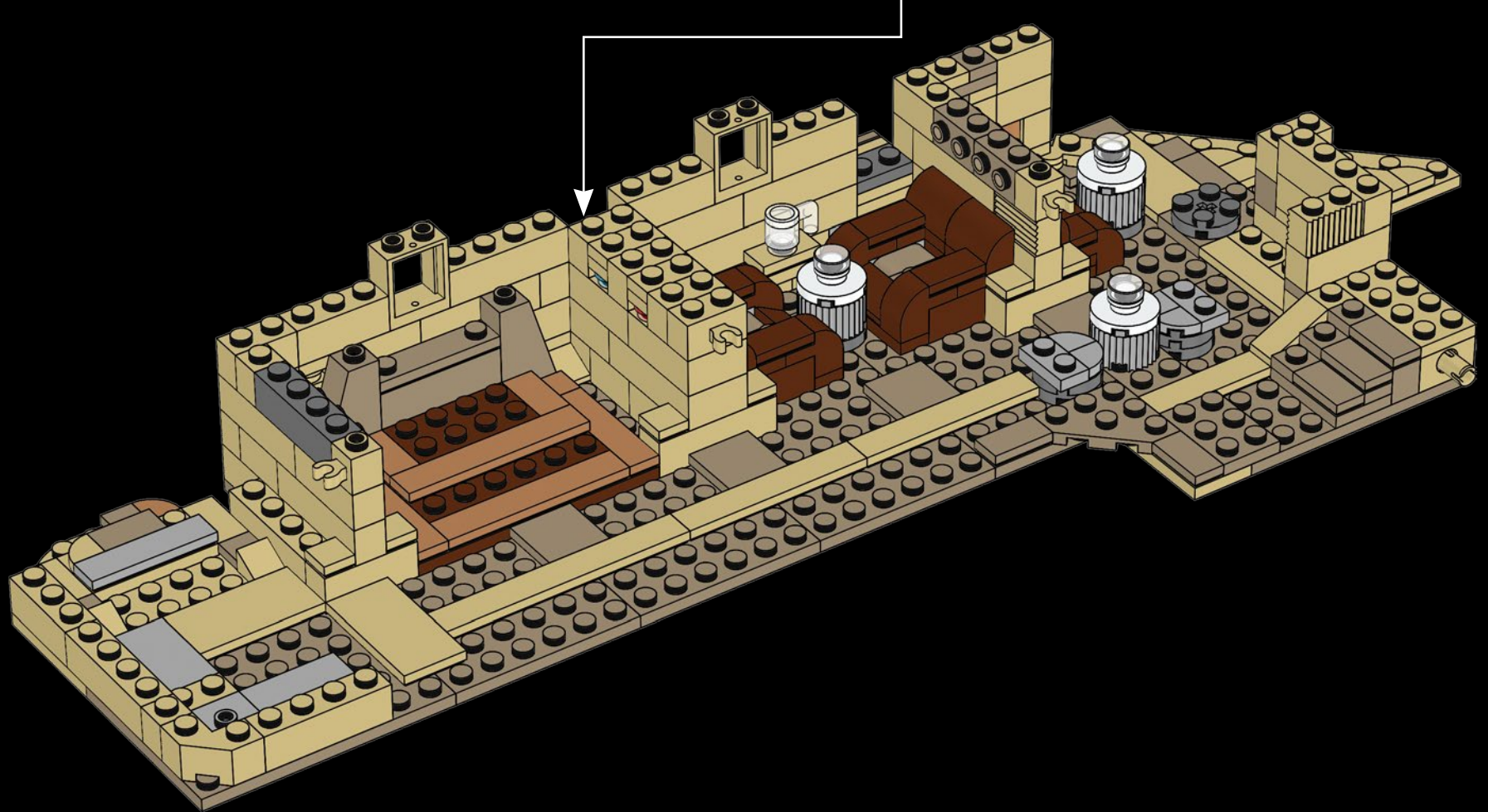
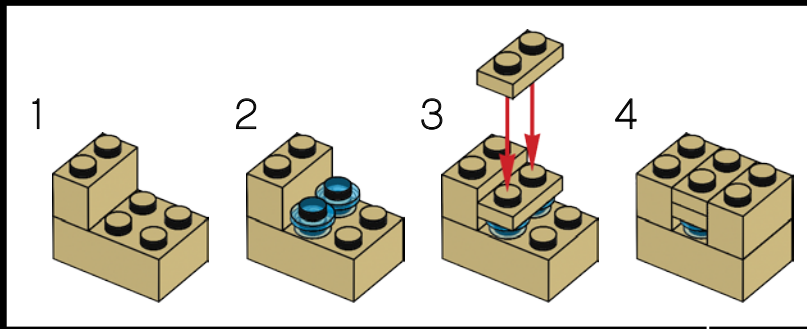



248

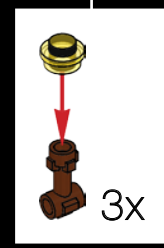
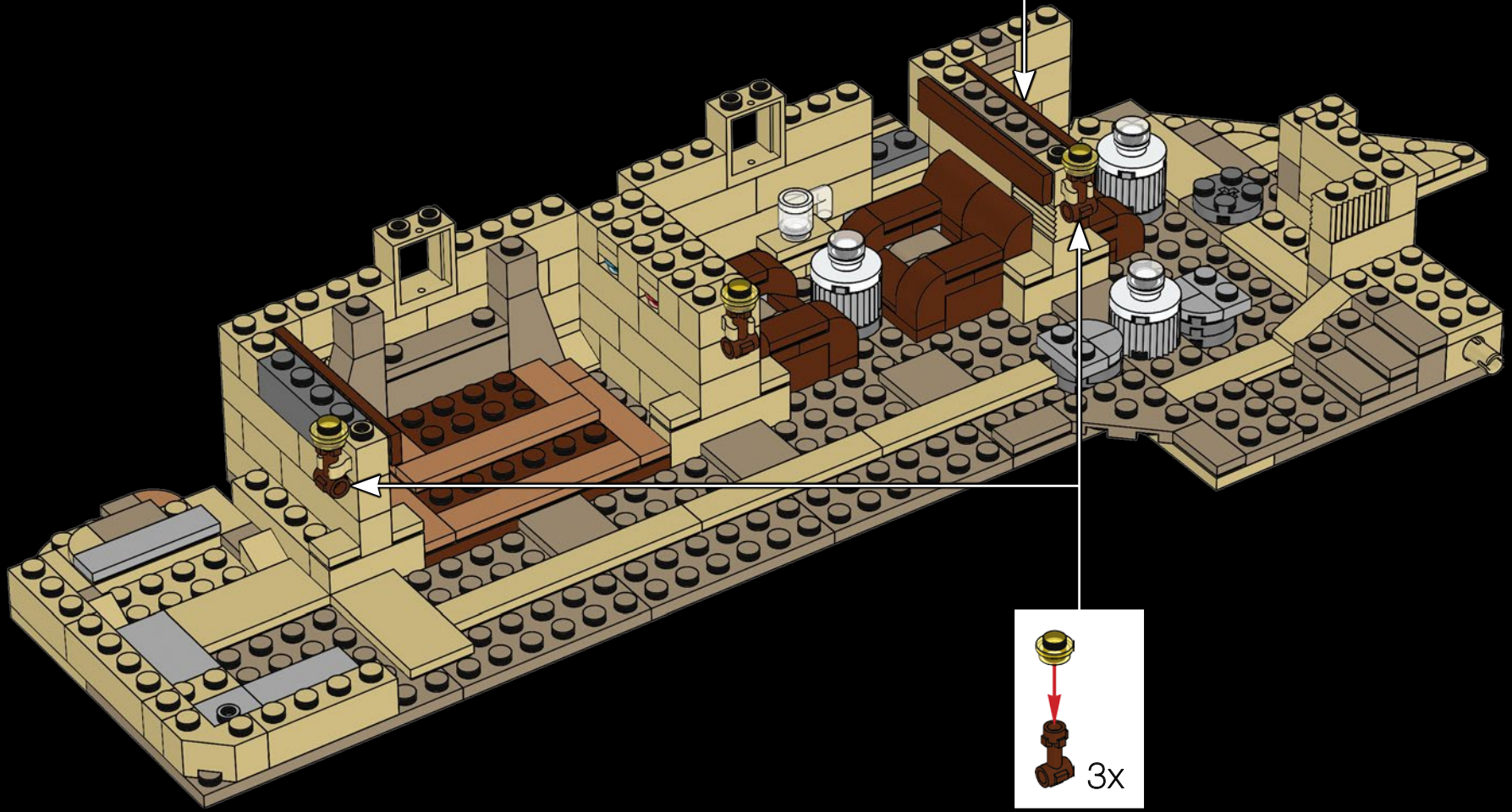
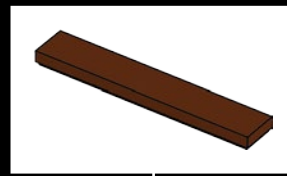

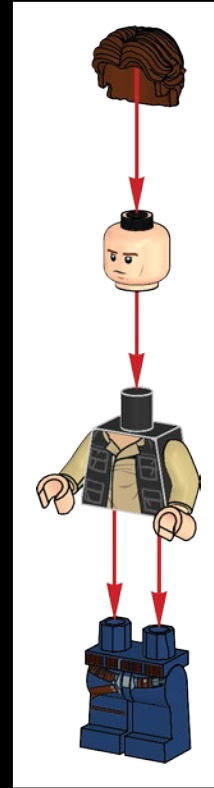
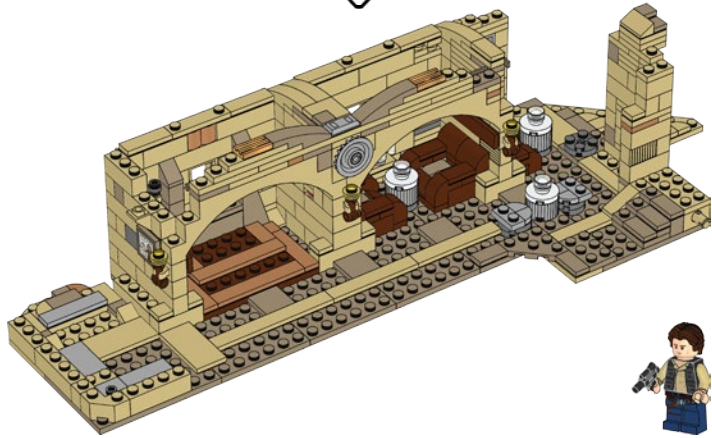
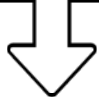

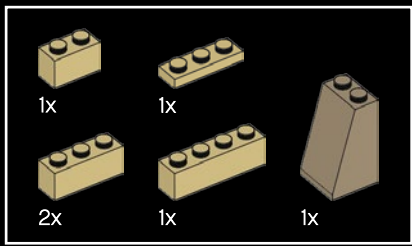

249

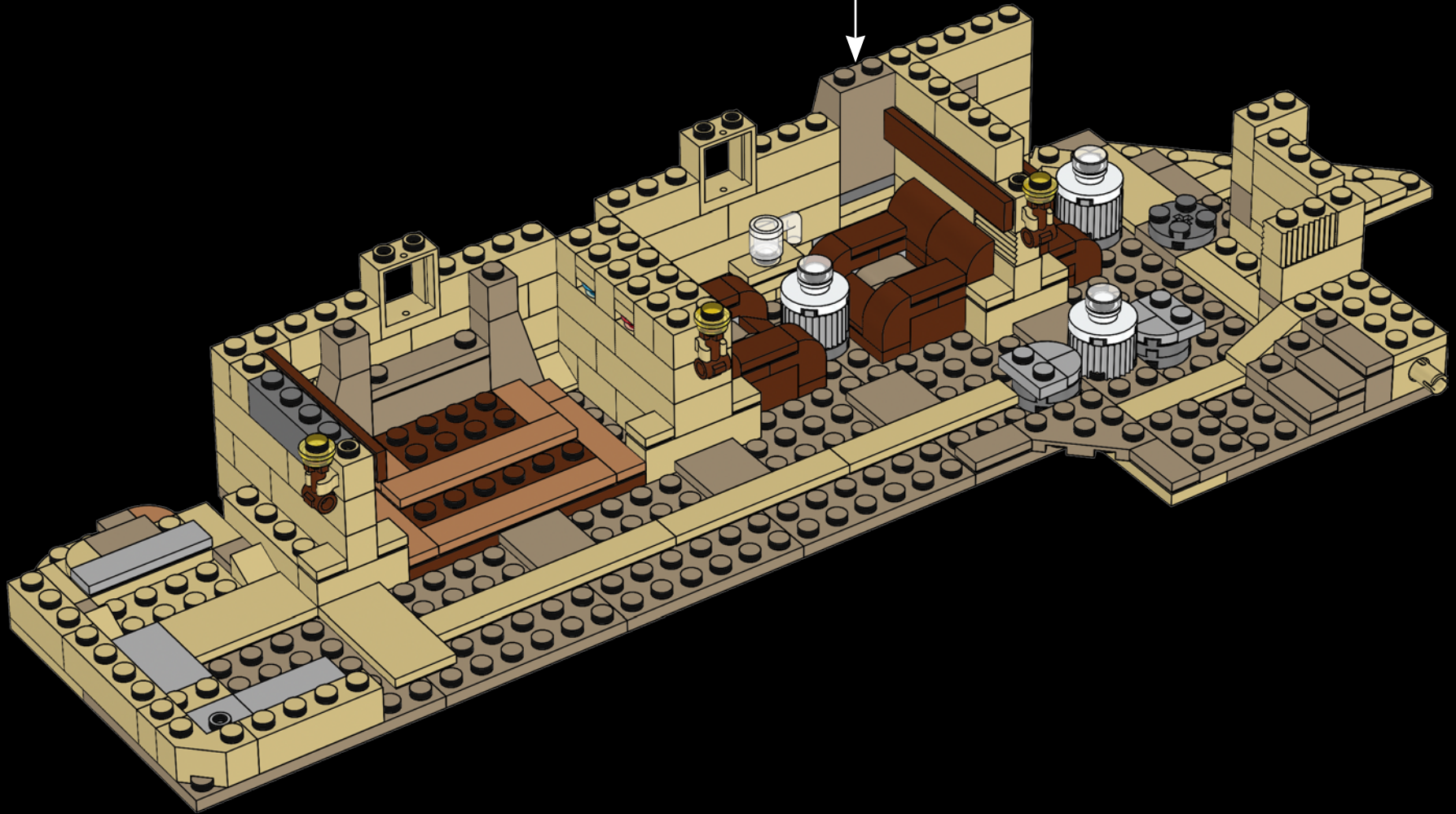
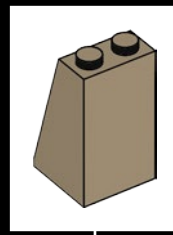

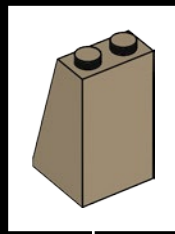
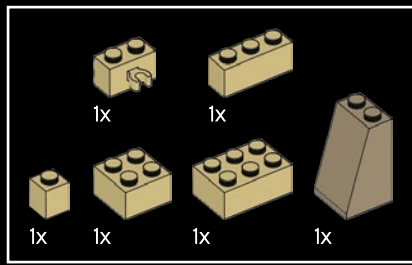

250

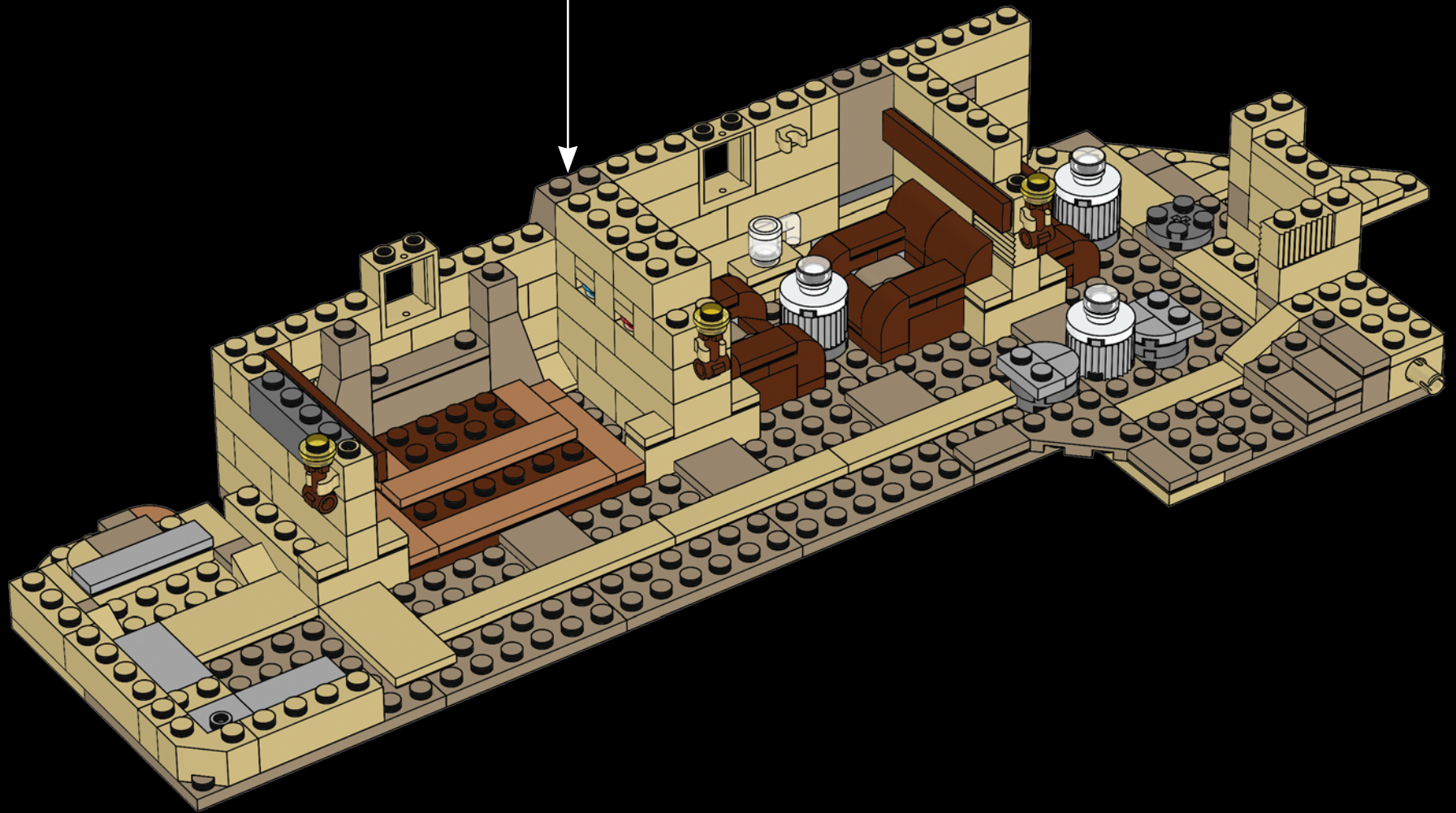

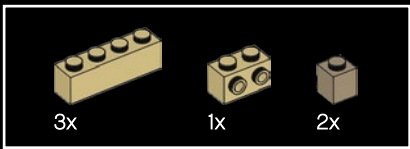

251

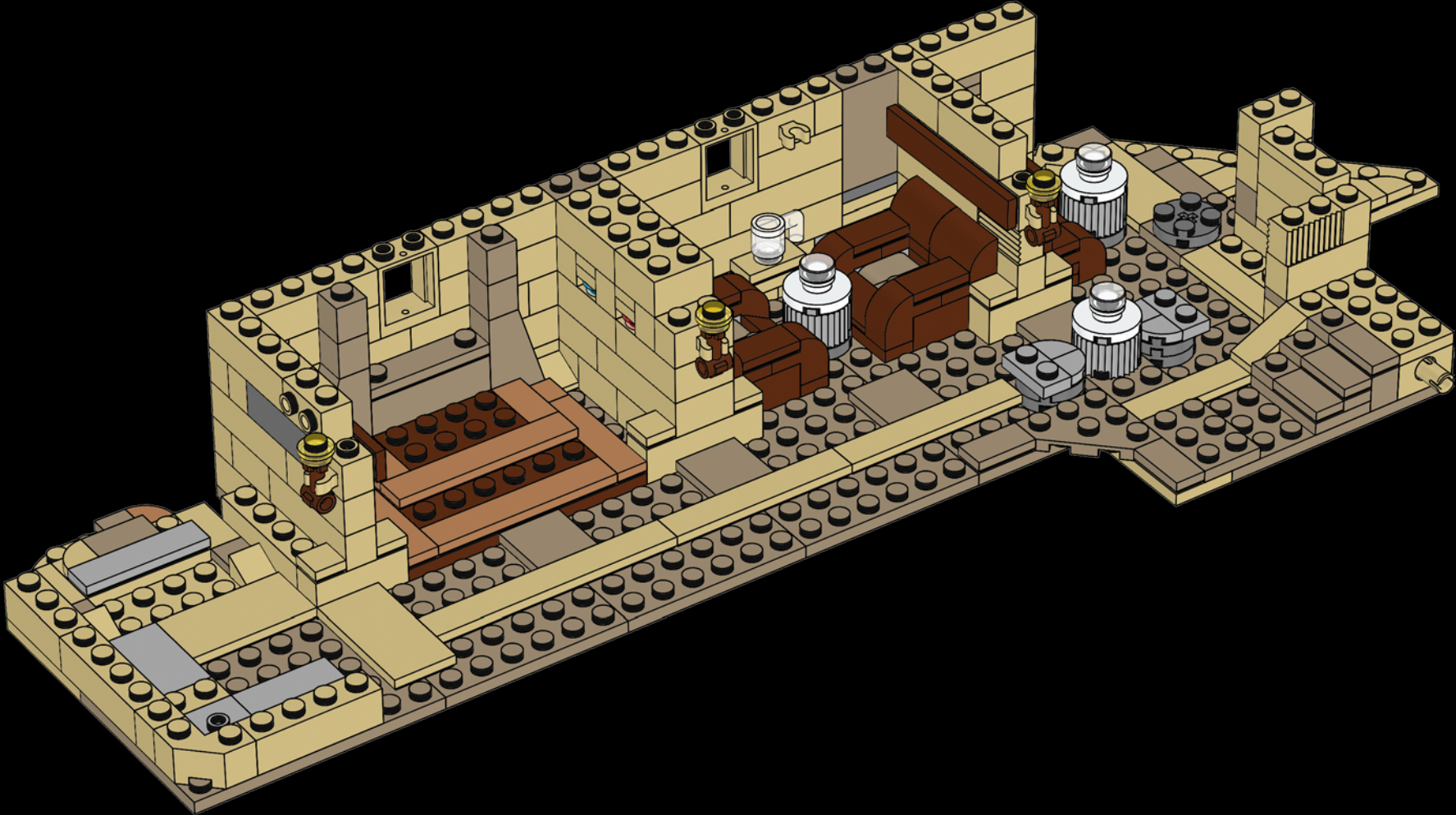

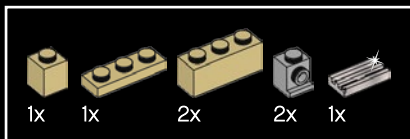

252

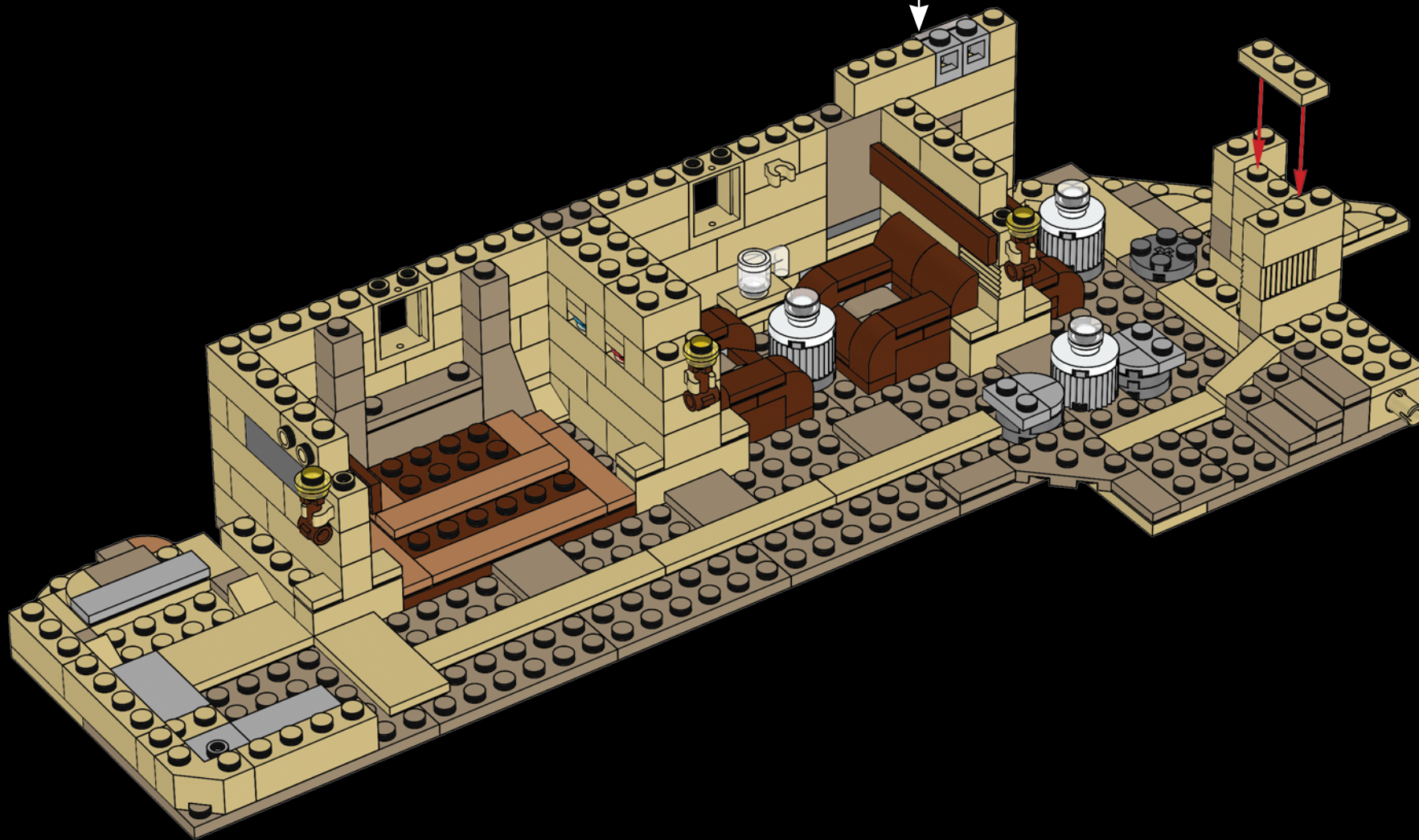
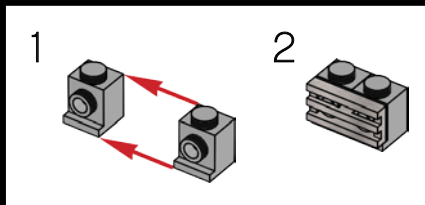

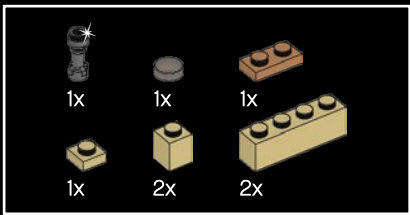

253

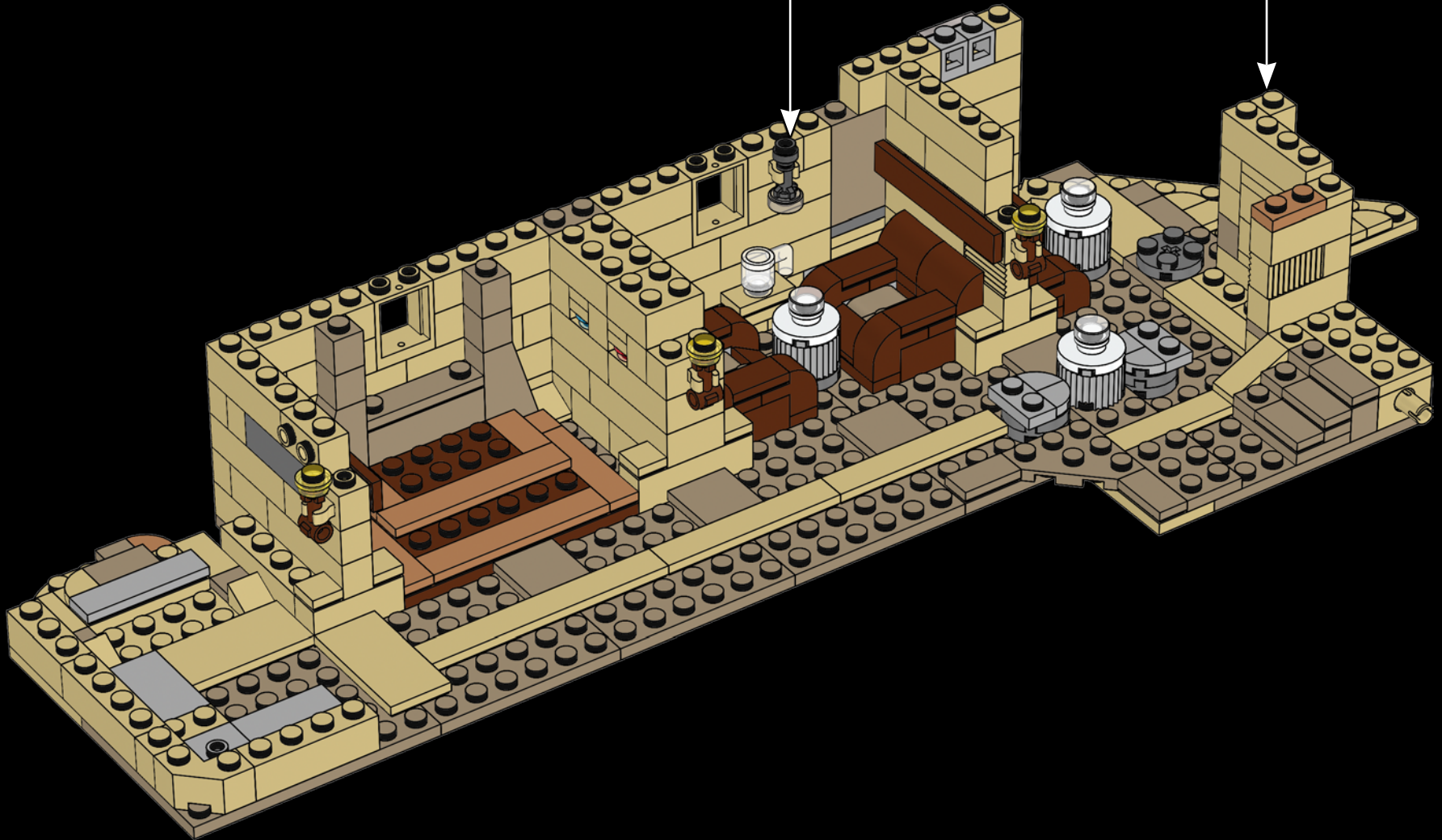
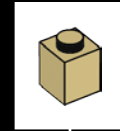
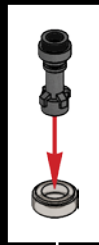

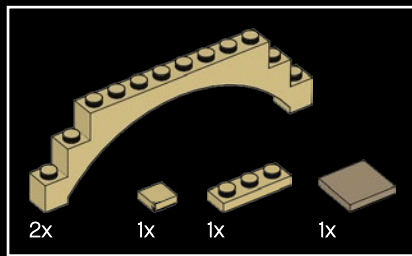

254

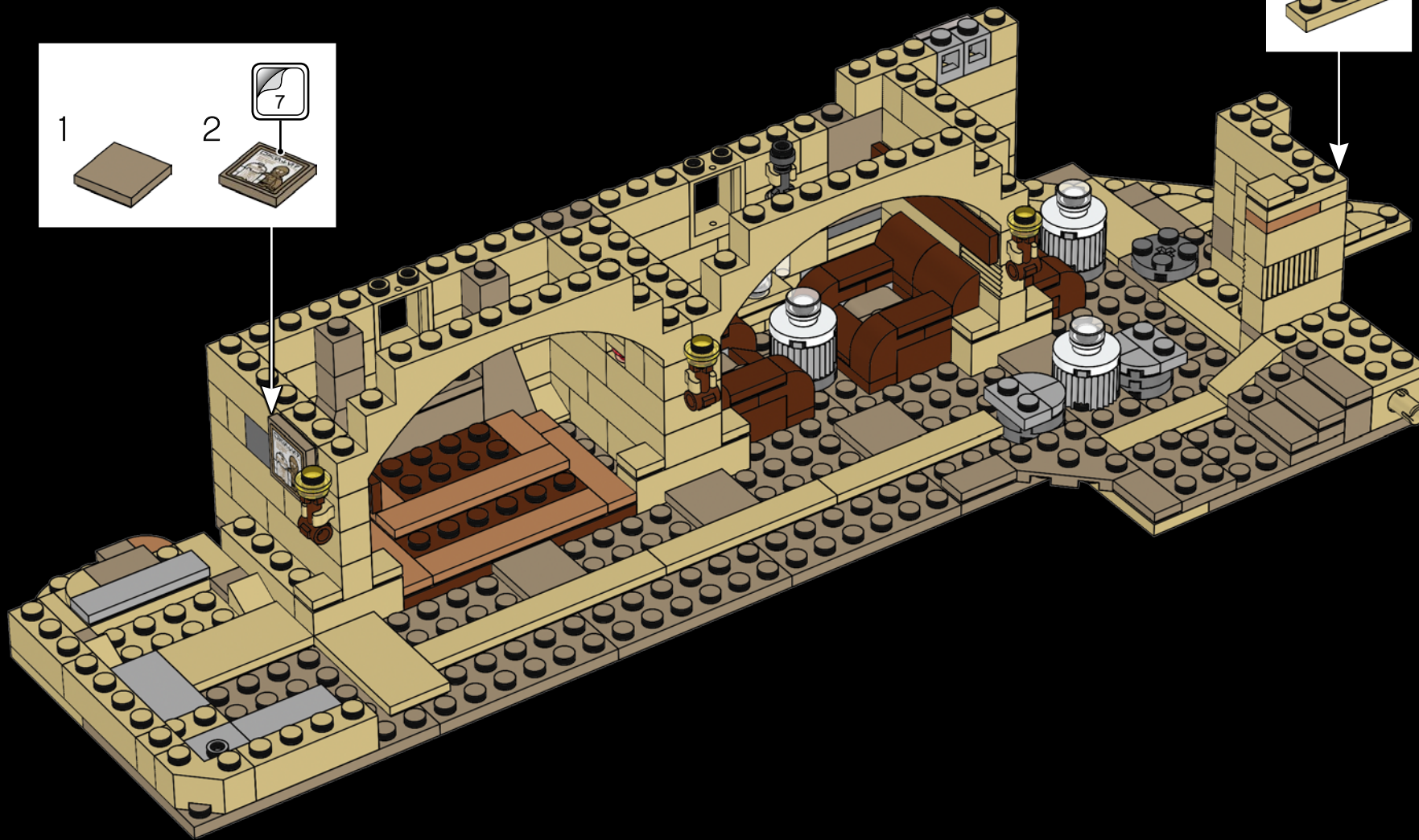
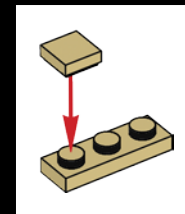
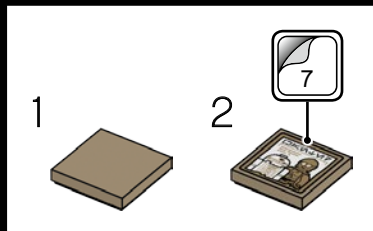

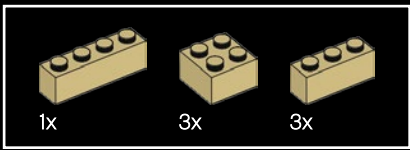

255

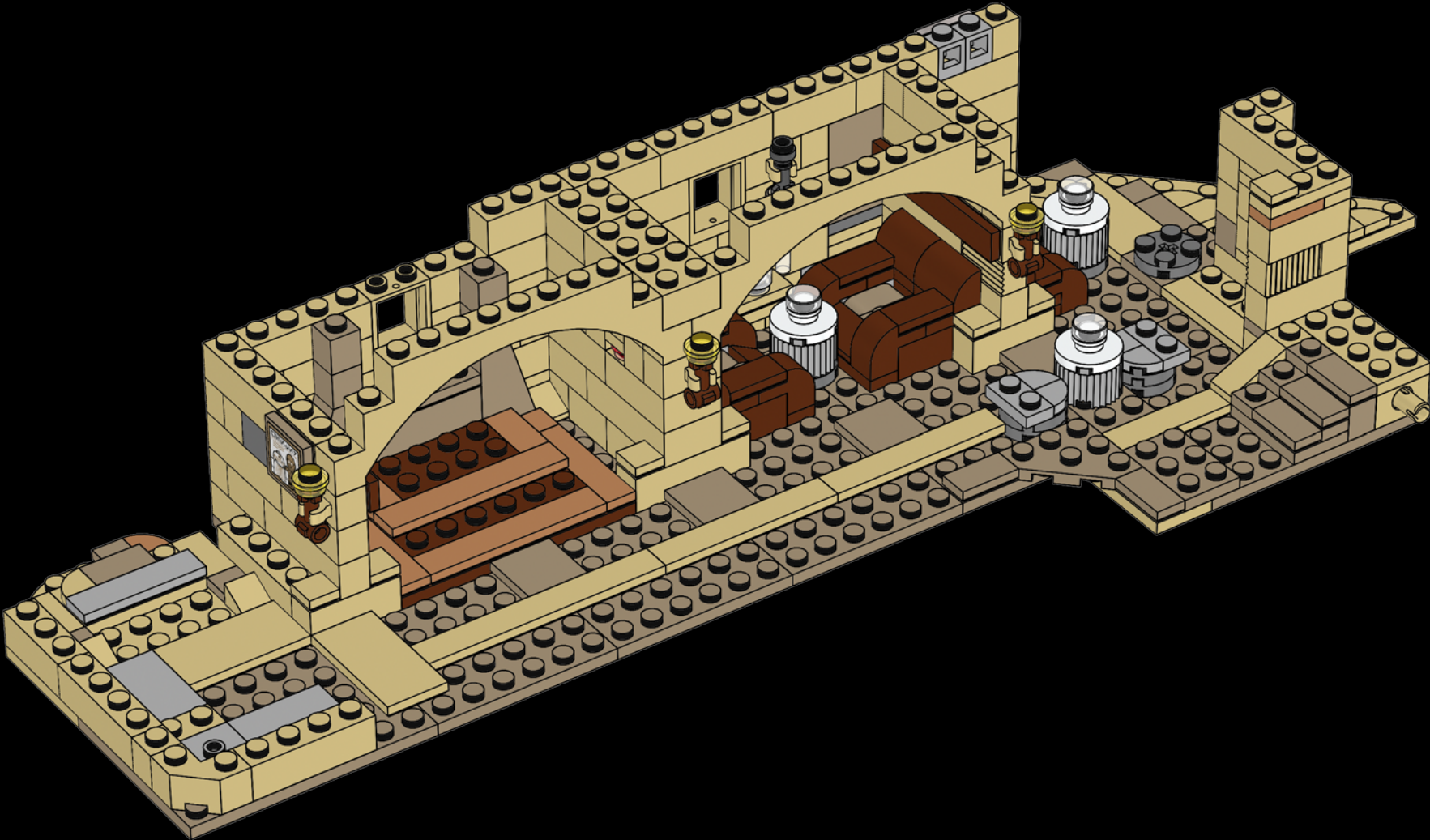

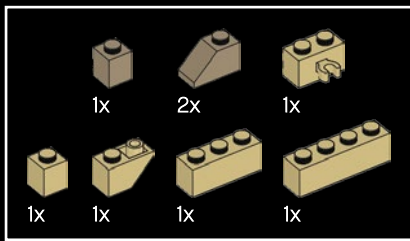

256

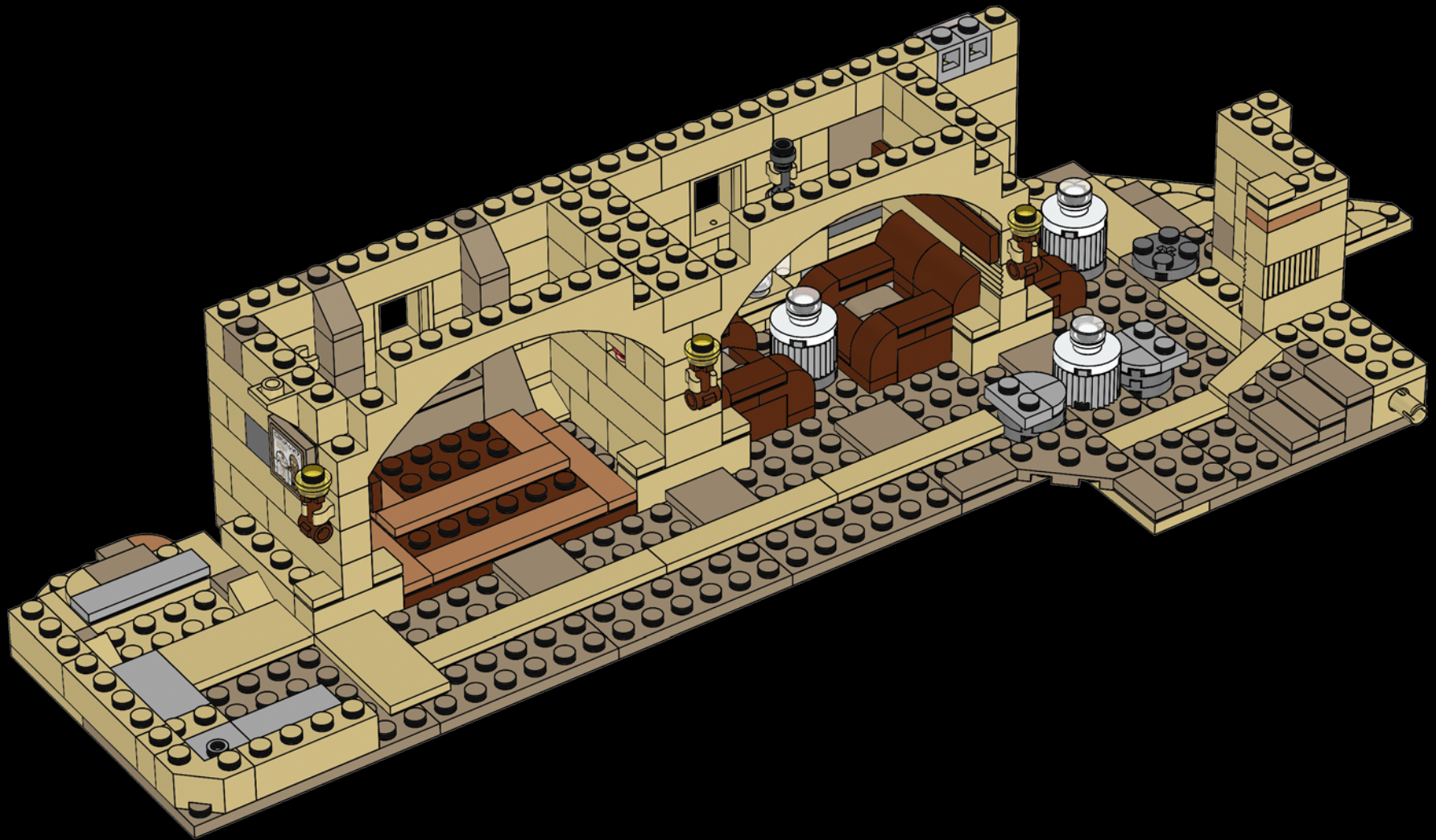

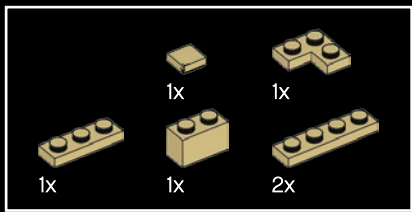

257

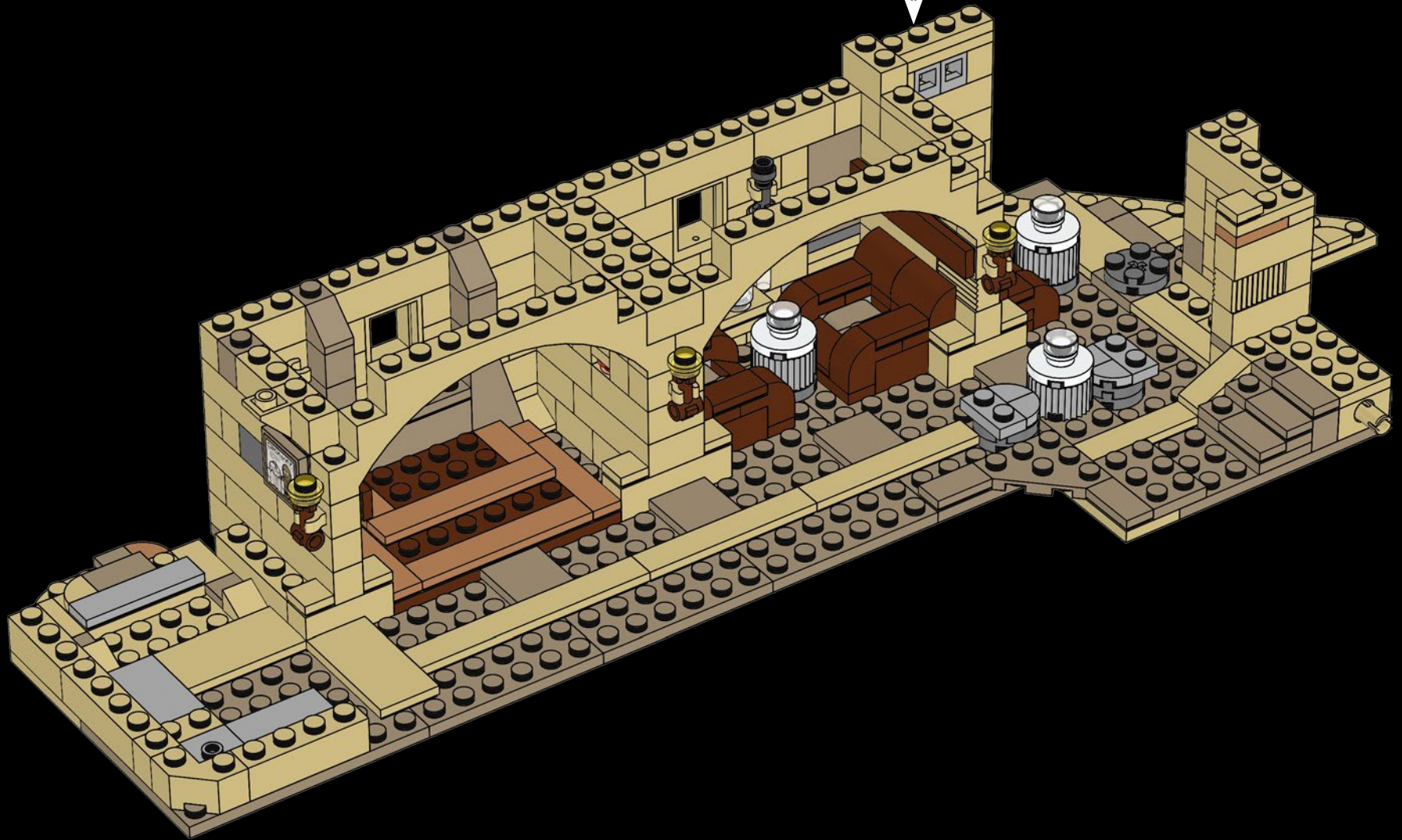
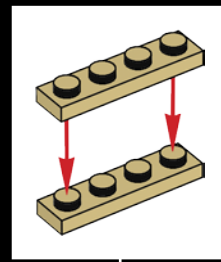

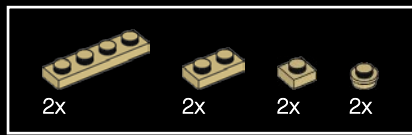

258

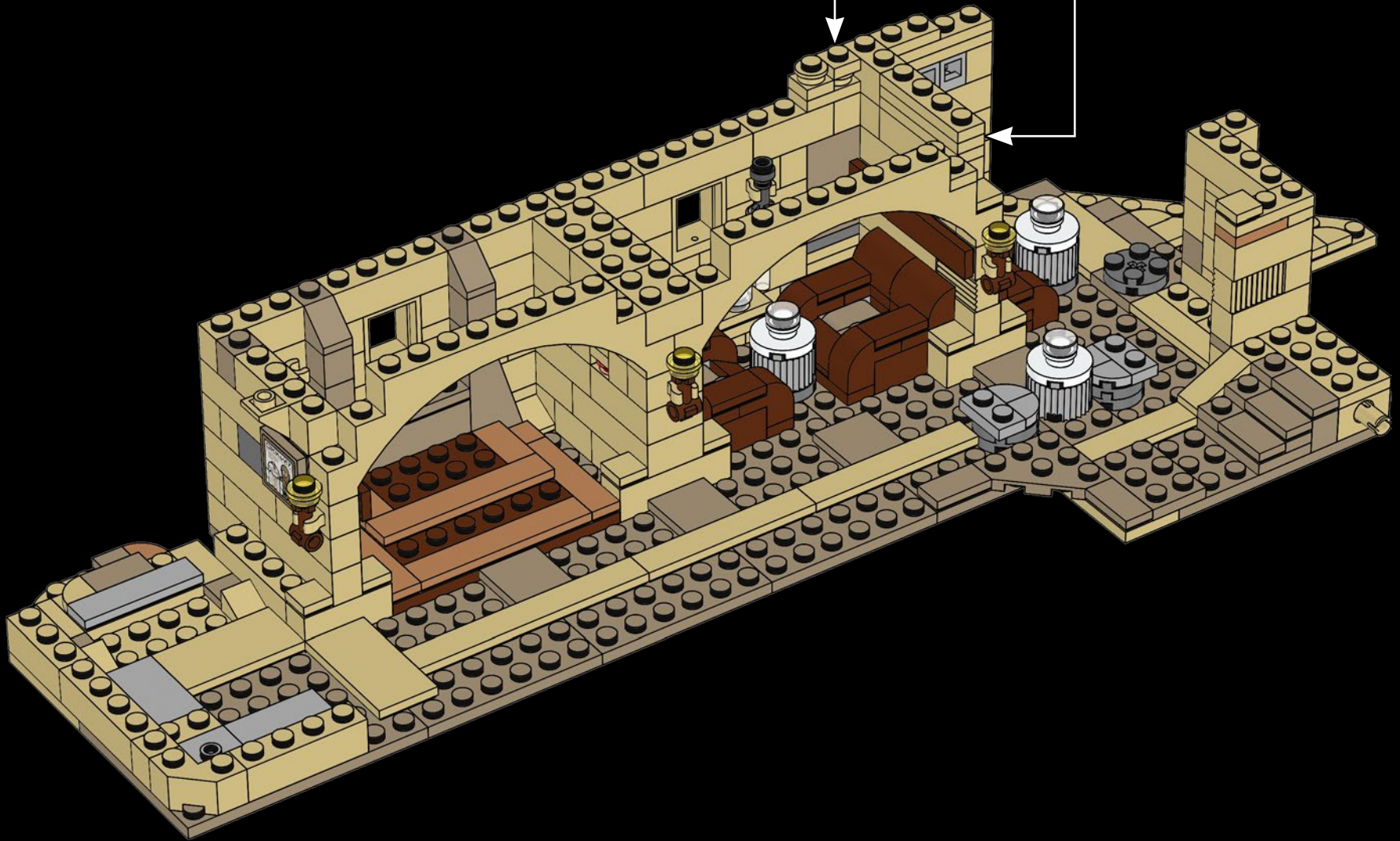
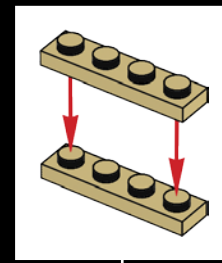
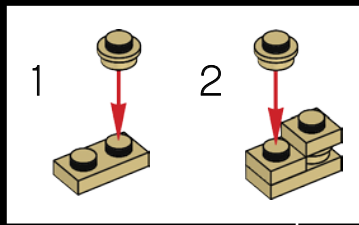

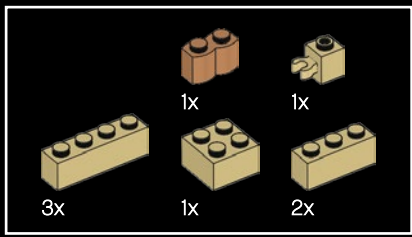

259

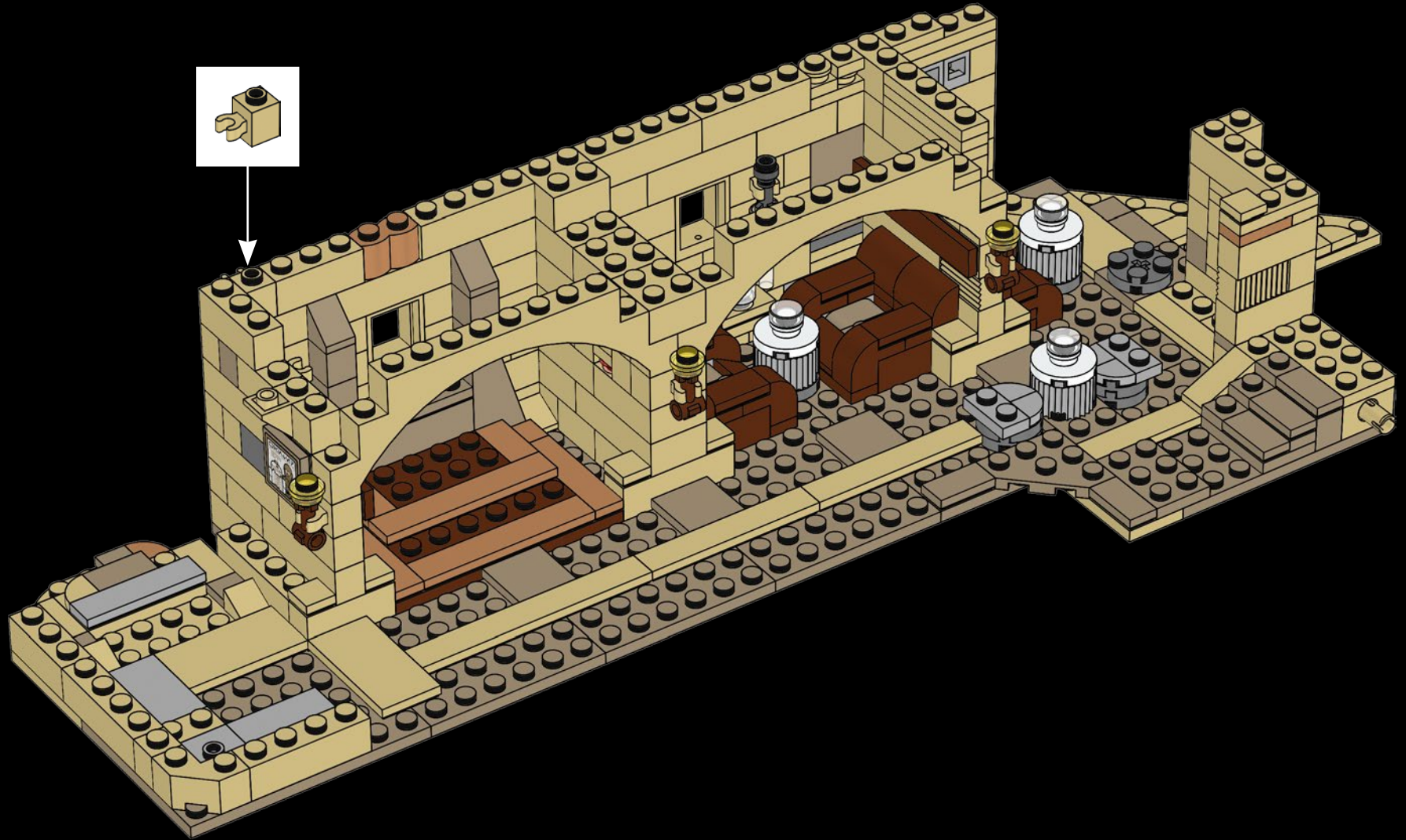

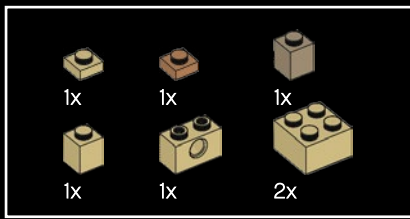

260

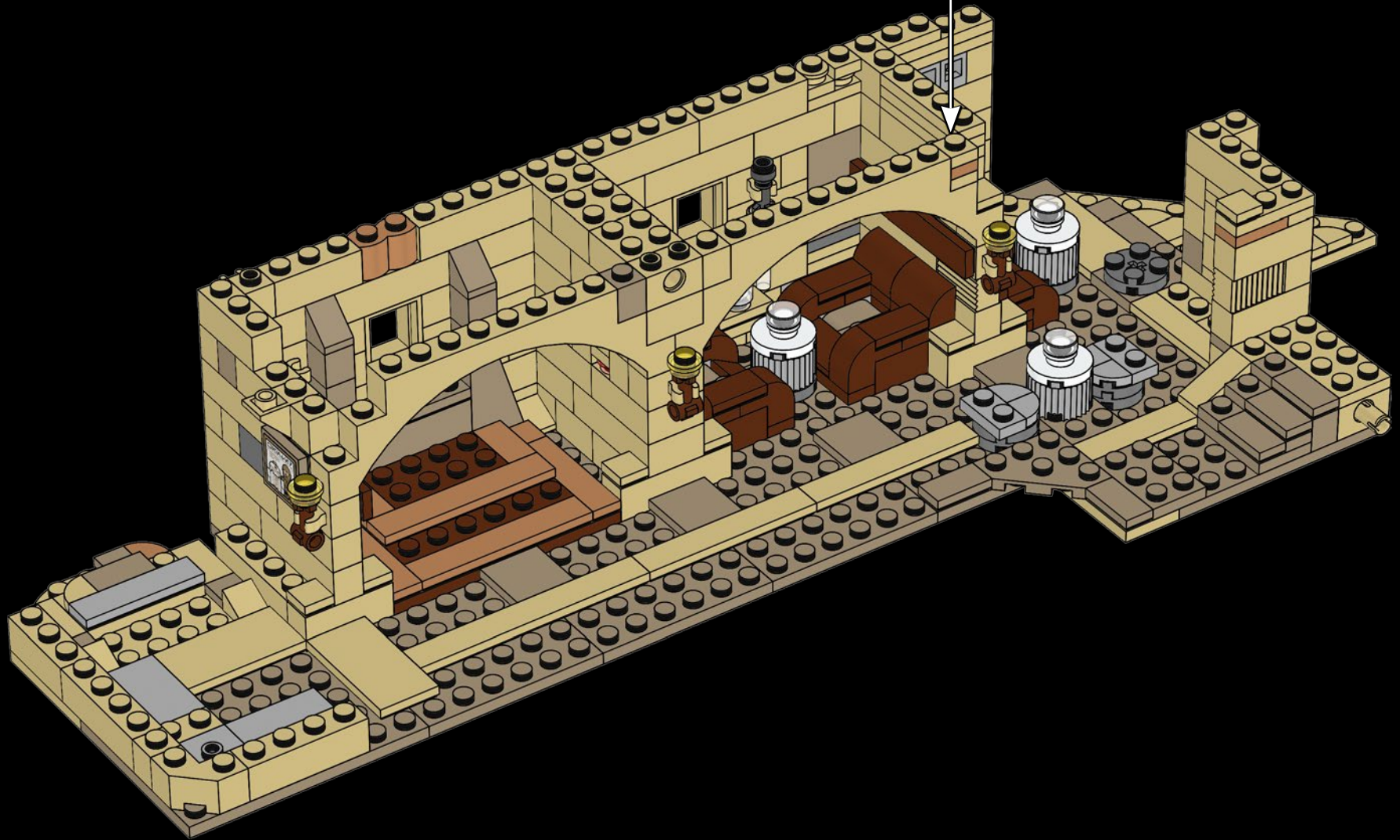
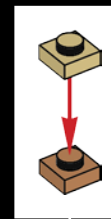

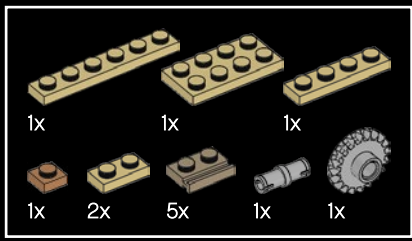

261

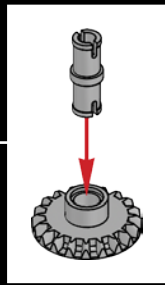
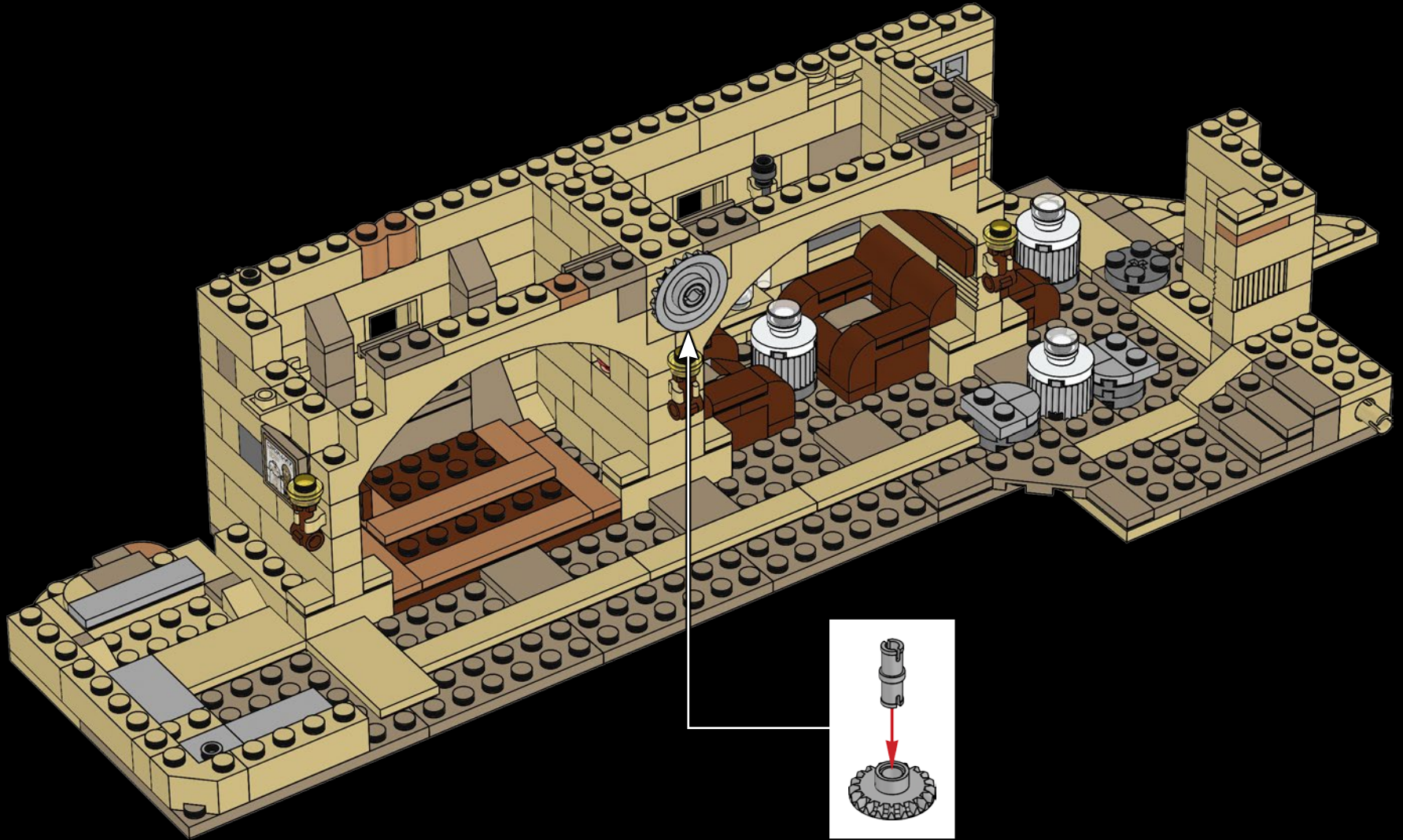

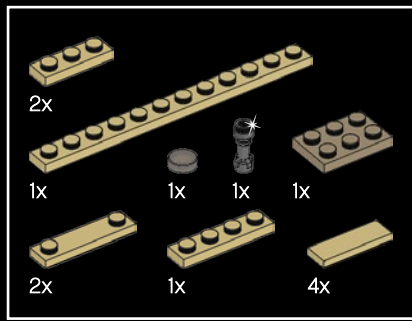

262

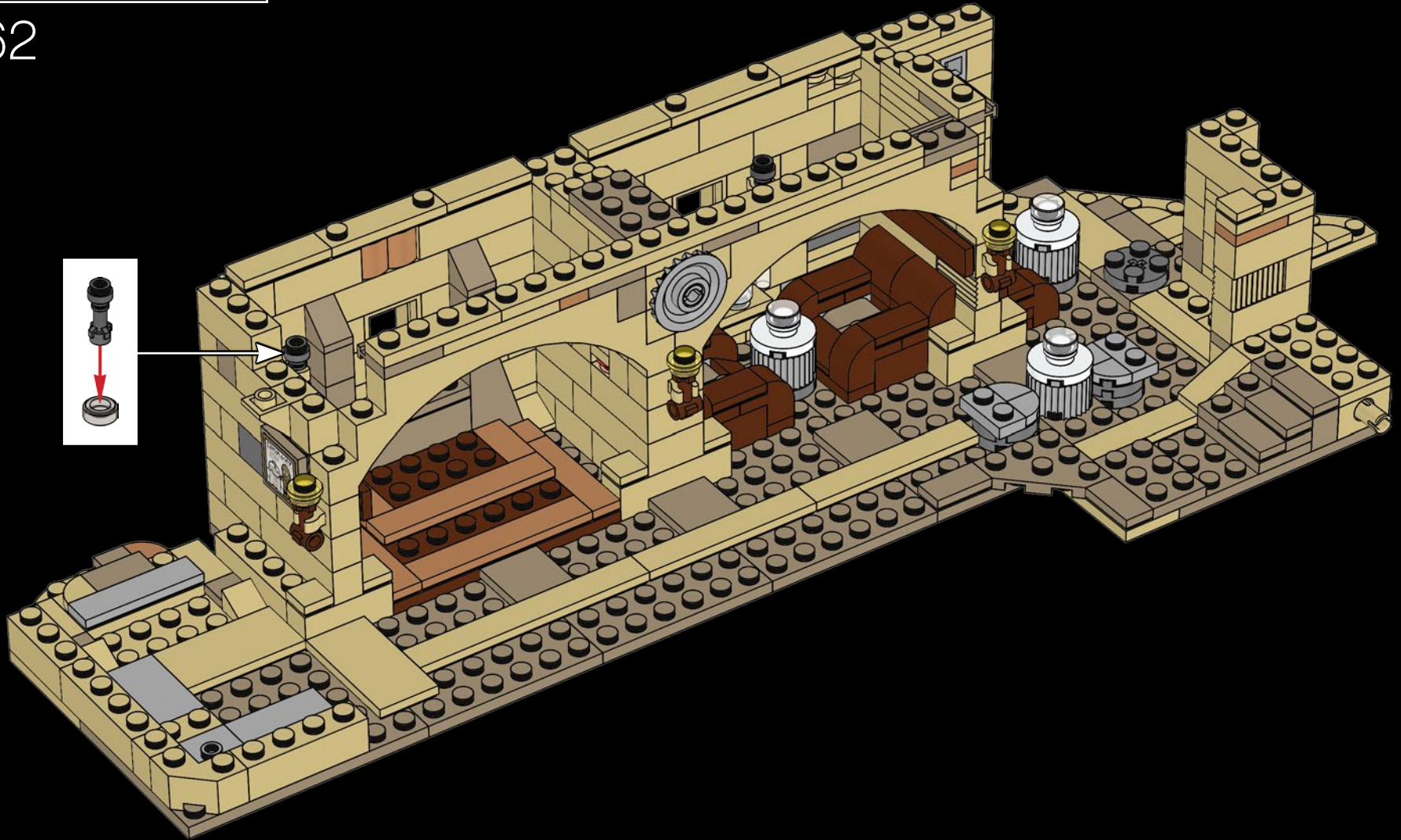
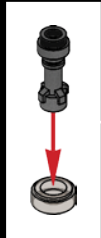

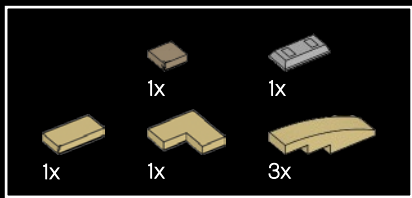

263

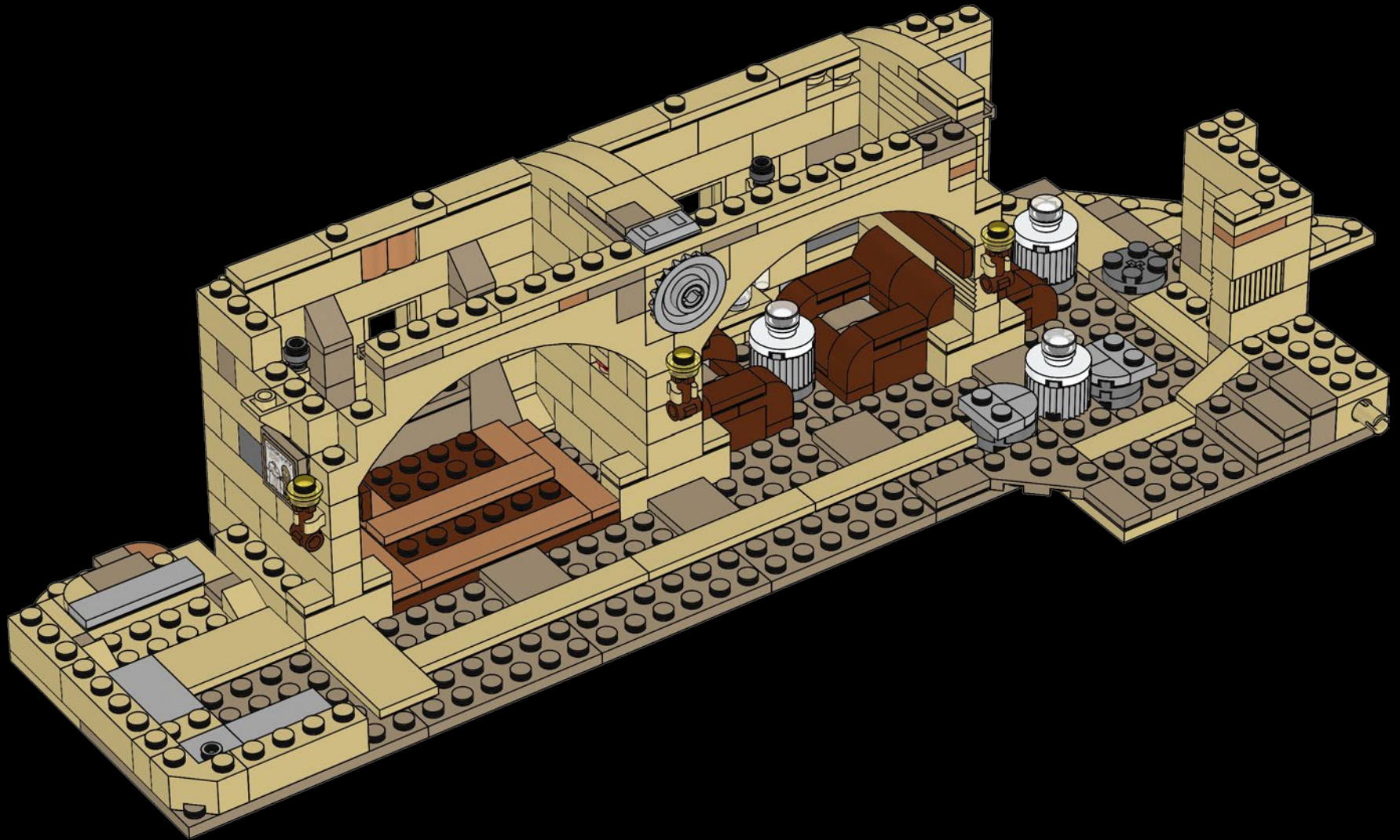

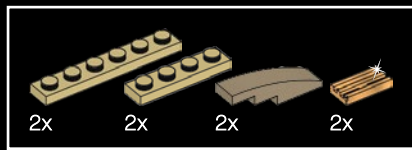

264

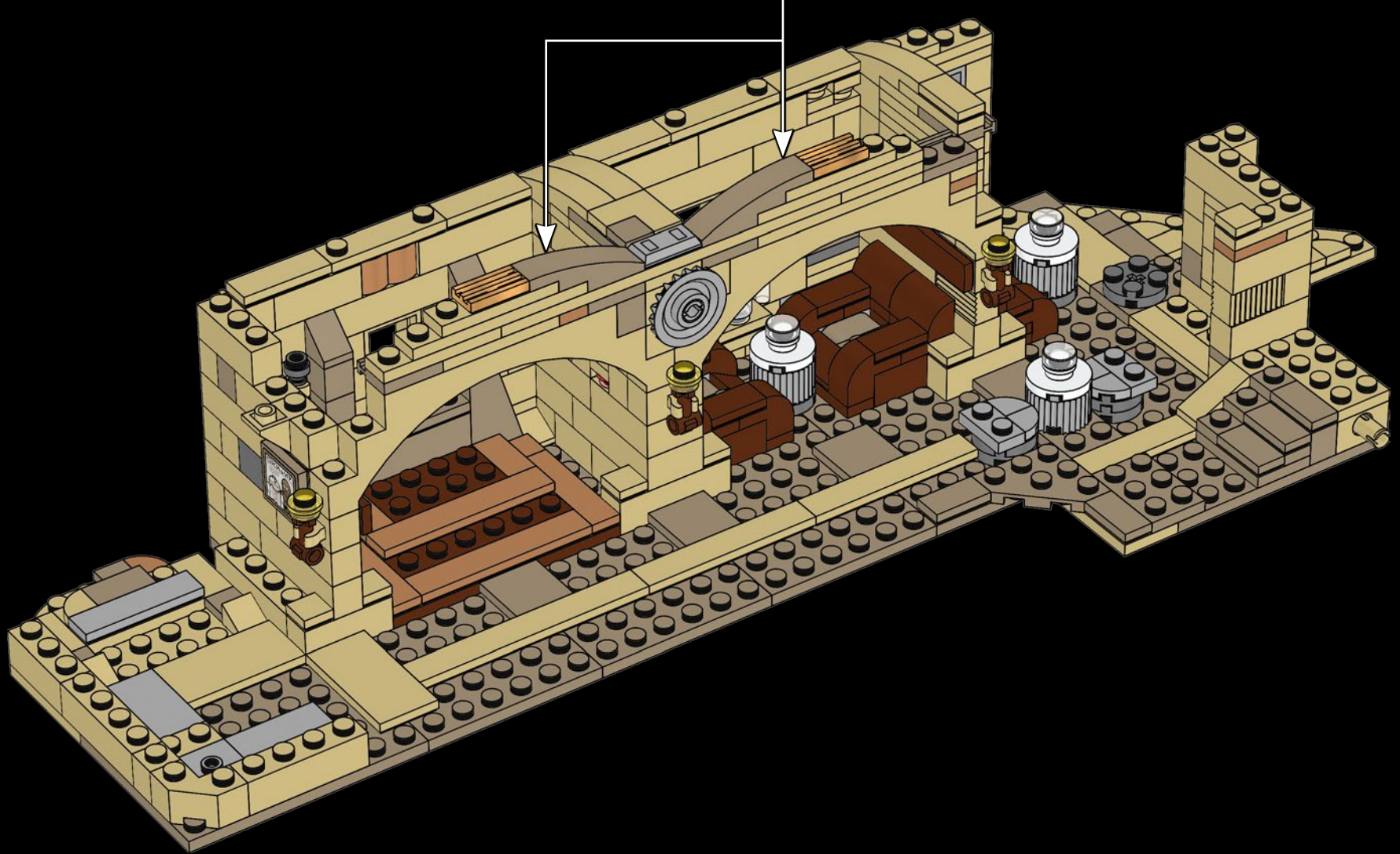
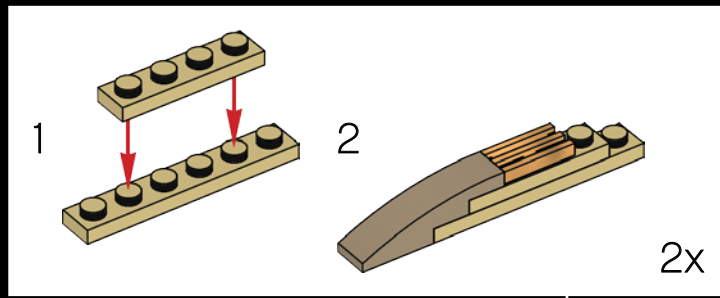



265

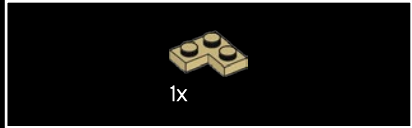
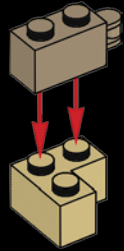

266

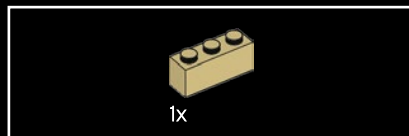
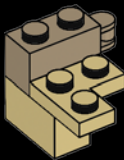

267

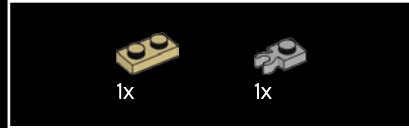
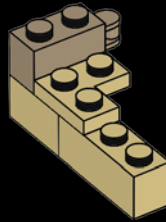

268

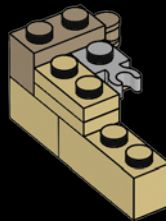

269

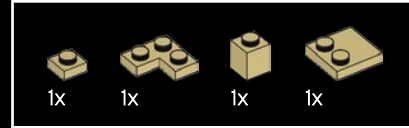
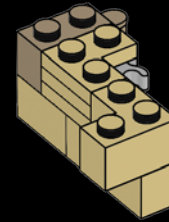

270

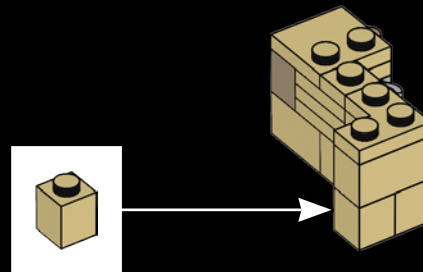

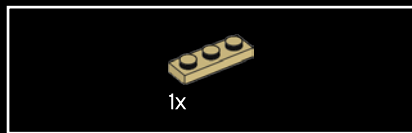

271

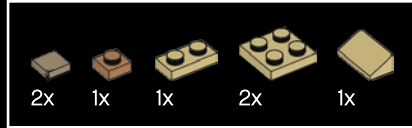
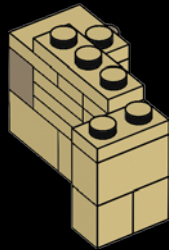

272

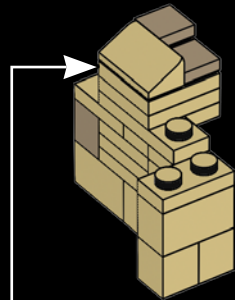
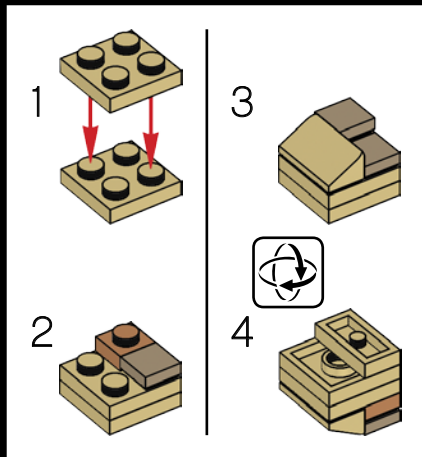

273

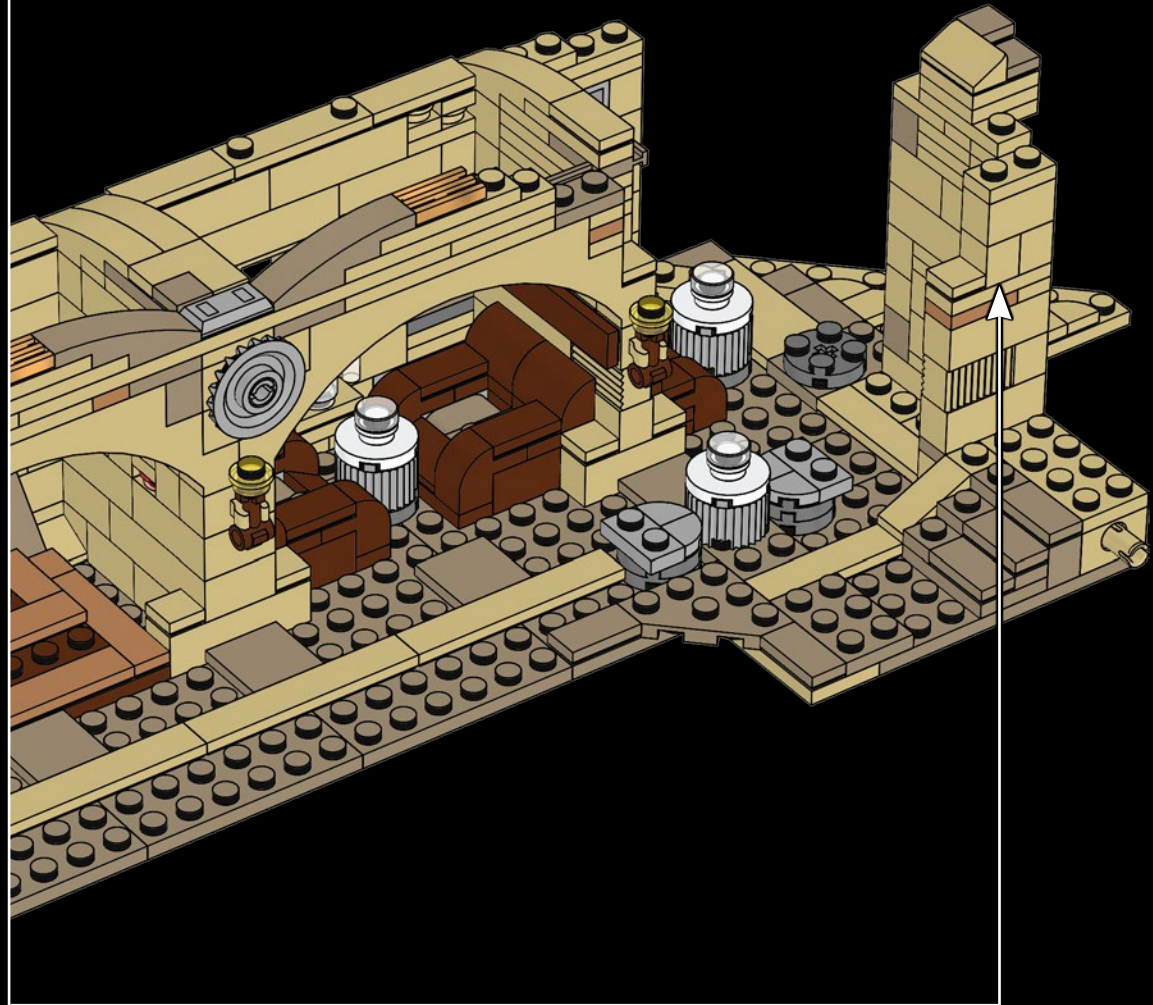

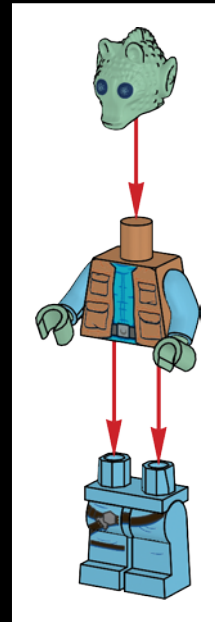
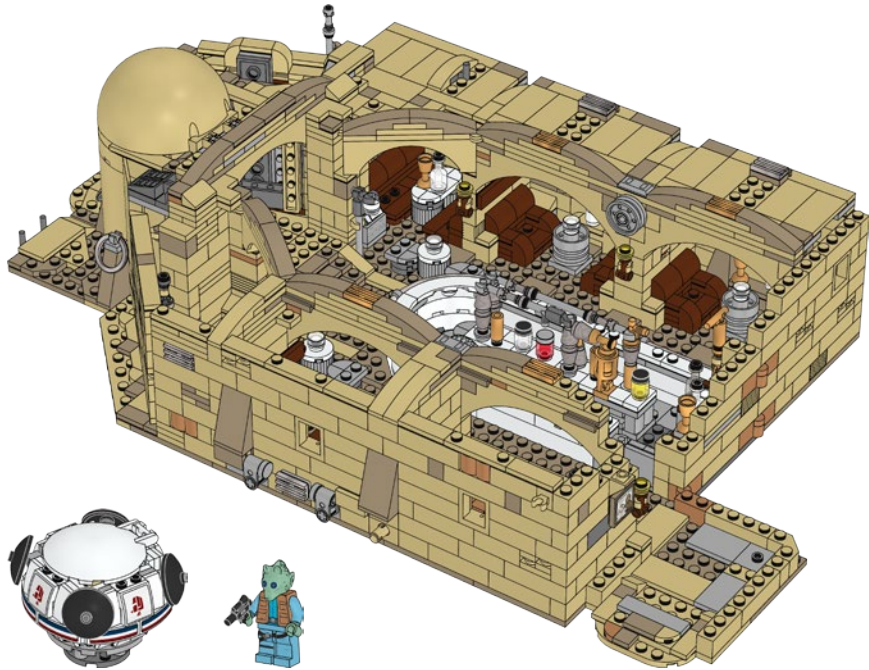
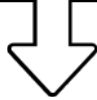

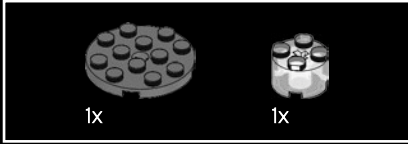

1

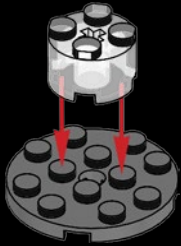

2

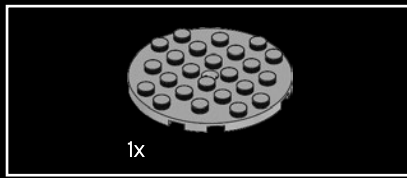

3

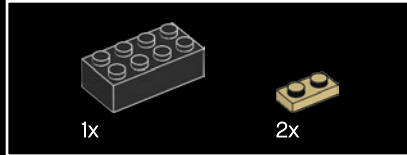
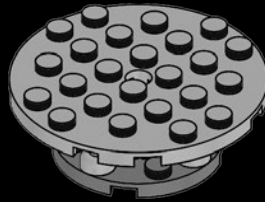

4

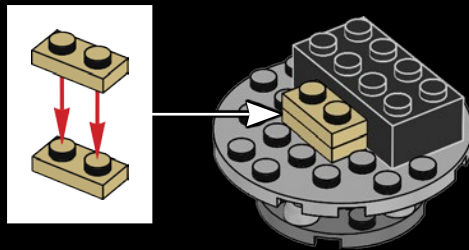

5

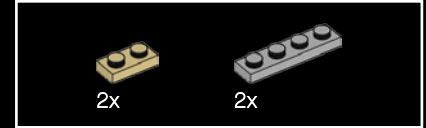
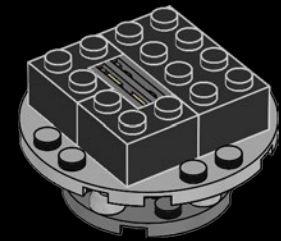

6

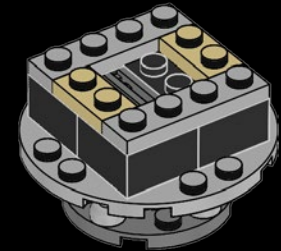



7

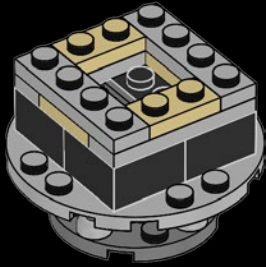

8

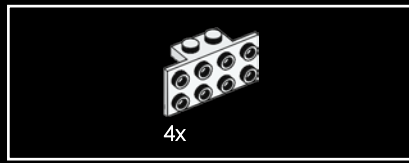
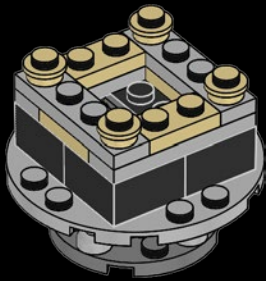

9

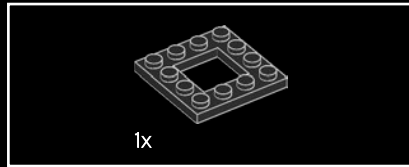
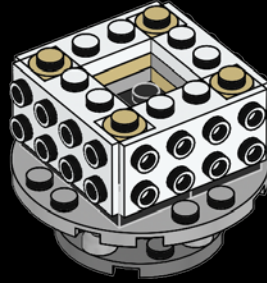

10

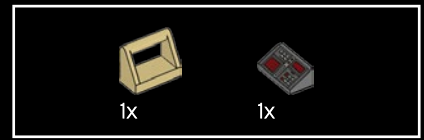
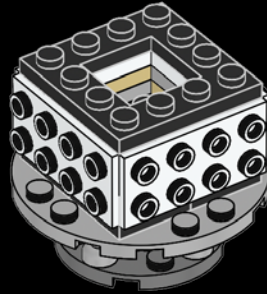

11

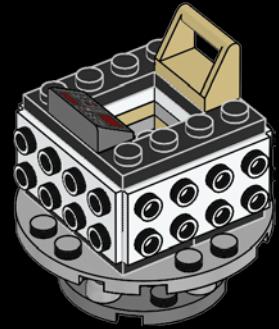

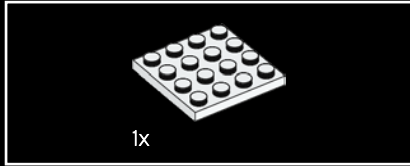

12

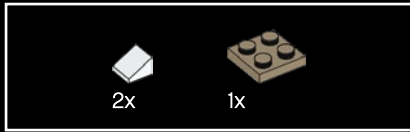

13

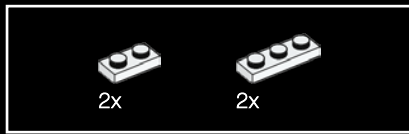
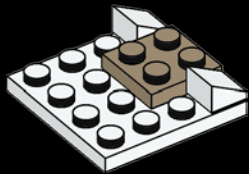

14

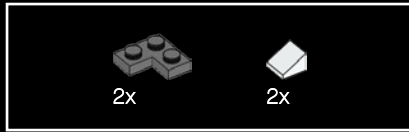

15

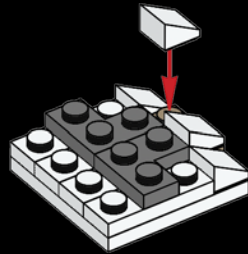

16

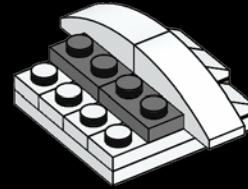

17

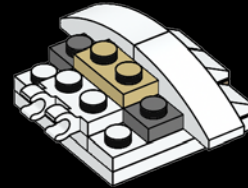

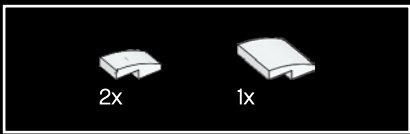

18

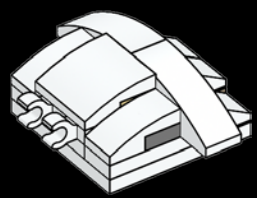

19

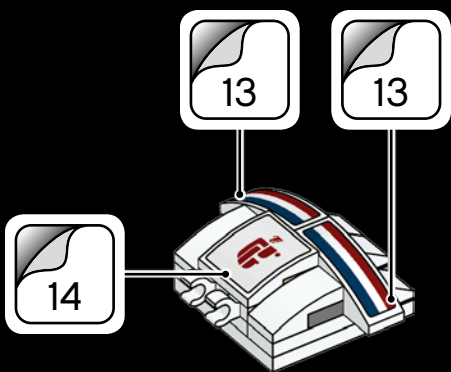

20

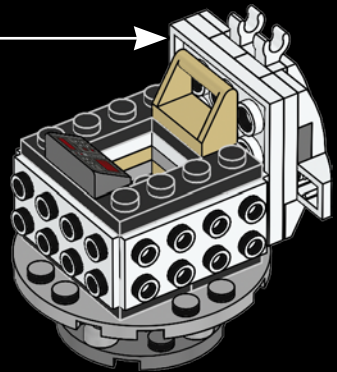

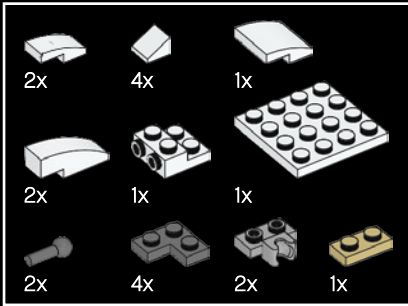
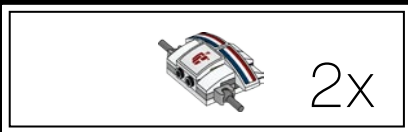

21

1



2



3

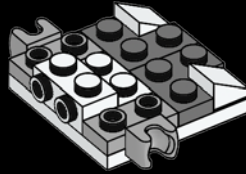

4

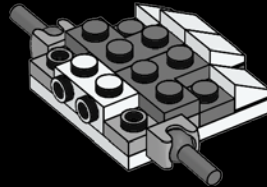

5

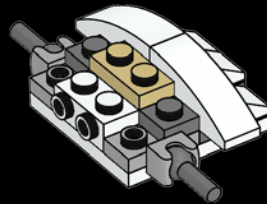

6

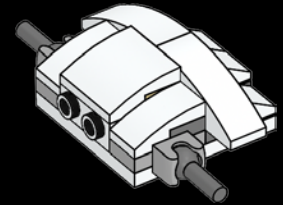

7

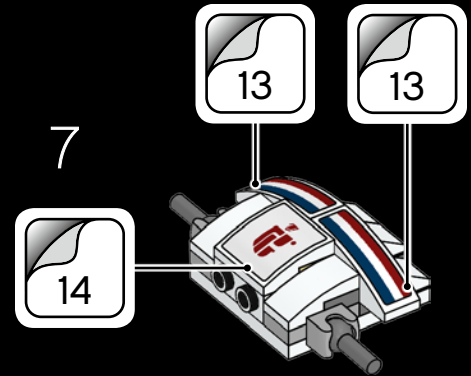

2x

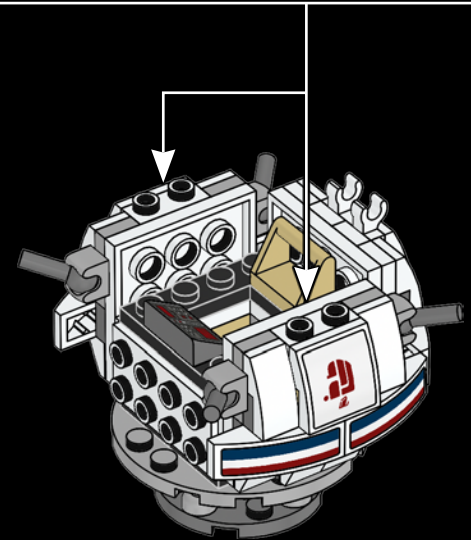

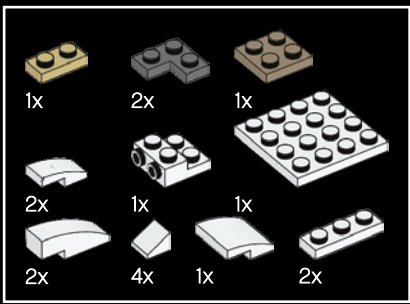

22

1



2

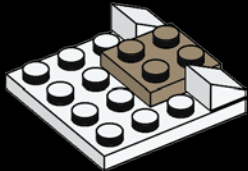

3

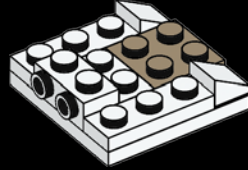

4

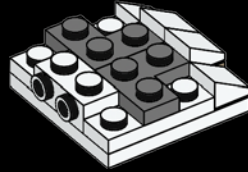

5

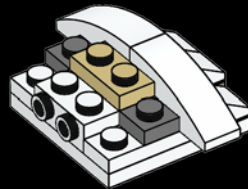

6

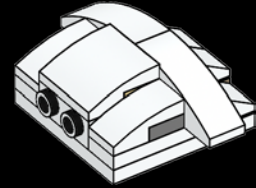

7

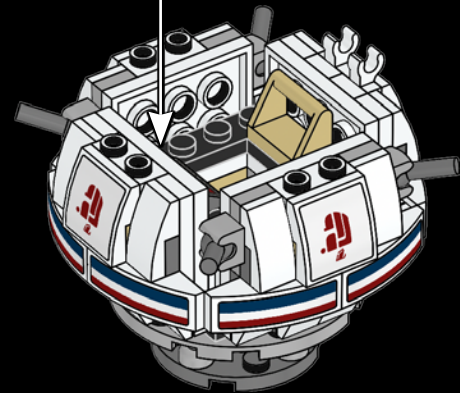
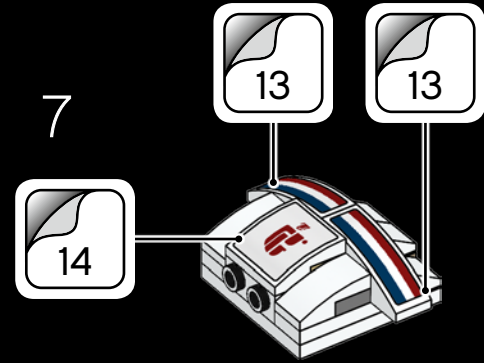



23

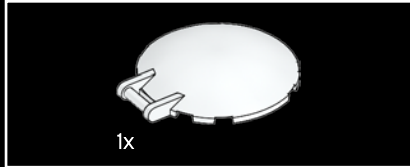
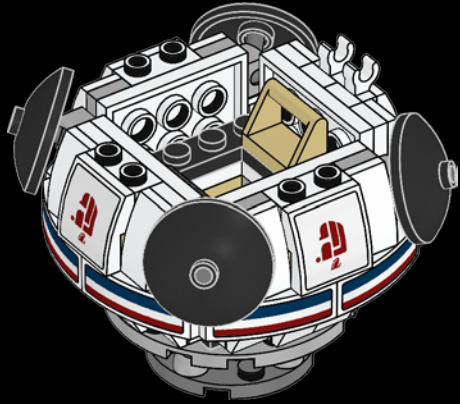

24

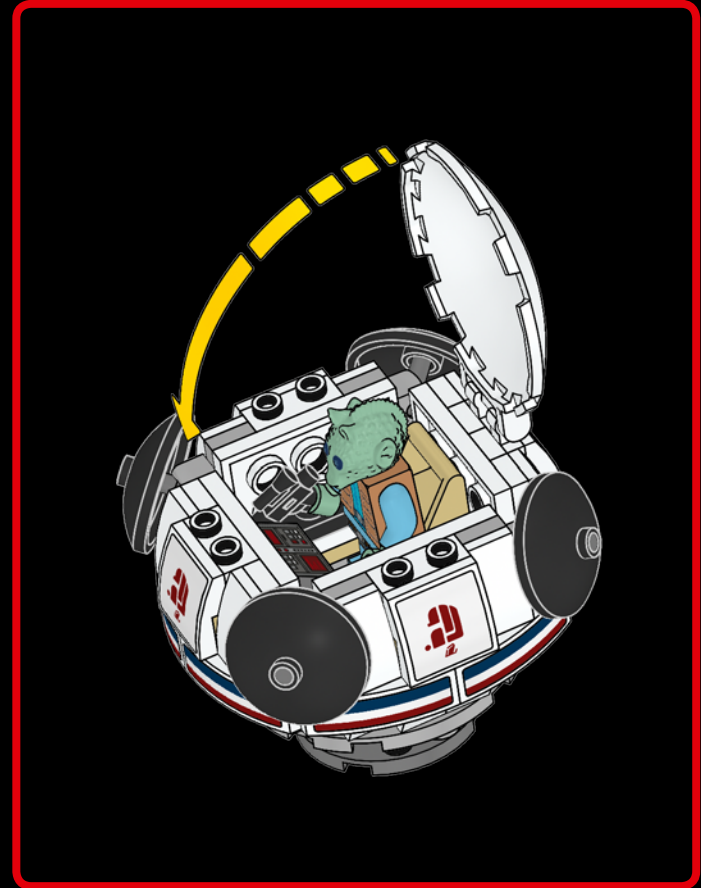
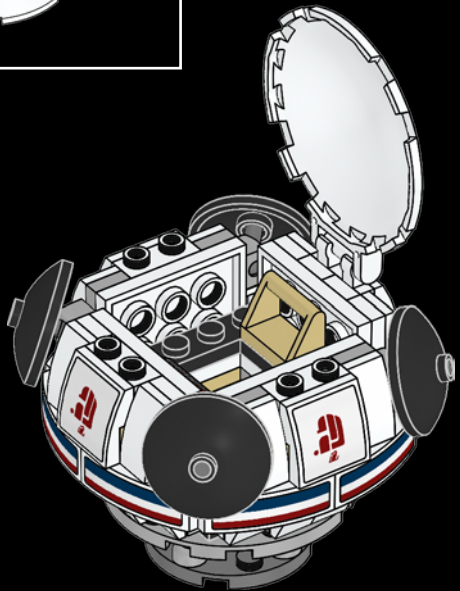

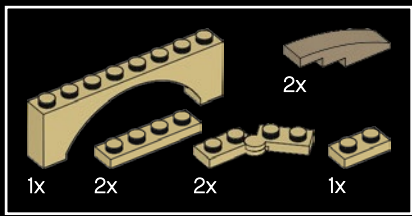

274

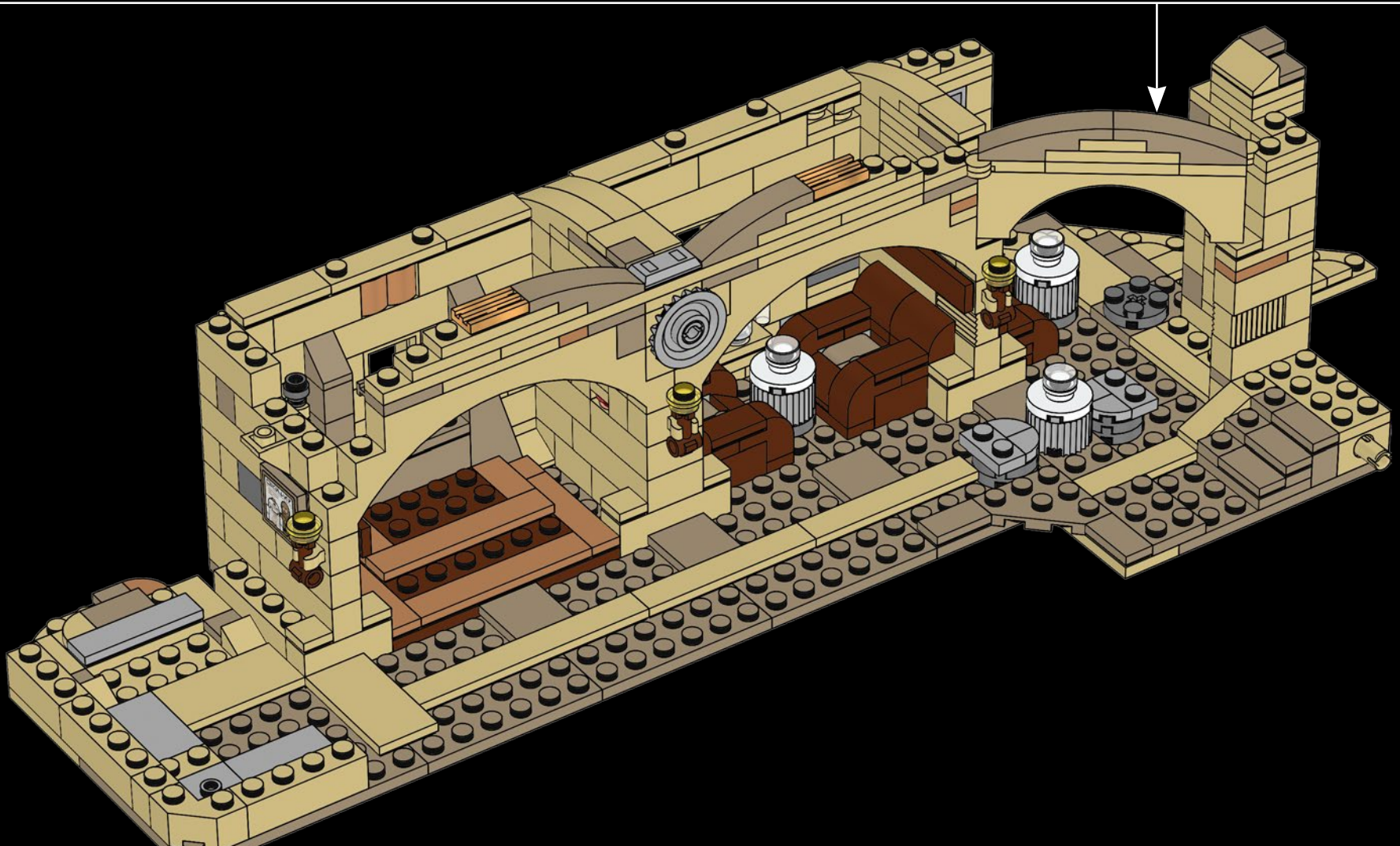
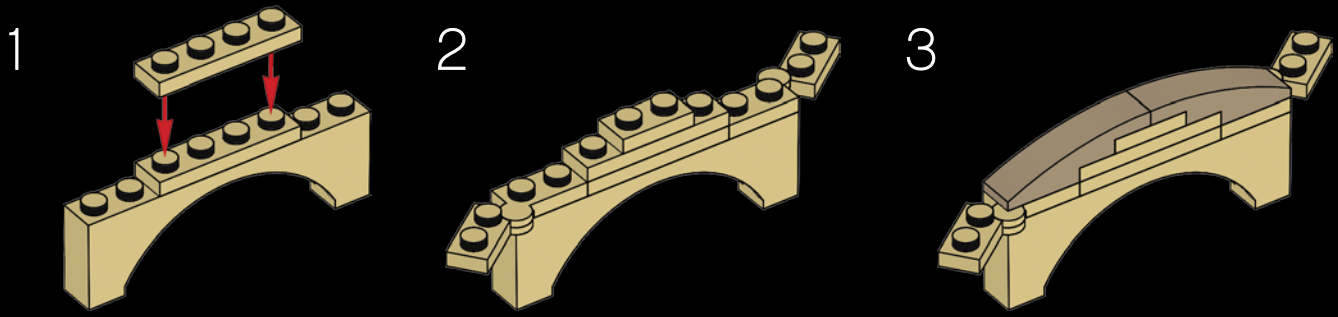



275

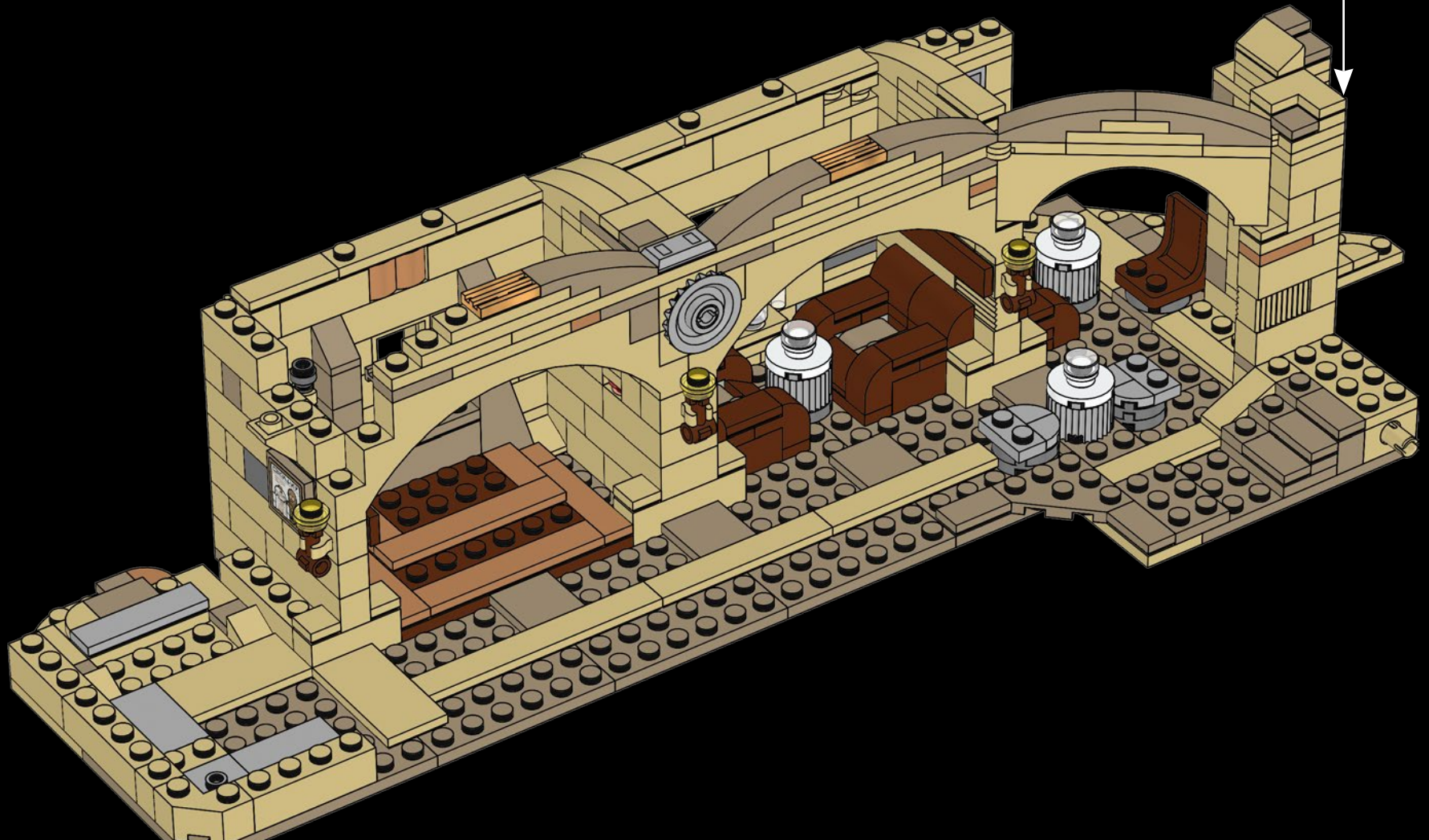
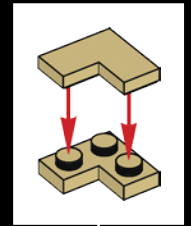

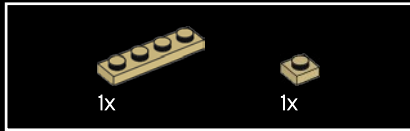
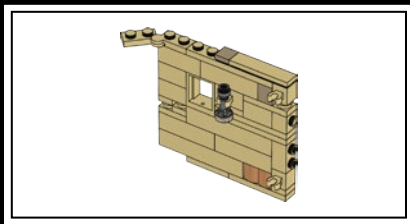

276

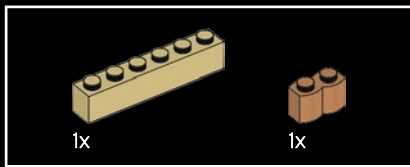
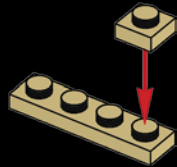

277

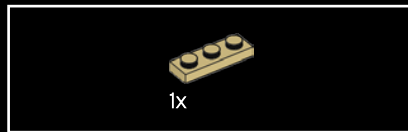
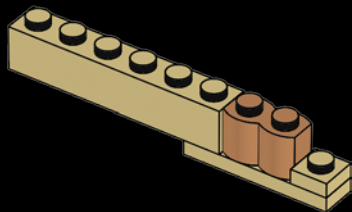

278

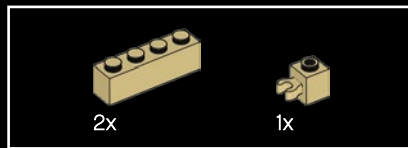
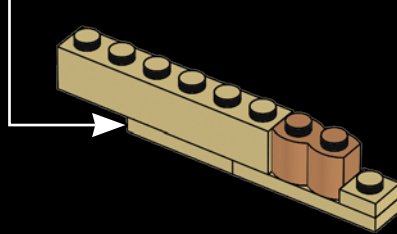
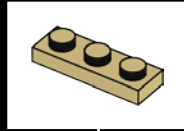

279

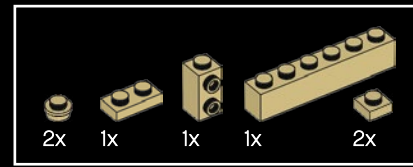
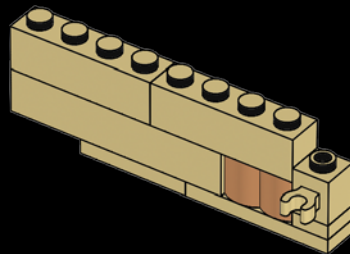

280

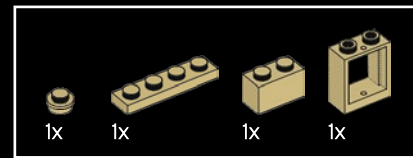
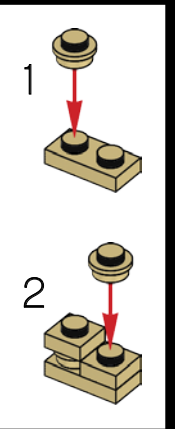
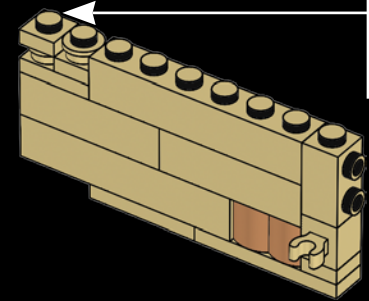

281

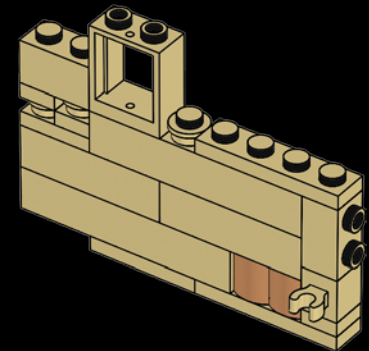

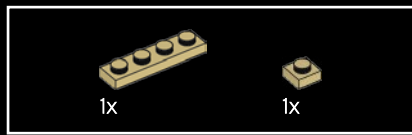

282

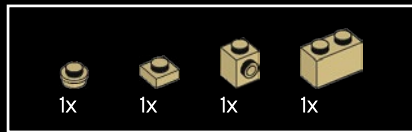
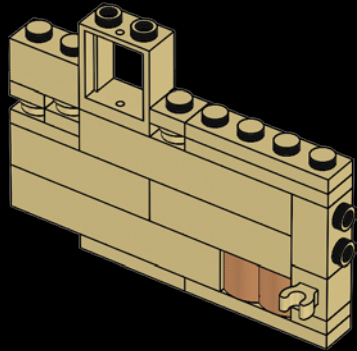

283

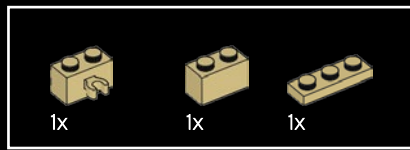
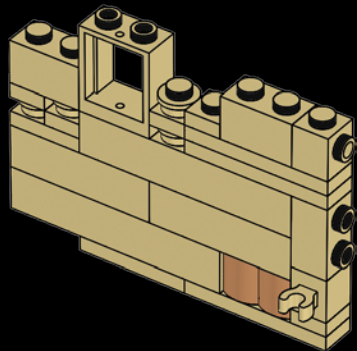

284

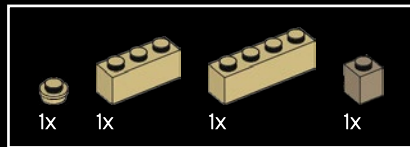
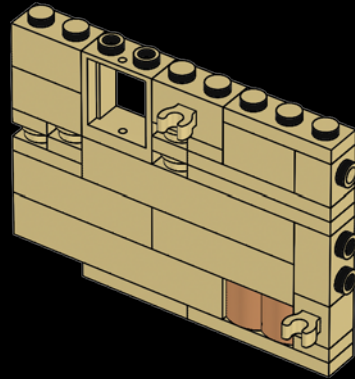

285

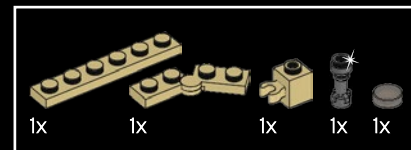
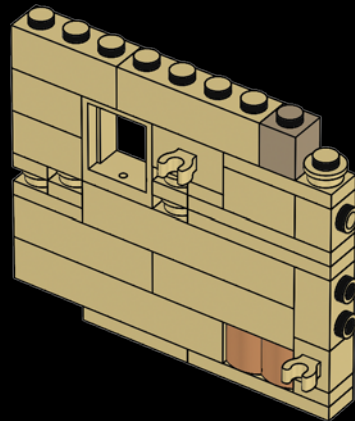

286

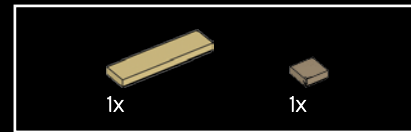
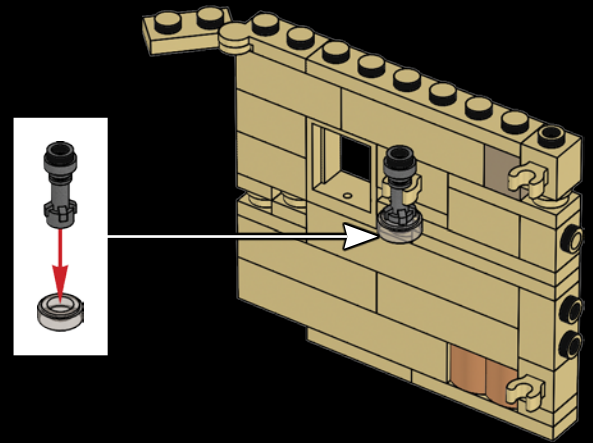

287

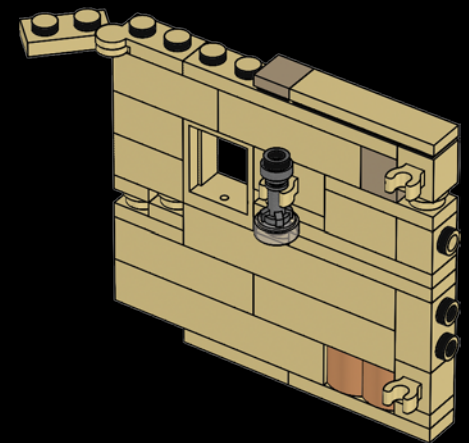

288

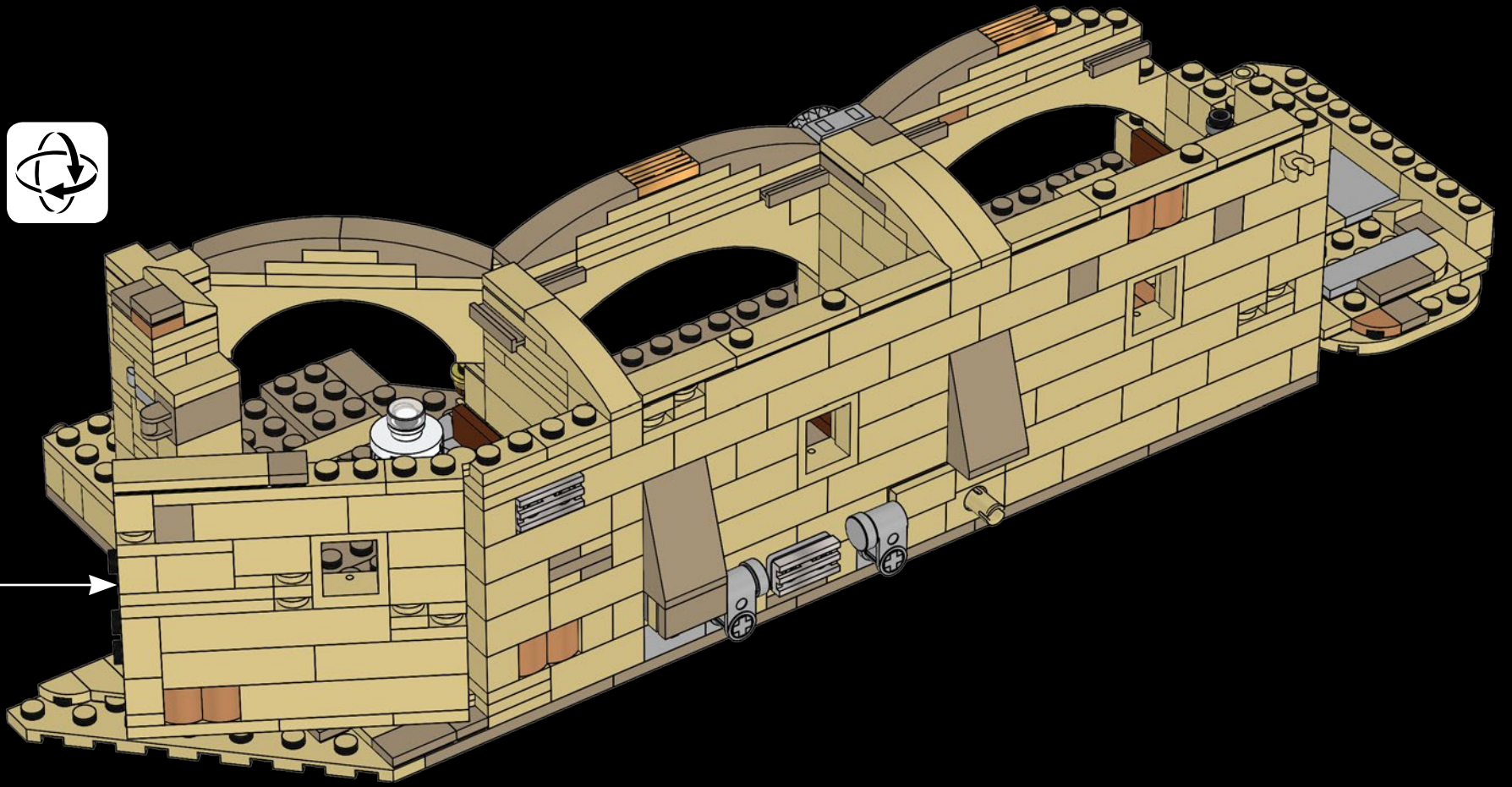

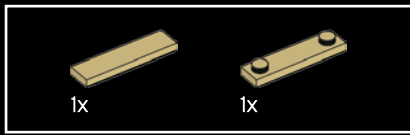

289

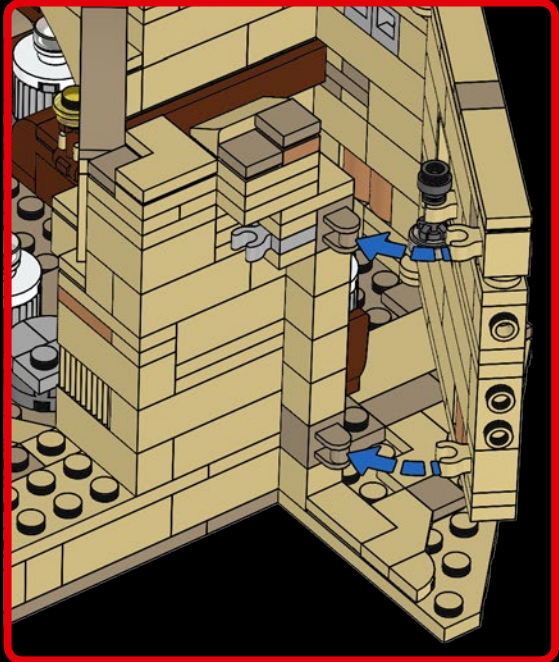
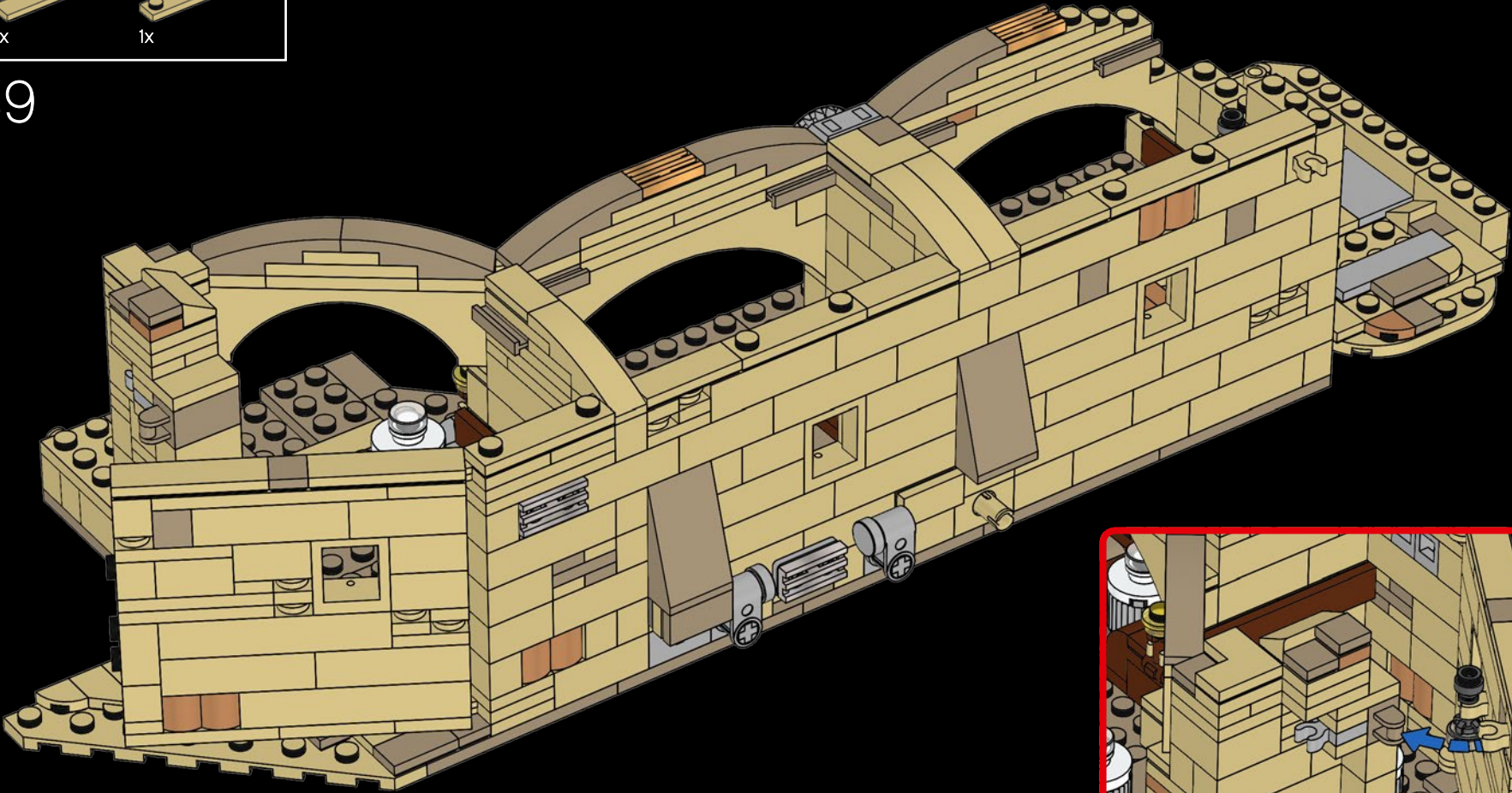

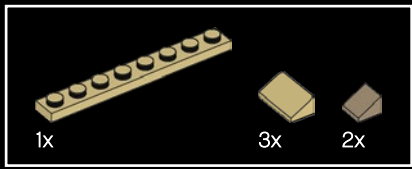

290

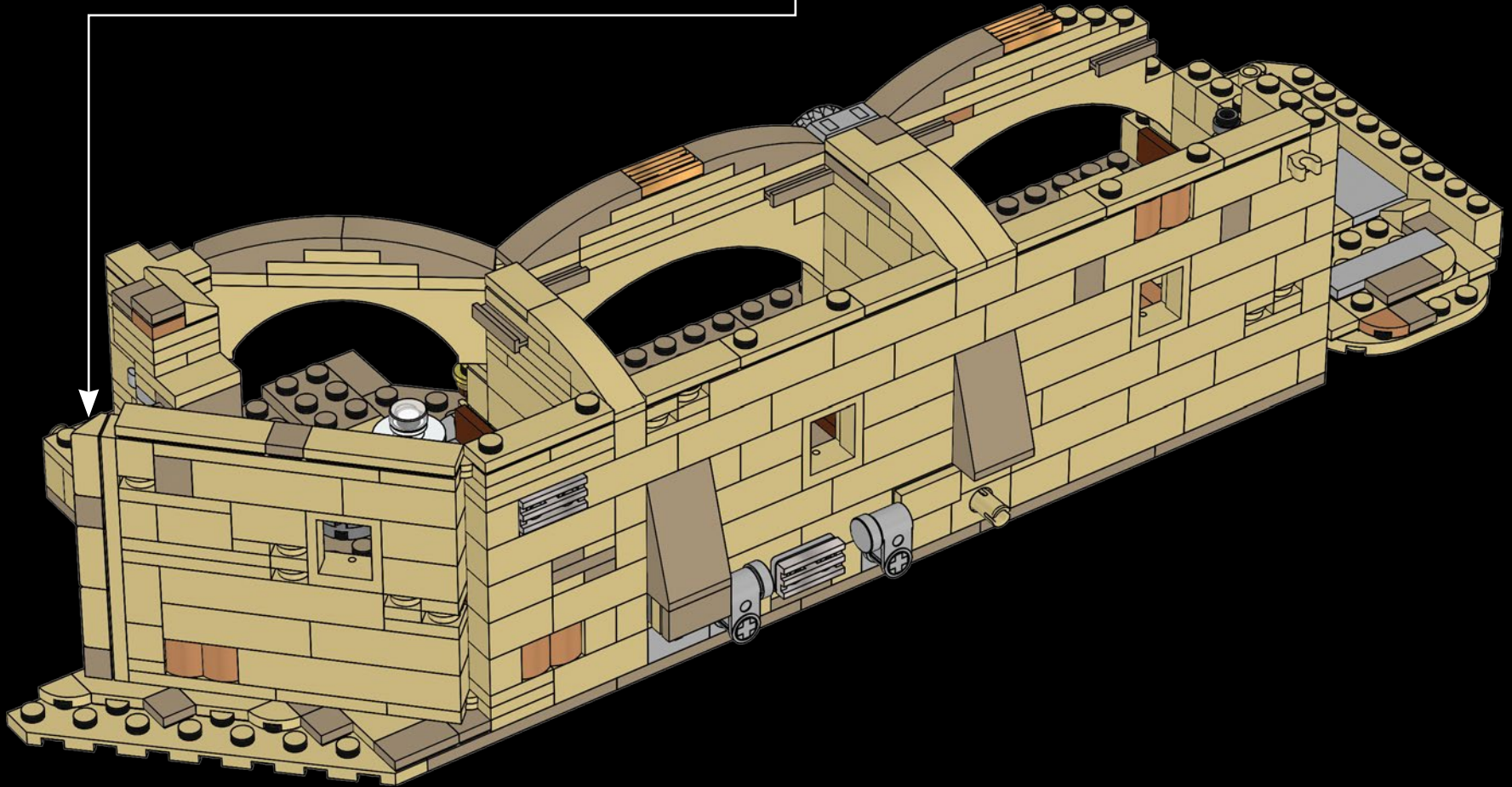
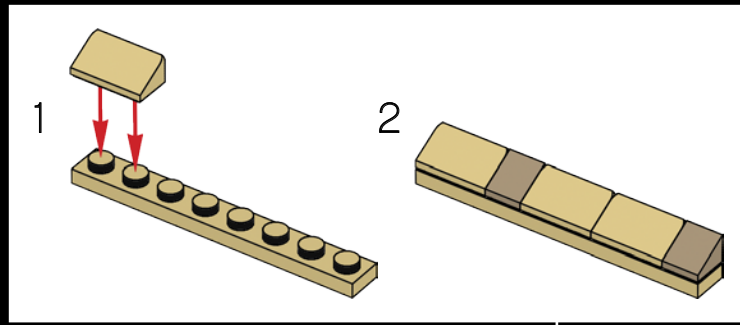

291

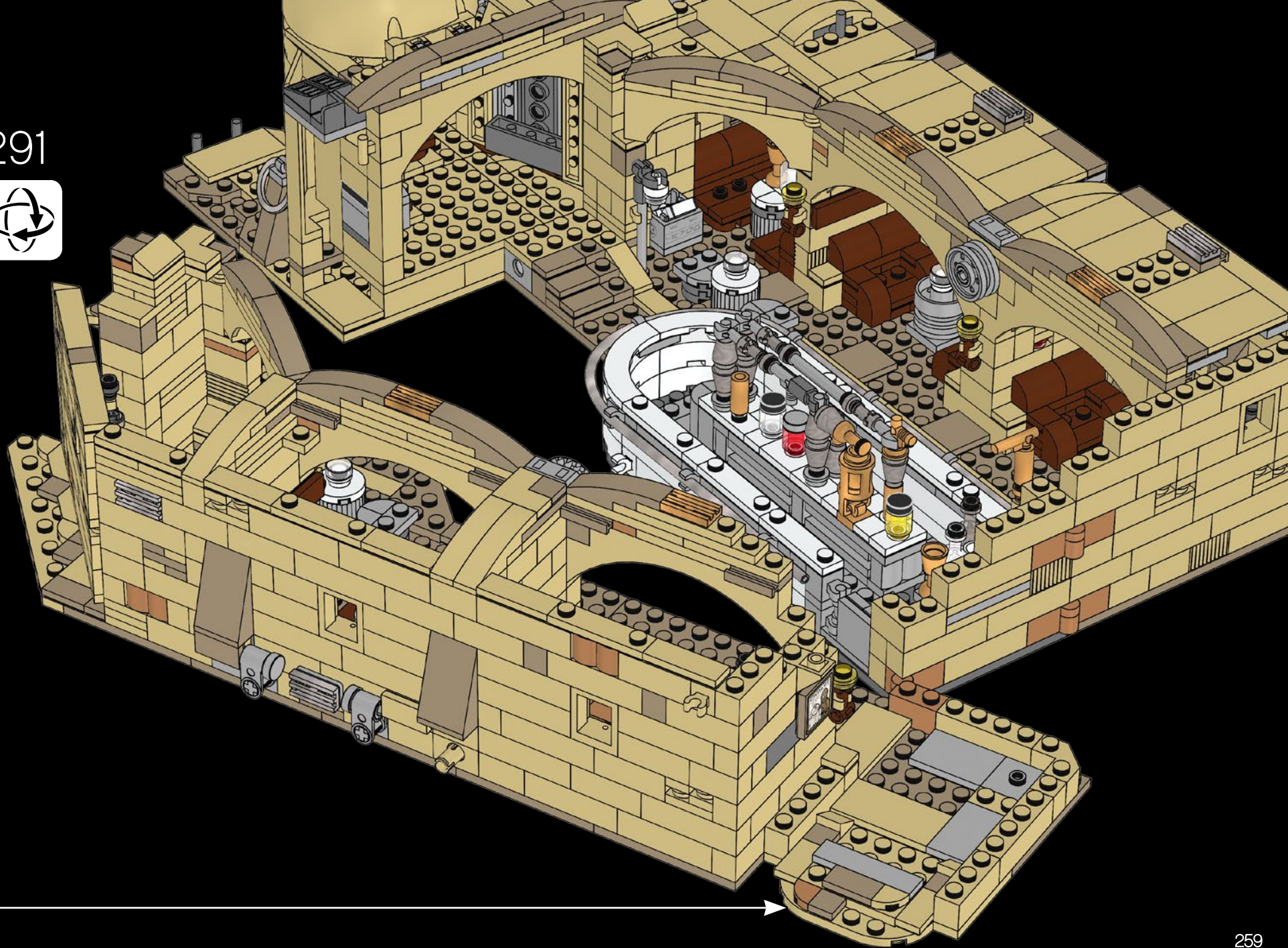

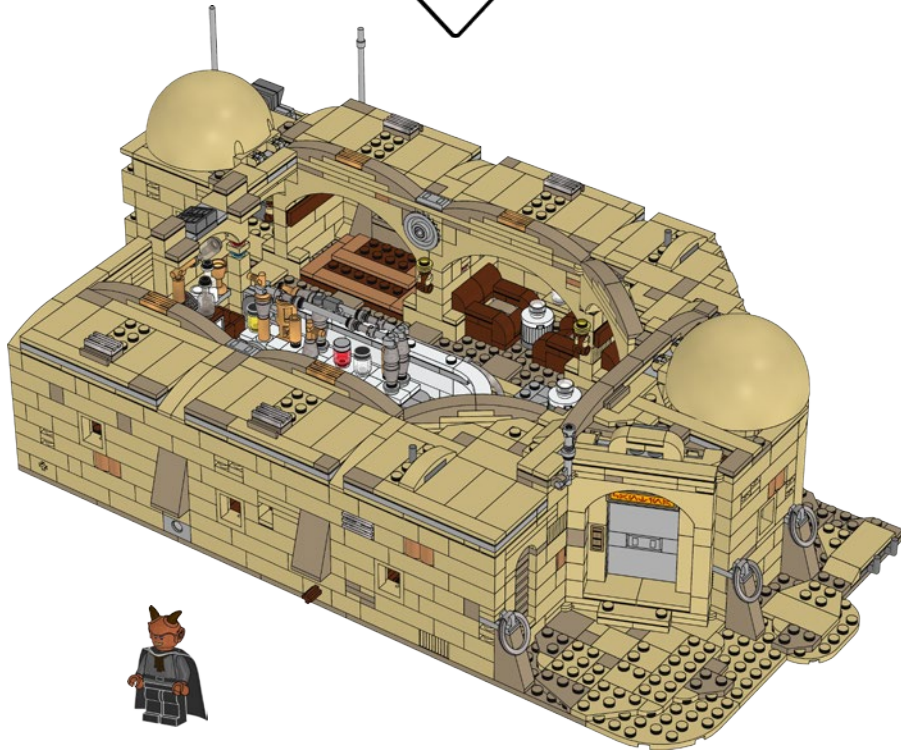
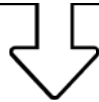
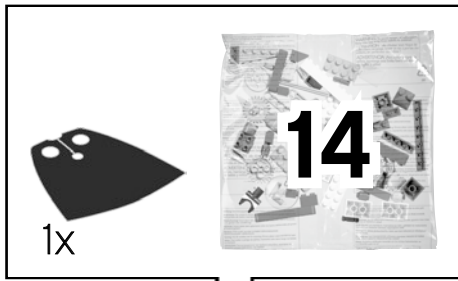

Kardue'Sai'Malloc is a Devaronian with a high bounty on his head. He was a cruel army captain on his home world of Devaron and committed deadly crimes. Now he is trying to escape his past by hiding on Tatooine and going by the alias "Labria."

Kardue'Sai'Malloc est un Devaronien dont la tête a été mise à fort prix. Il était un capitaine d'armée cruel sur Devaron, sa planète natale, et a commis des crimes meurtriers. Maintenant, il essaie d'échapper à son passé en se cachant sur Tatooine et en prenant le pseudonyme de « Labria ».

Kardue'Sai'Malloc es un Devaroniano por cuya cabeza se paga un alto precio. Era un cruel capitán en el ejército de su mundo natal, Devaron, y cometió crímenes capitales. Ahora trata de escapar de su pasado escondiéndose en Tatooine, haciéndose llamar Labria.

1

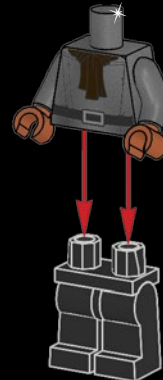

2

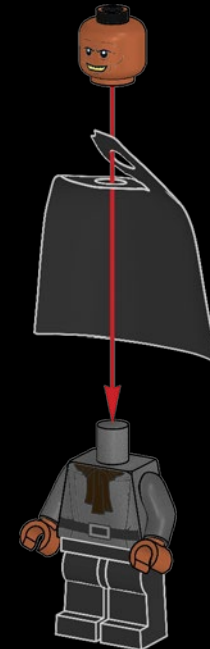

3



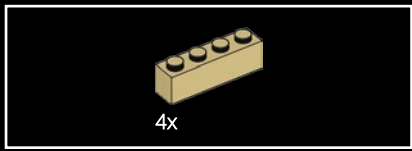

292

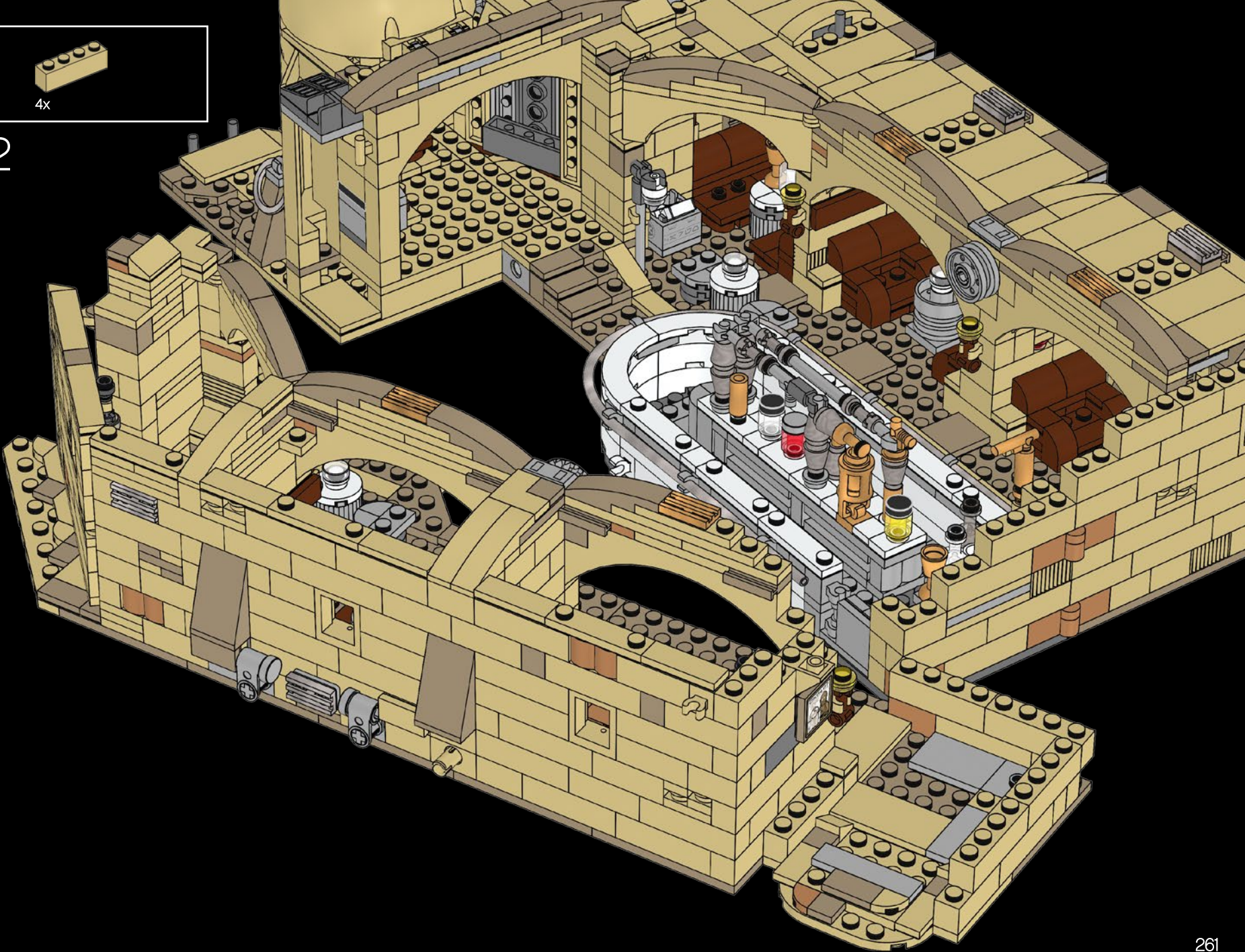

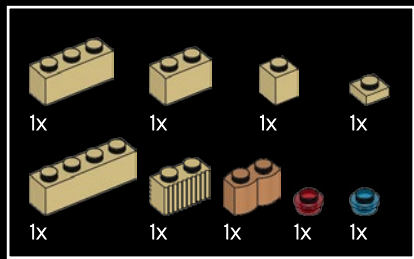

293

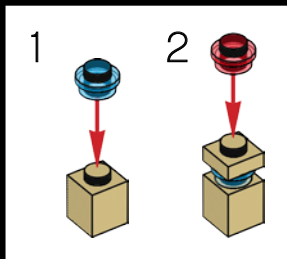
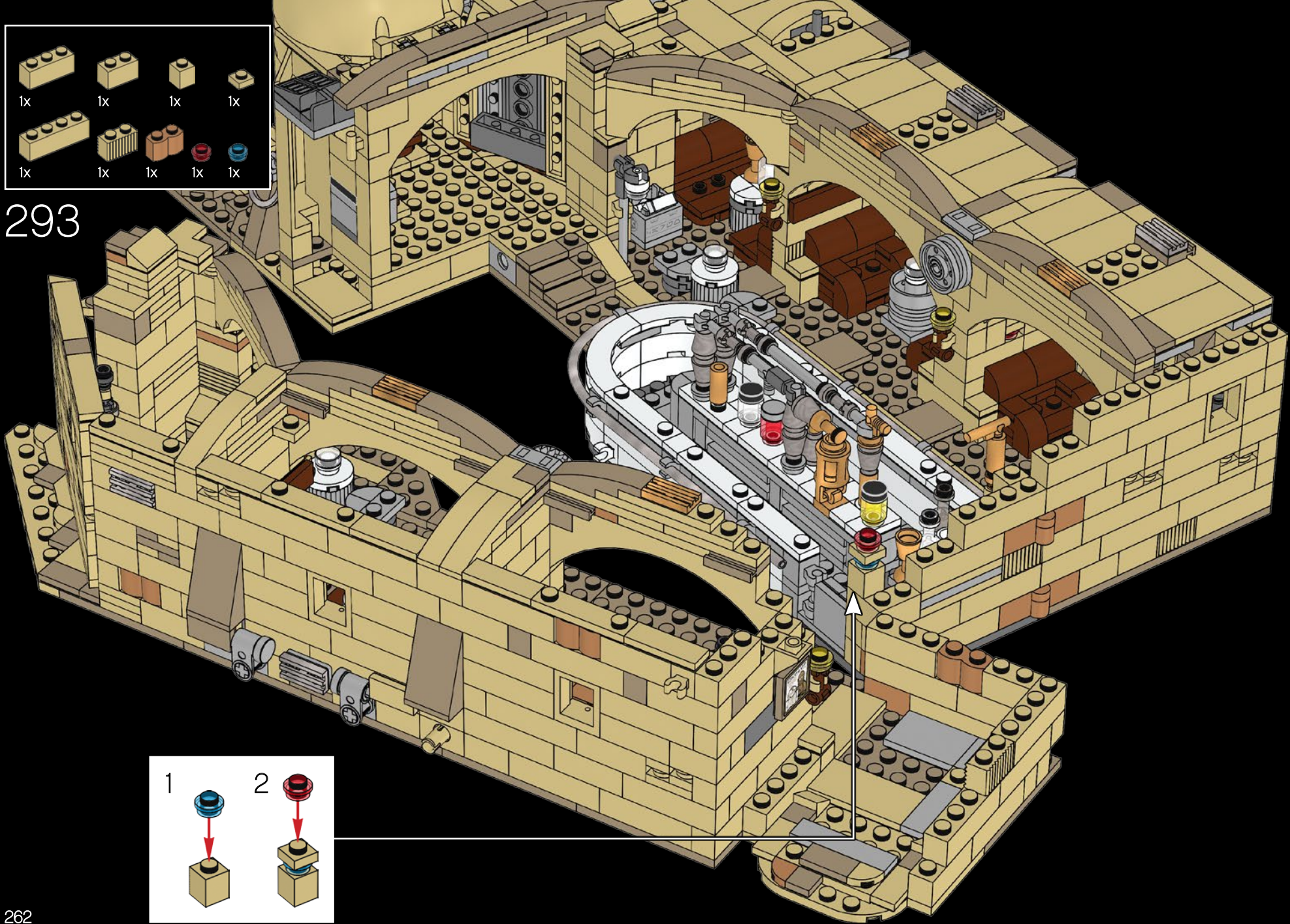

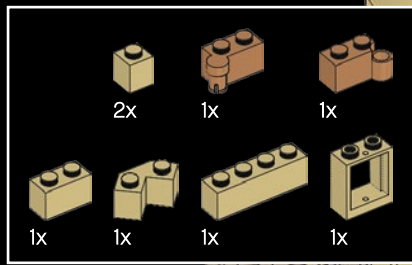

294

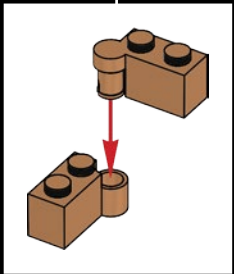
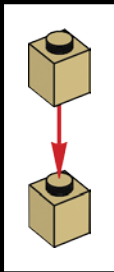
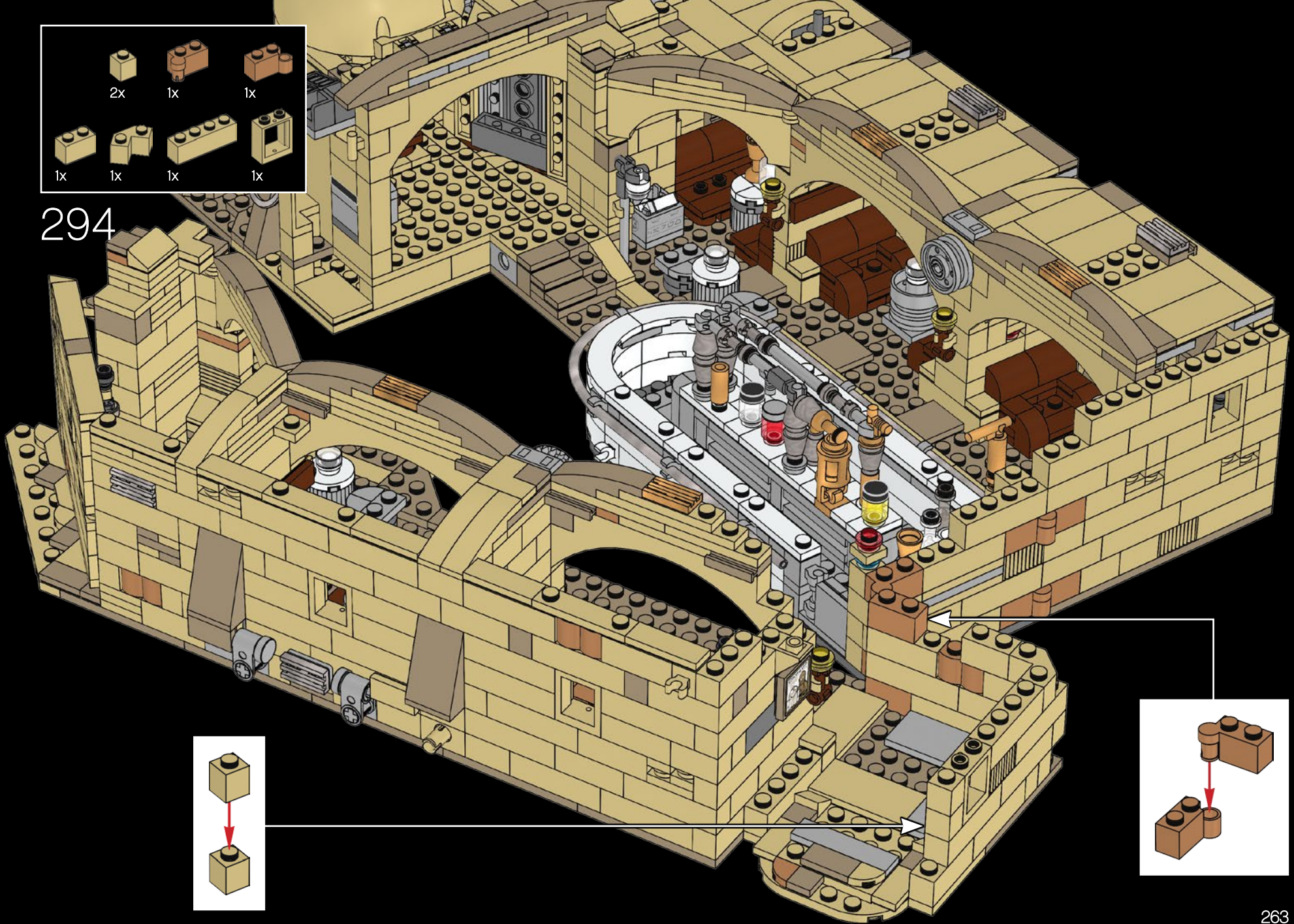

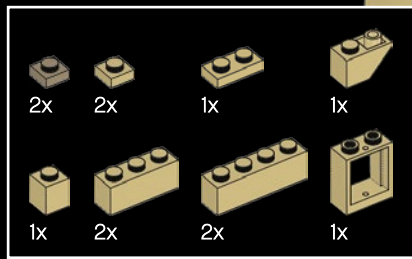

295

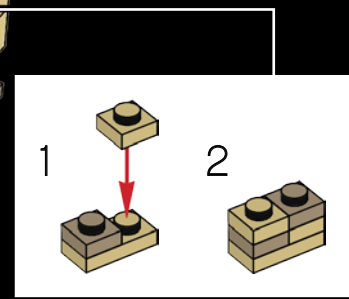
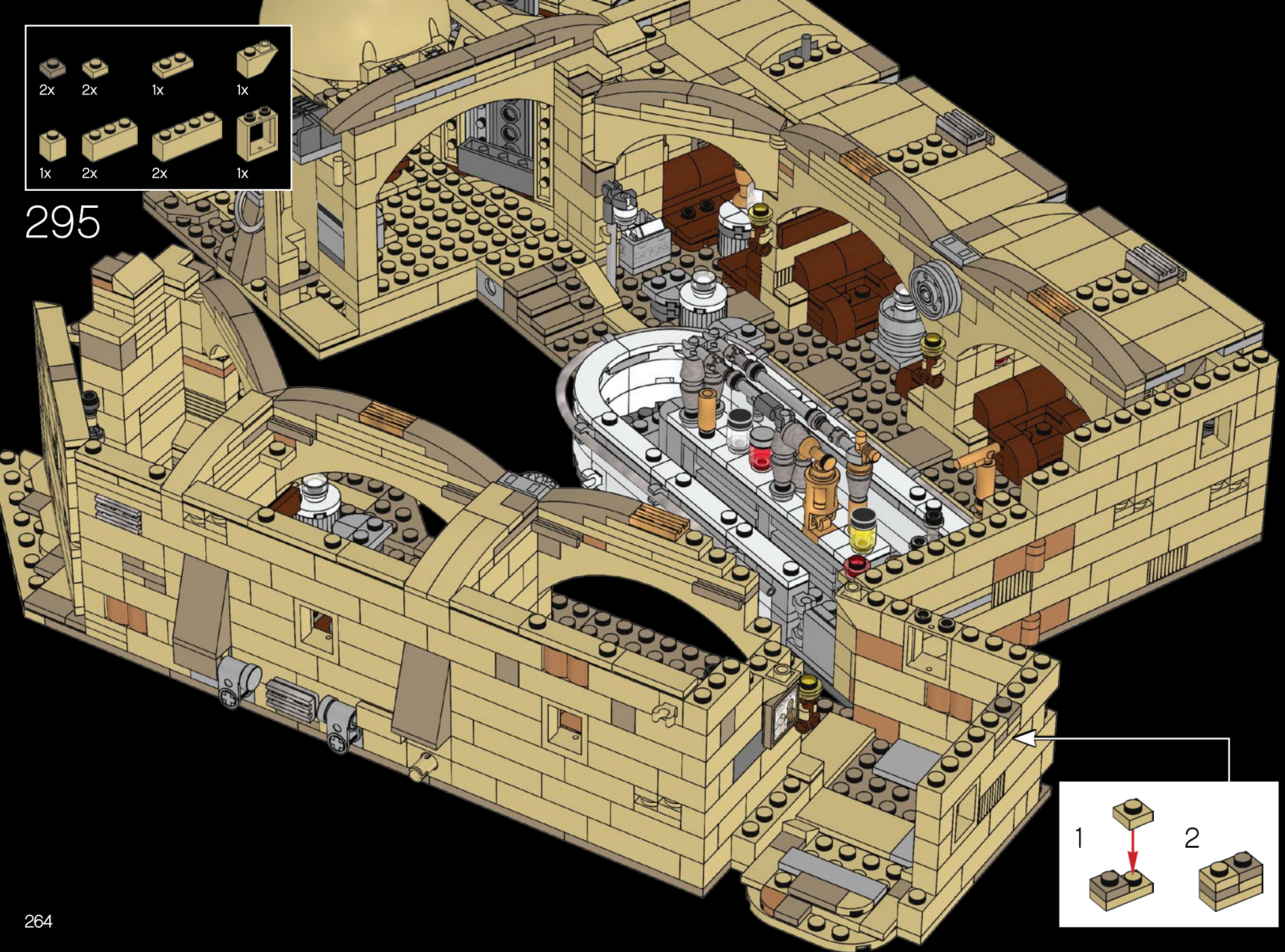

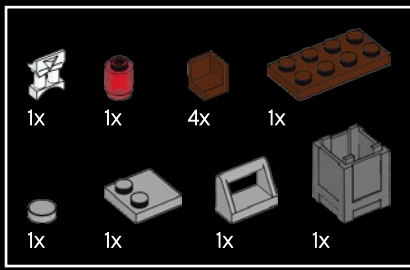

296

1

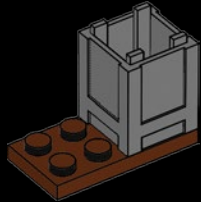

2

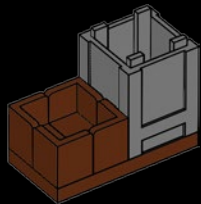

3

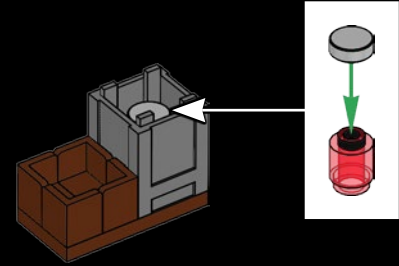

4

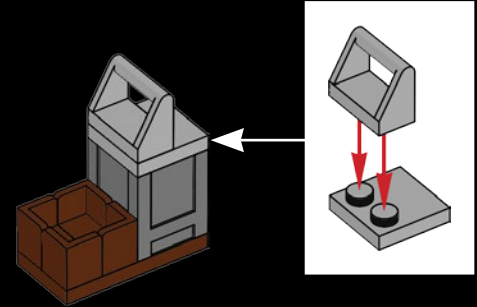

5

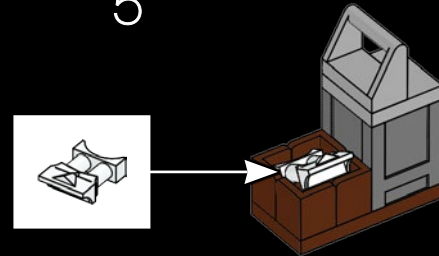

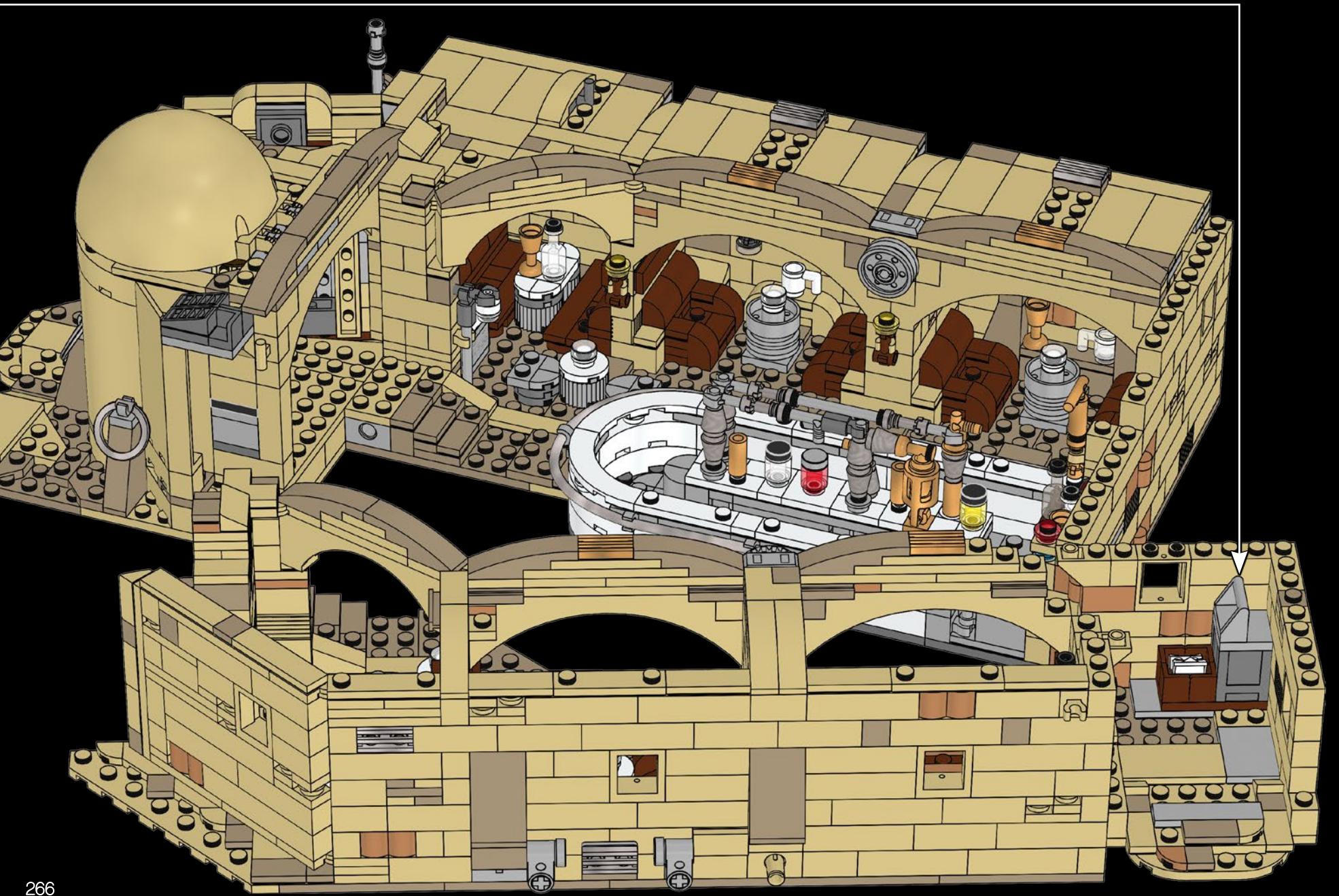

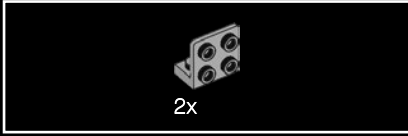

2x

297

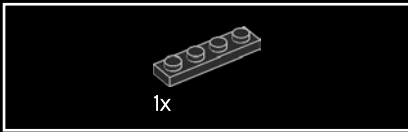
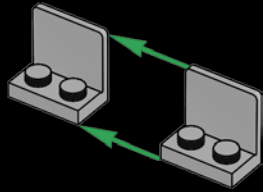

1x

298

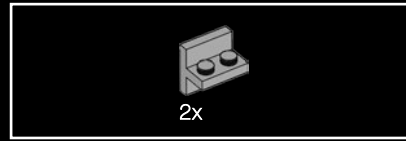
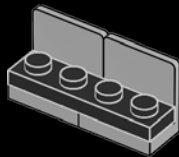

2x

299

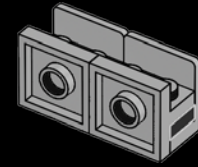

1x

1x

300

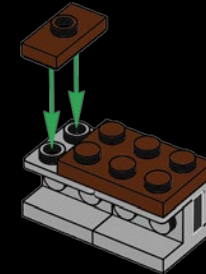

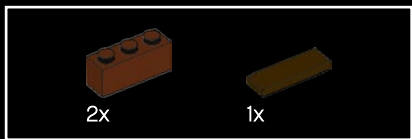

301

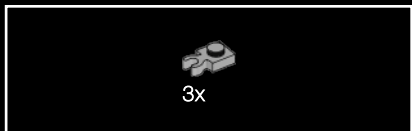
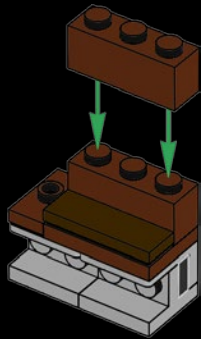

302

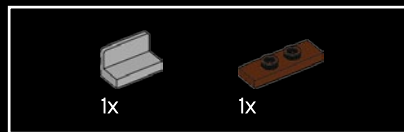
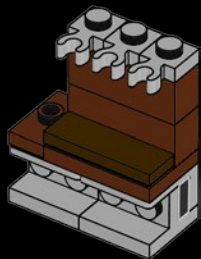

303

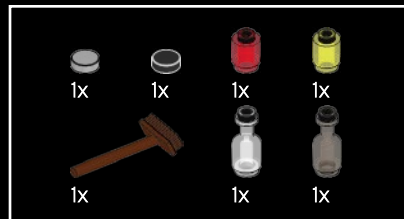
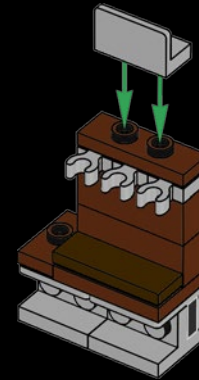

304

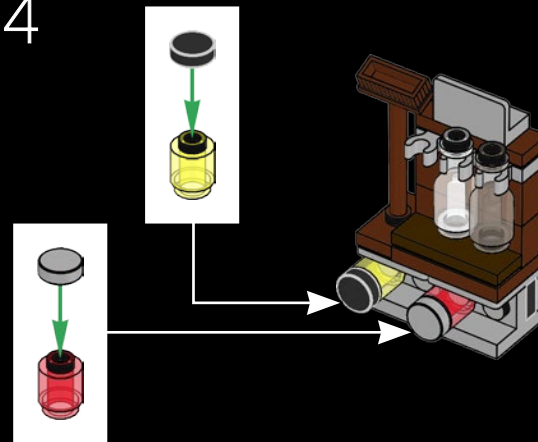

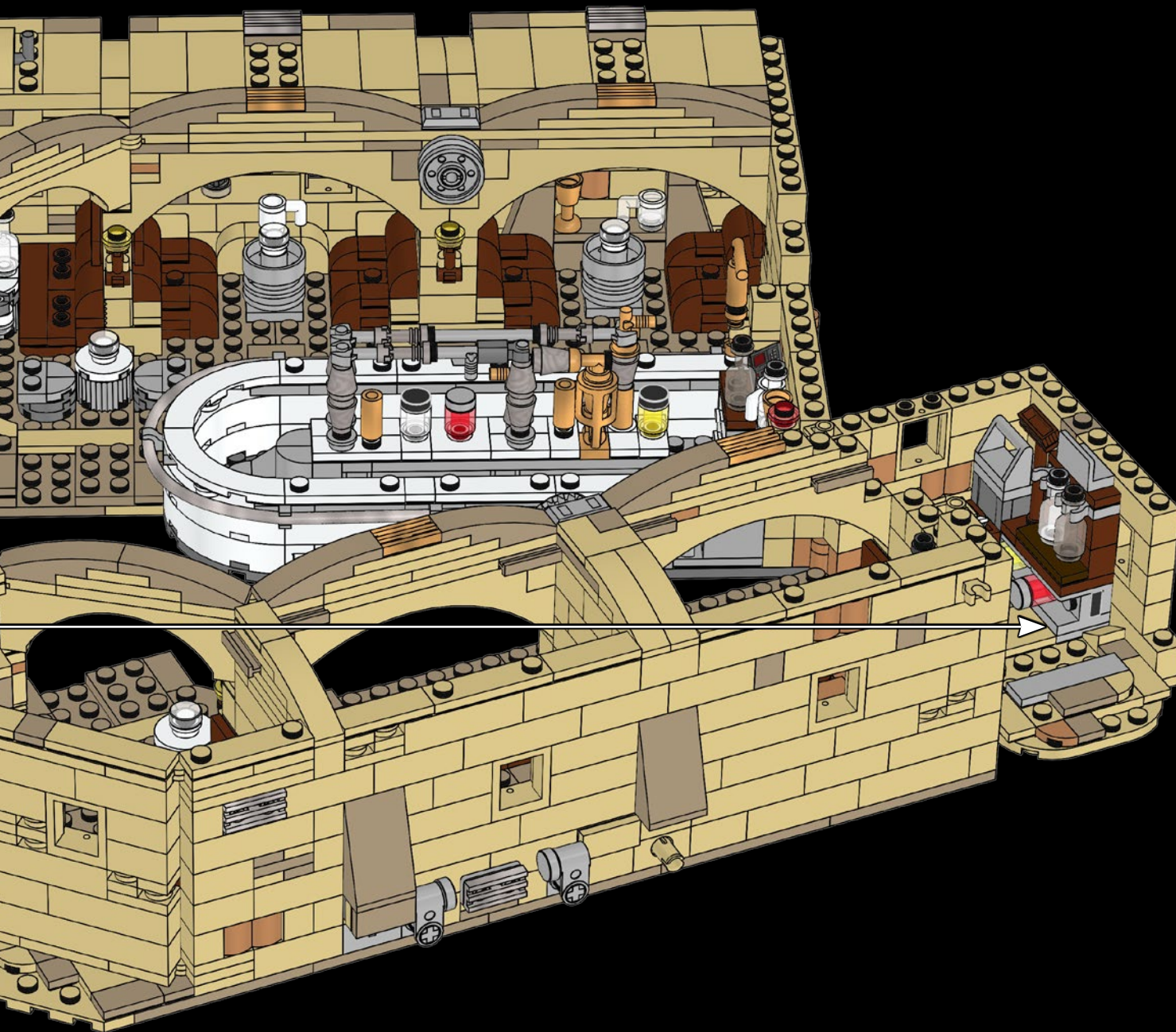







The back of the Cantina is never seen in any of the *Star Wars*™ films, concept art, animated series or graphic novels. The LEGO® designers were granted creative liberties to complete the model. The storage room where Wuher keeps cleaning supplies and extra bottles is an exclusive feature for this set.

On ne voit jamais l'arrière de la cantina, que ce soit dans les films, les croquis conceptuels, les séries animées ou les romans graphiques de *Star Wars*™. Les concepteurs LEGO® ont été autorisés à exercer leur liberté créative afin de compléter le modèle. L'espace de rangement, où Wuher entrepouse des produits de nettoyage et des bouteilles additionnelles, est une caractéristique exclusive de cet ensemble.

La parte posterior de la cantina no aparece en ninguna de las películas, obras de arte conceptual, series de animación ni novelas gráficas de la saga *Star Wars*™. Los diseñadores de LEGO® recibieron libertad creativa para completar el modelo. El almacén donde Wuher guarda los productos de limpieza y sus provisiones de bebidas es una característica exclusiva de este set.

- 2x 
- 3x 
- 1x 
- 2x 
- 2x 
- 1x 

306

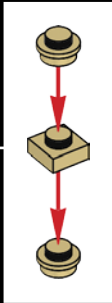
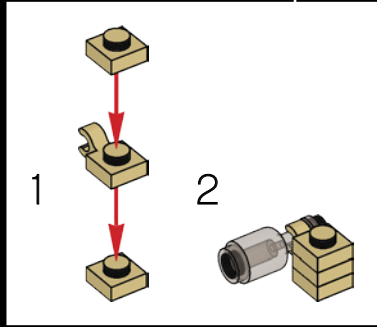
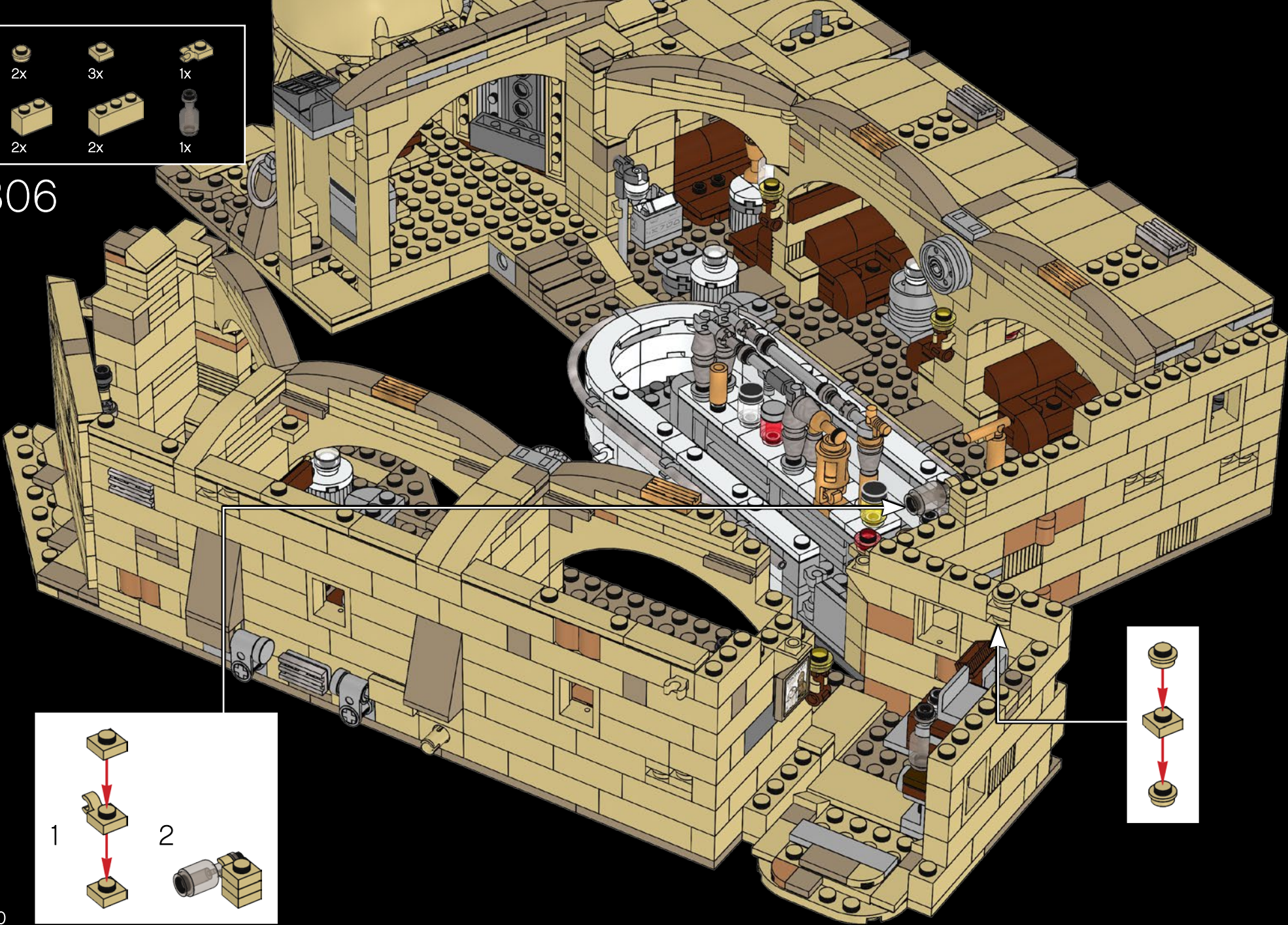

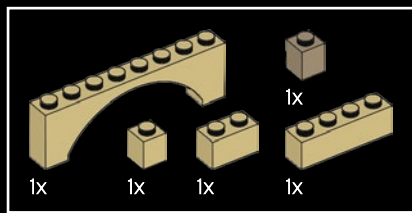

307

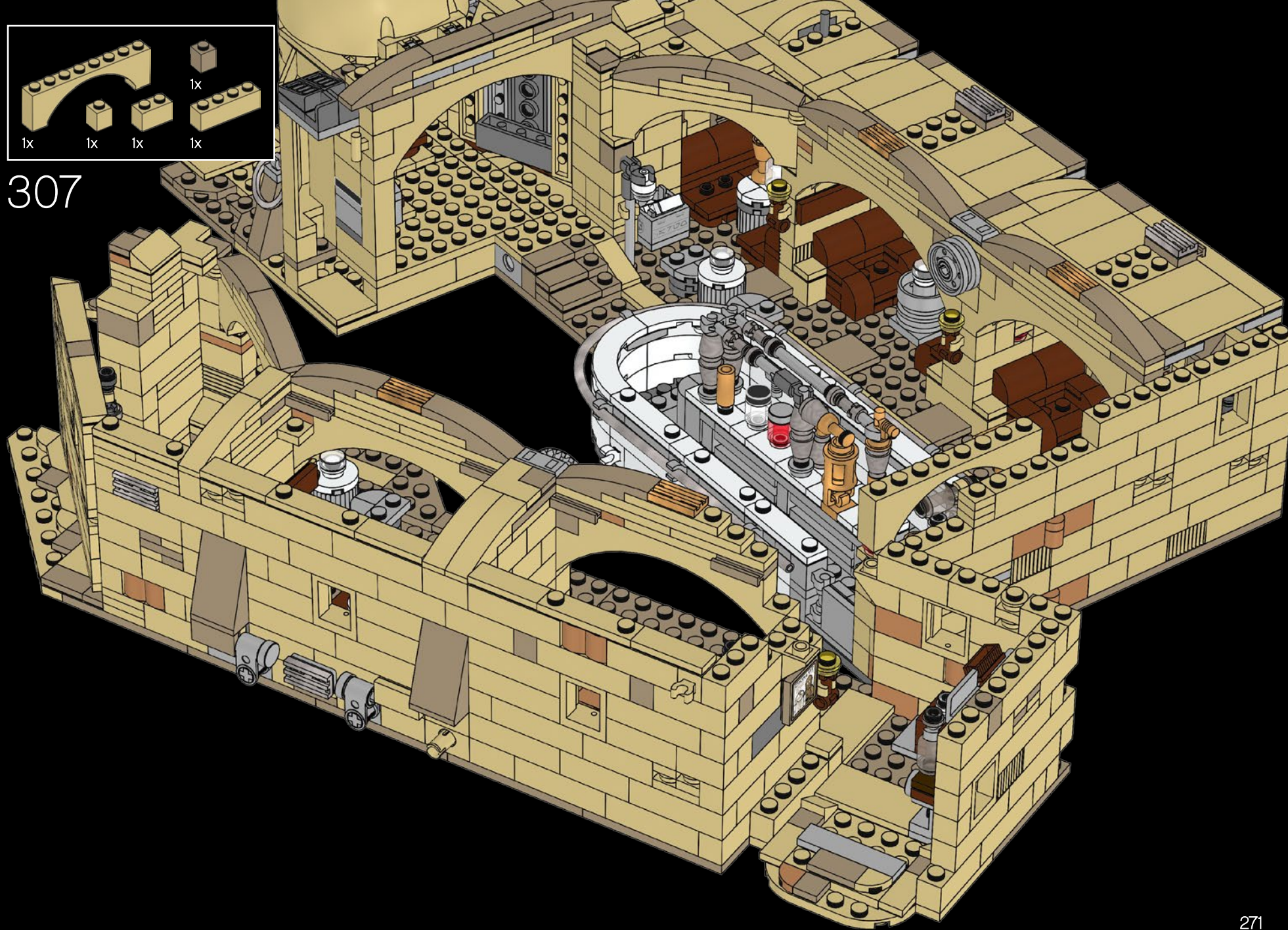

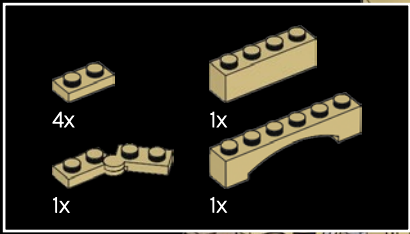

308

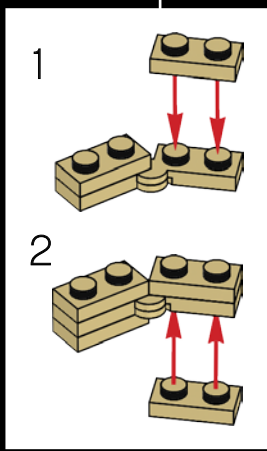
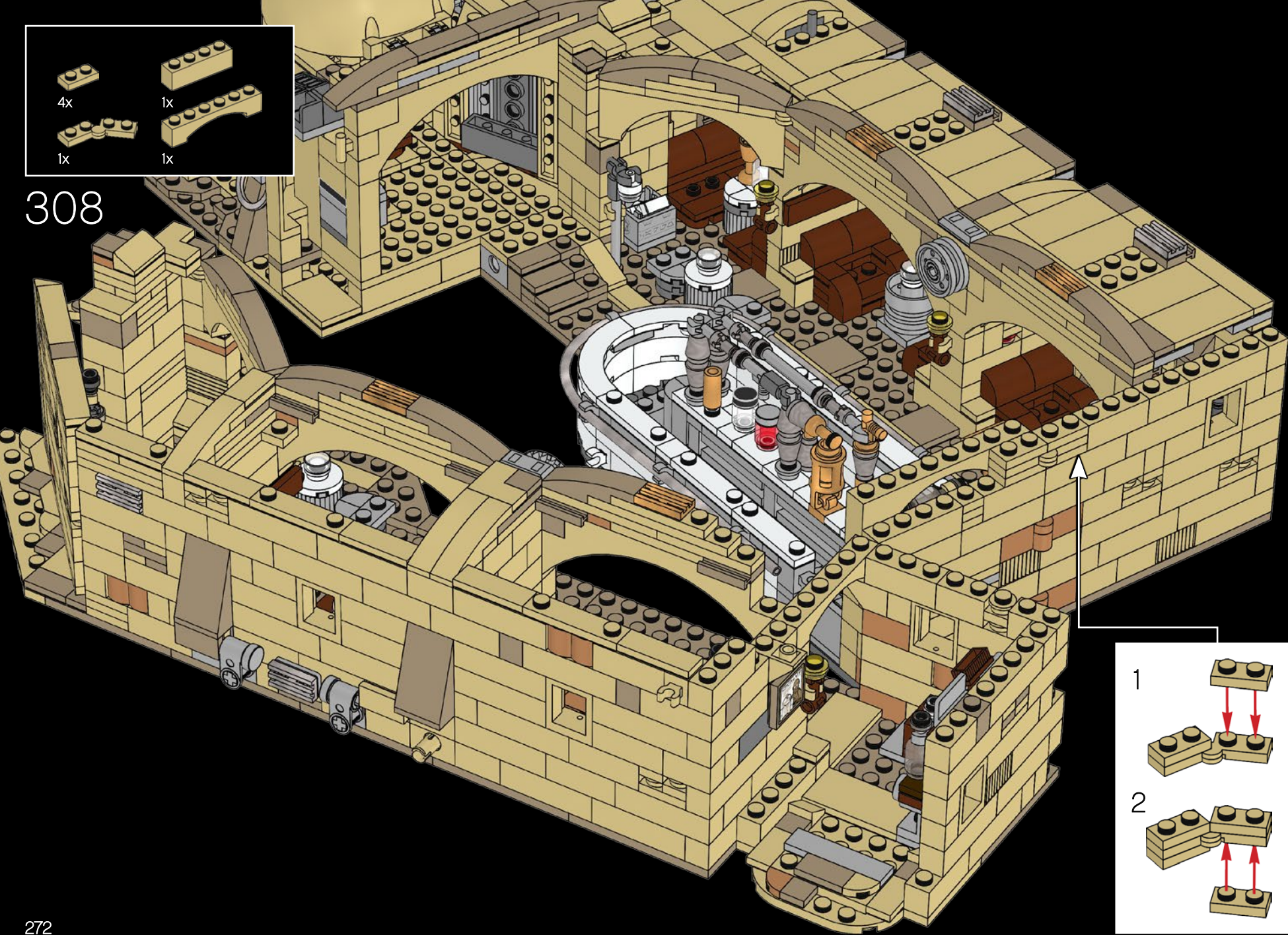

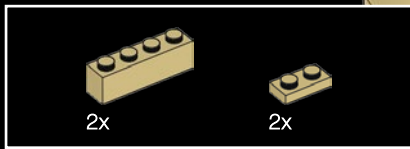

309

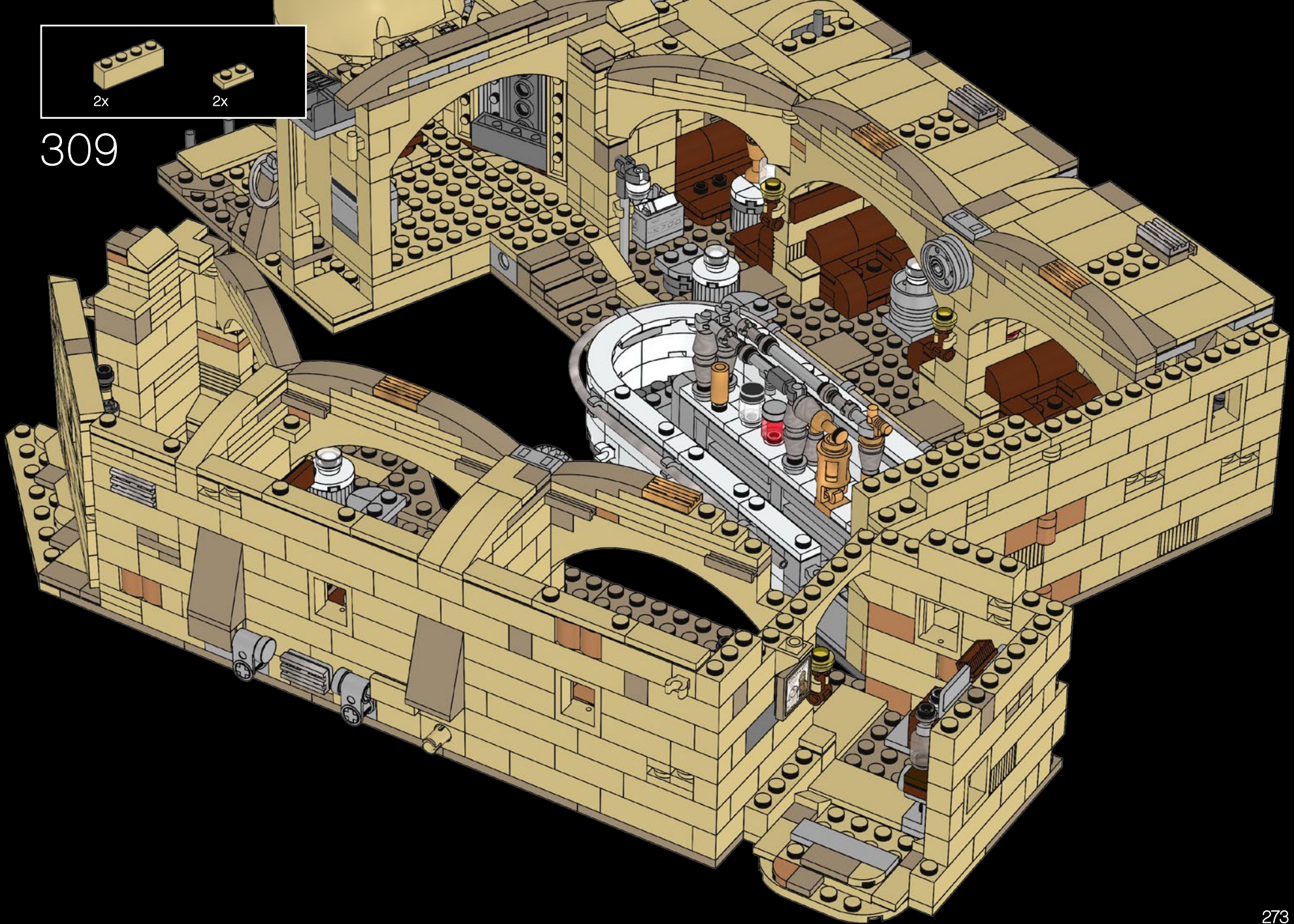



310

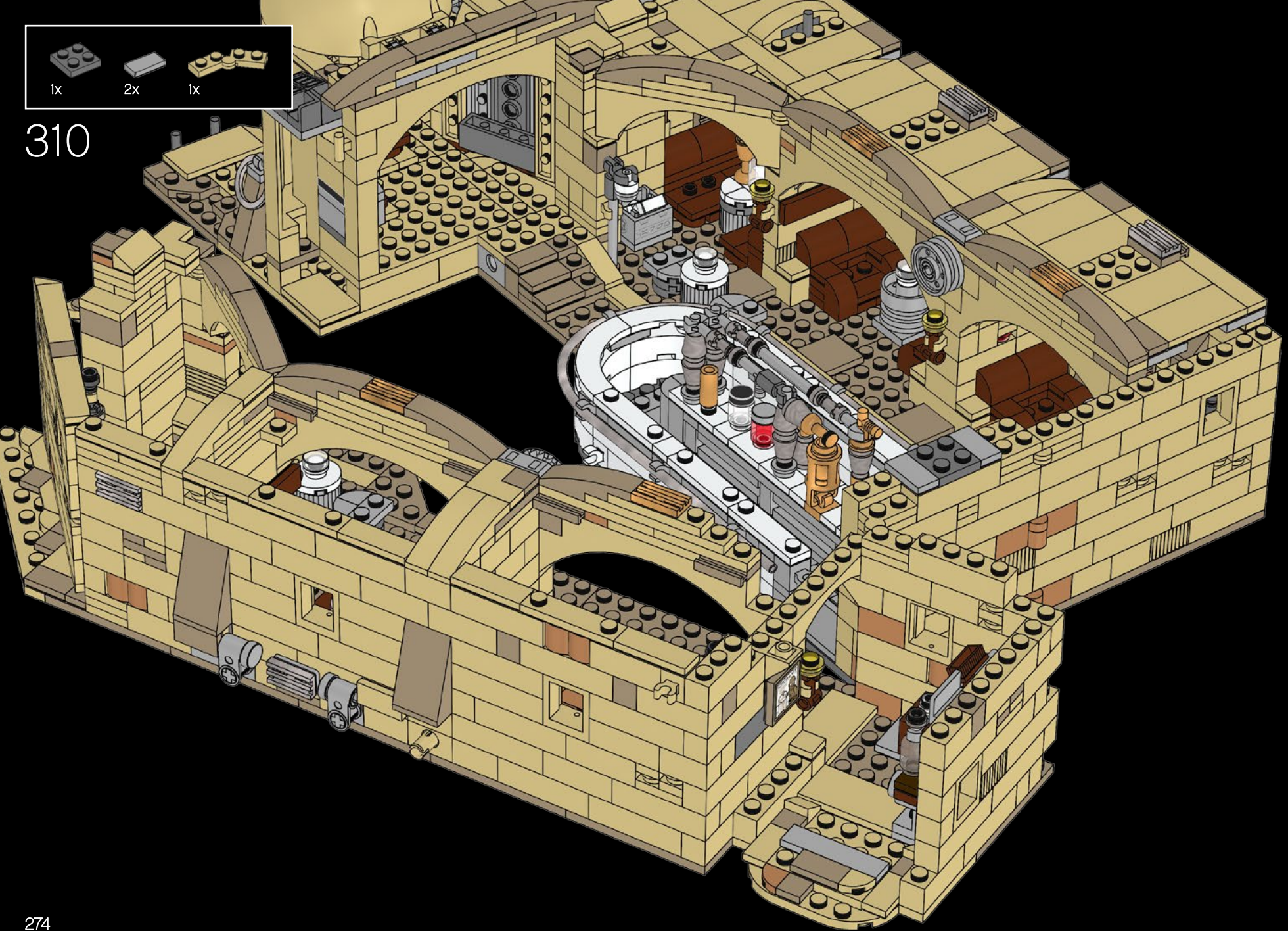

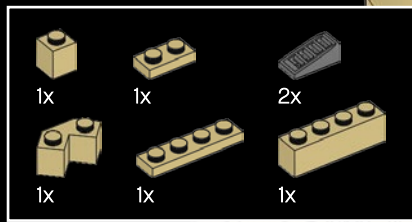

311

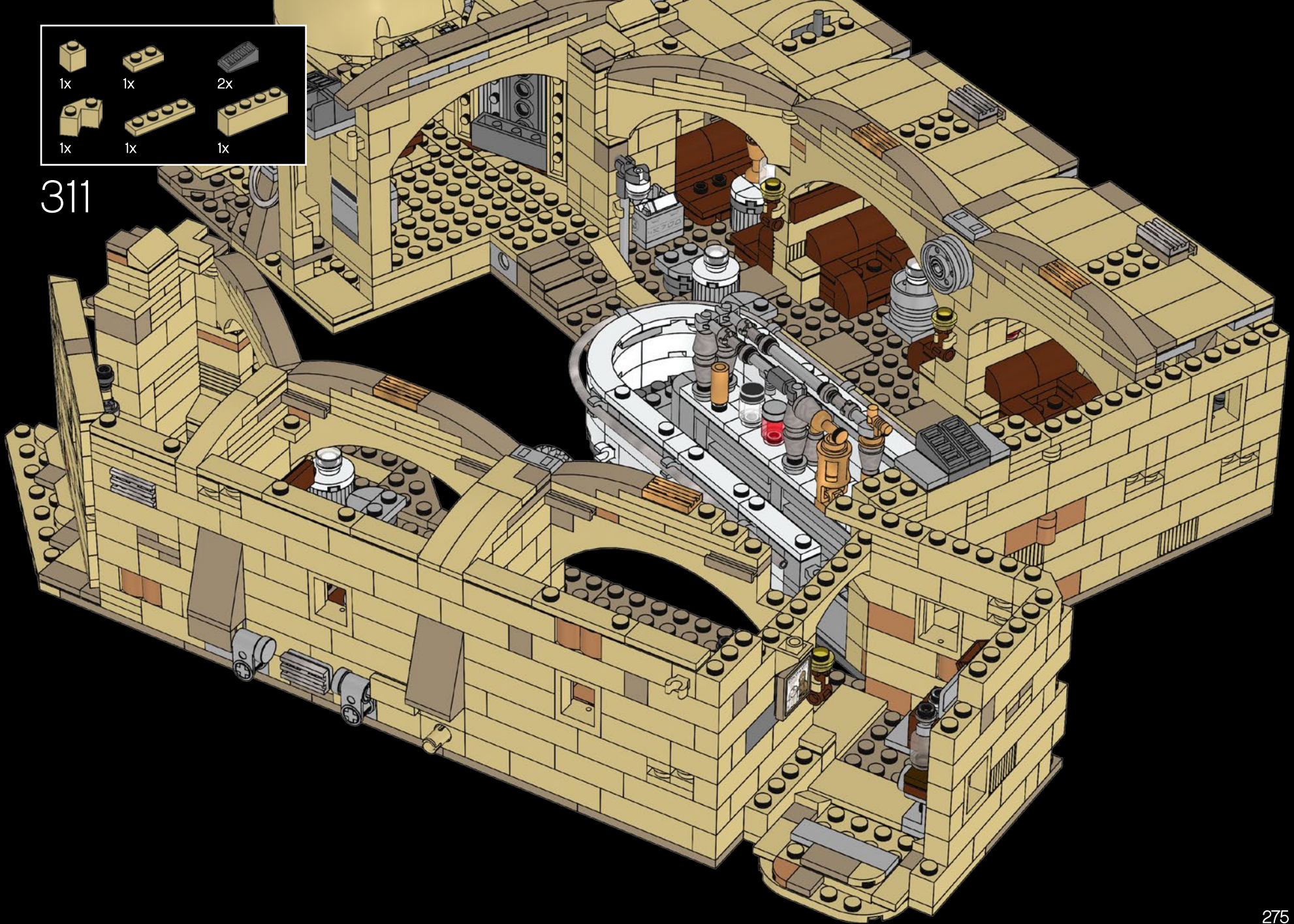

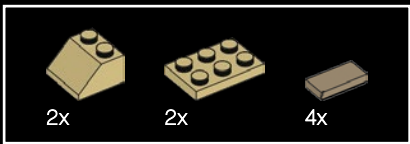

312

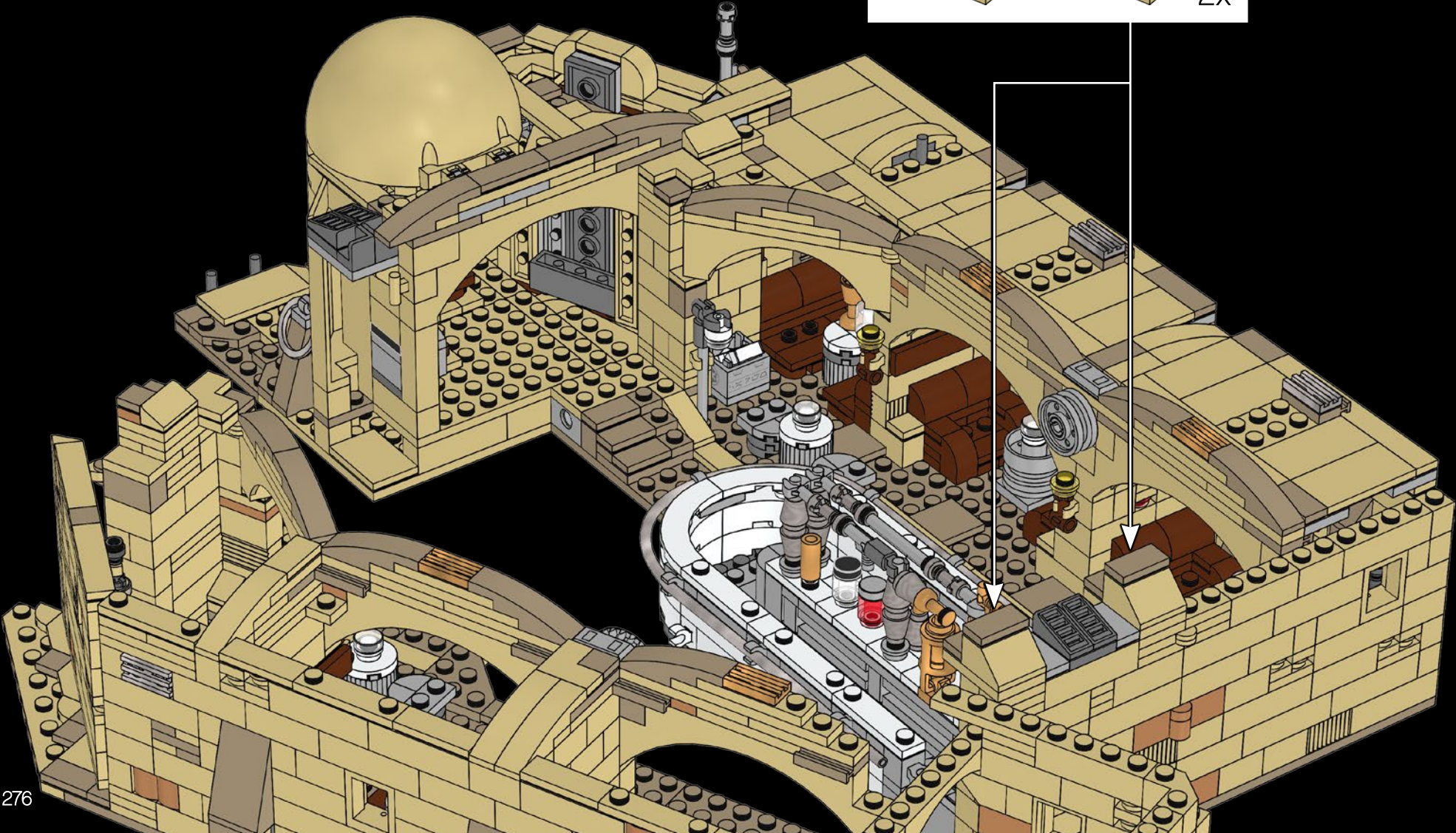
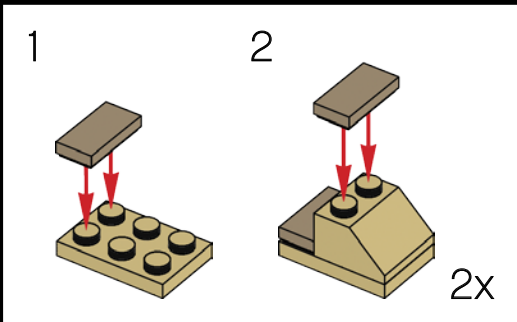

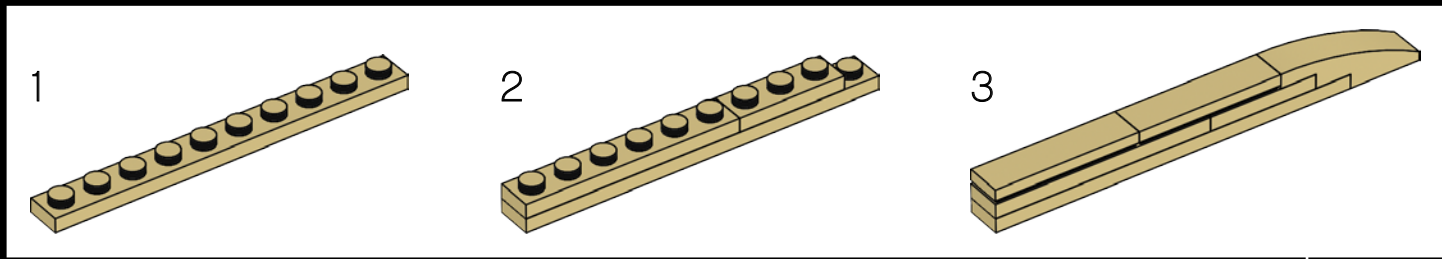
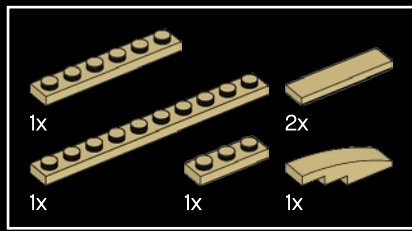

313

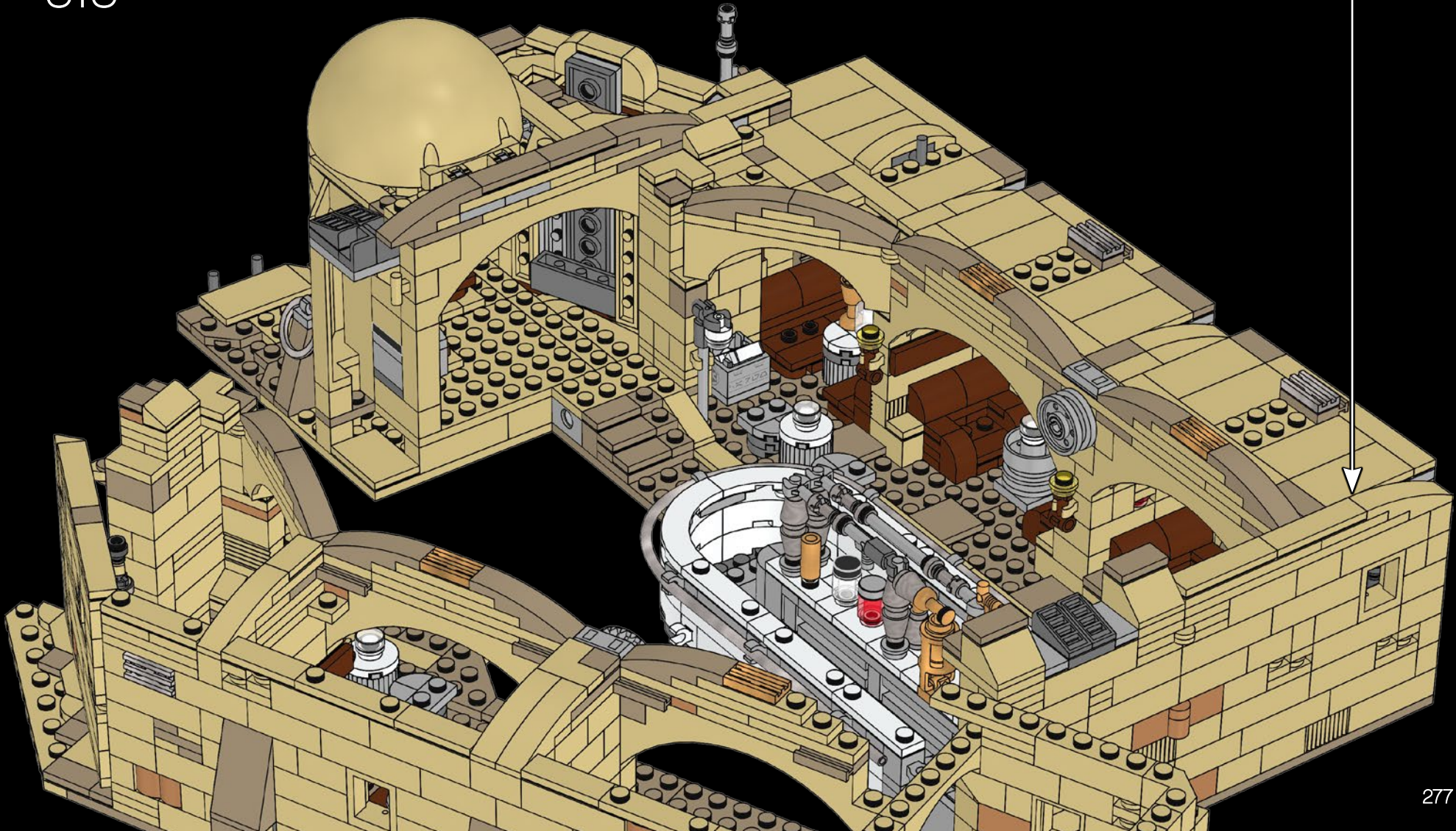

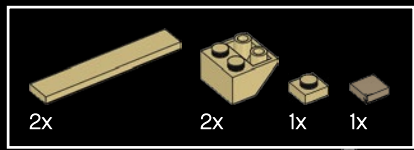

314

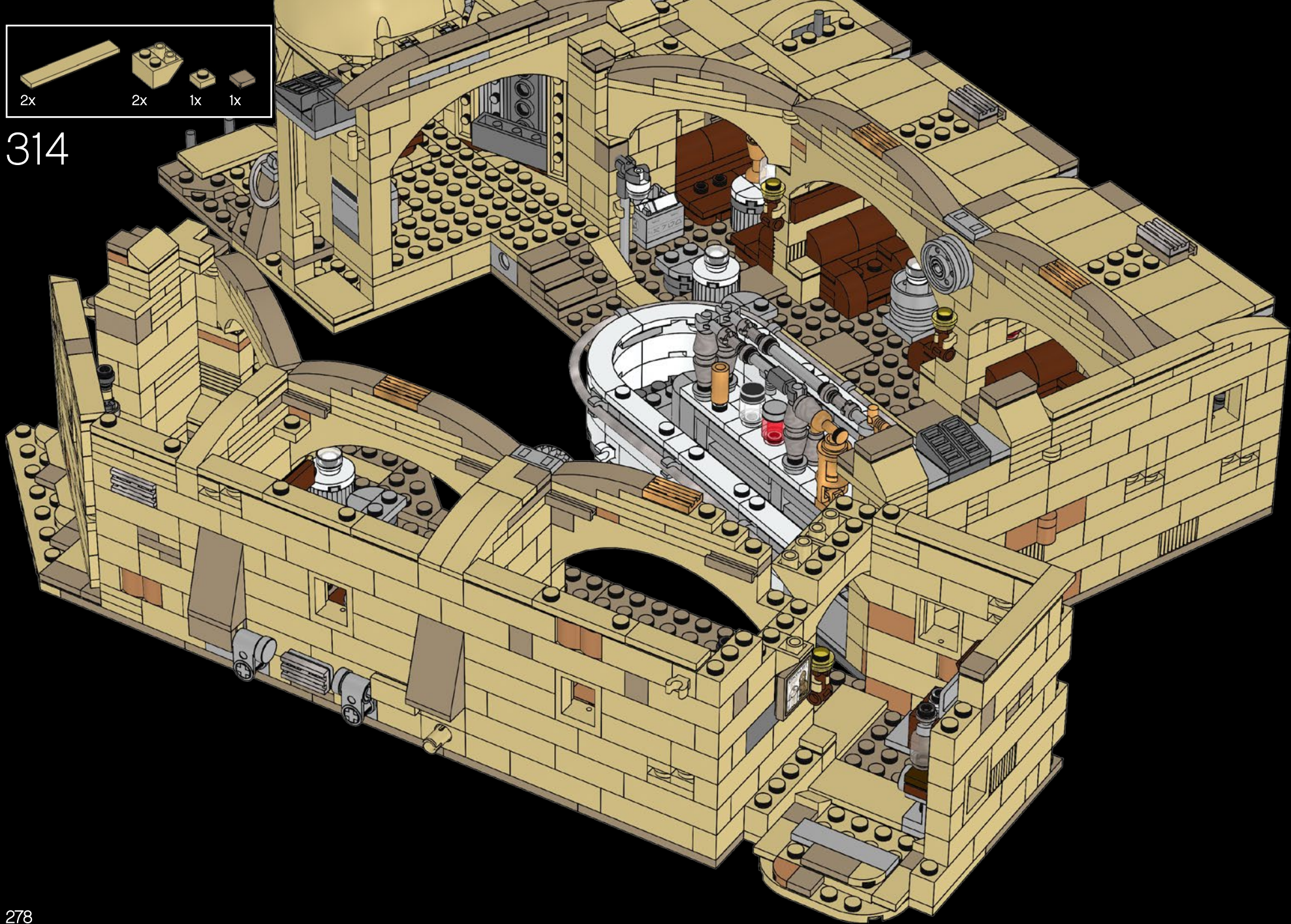

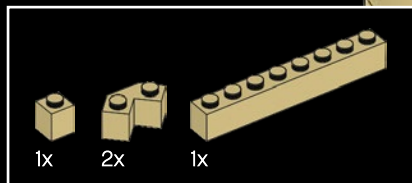

315

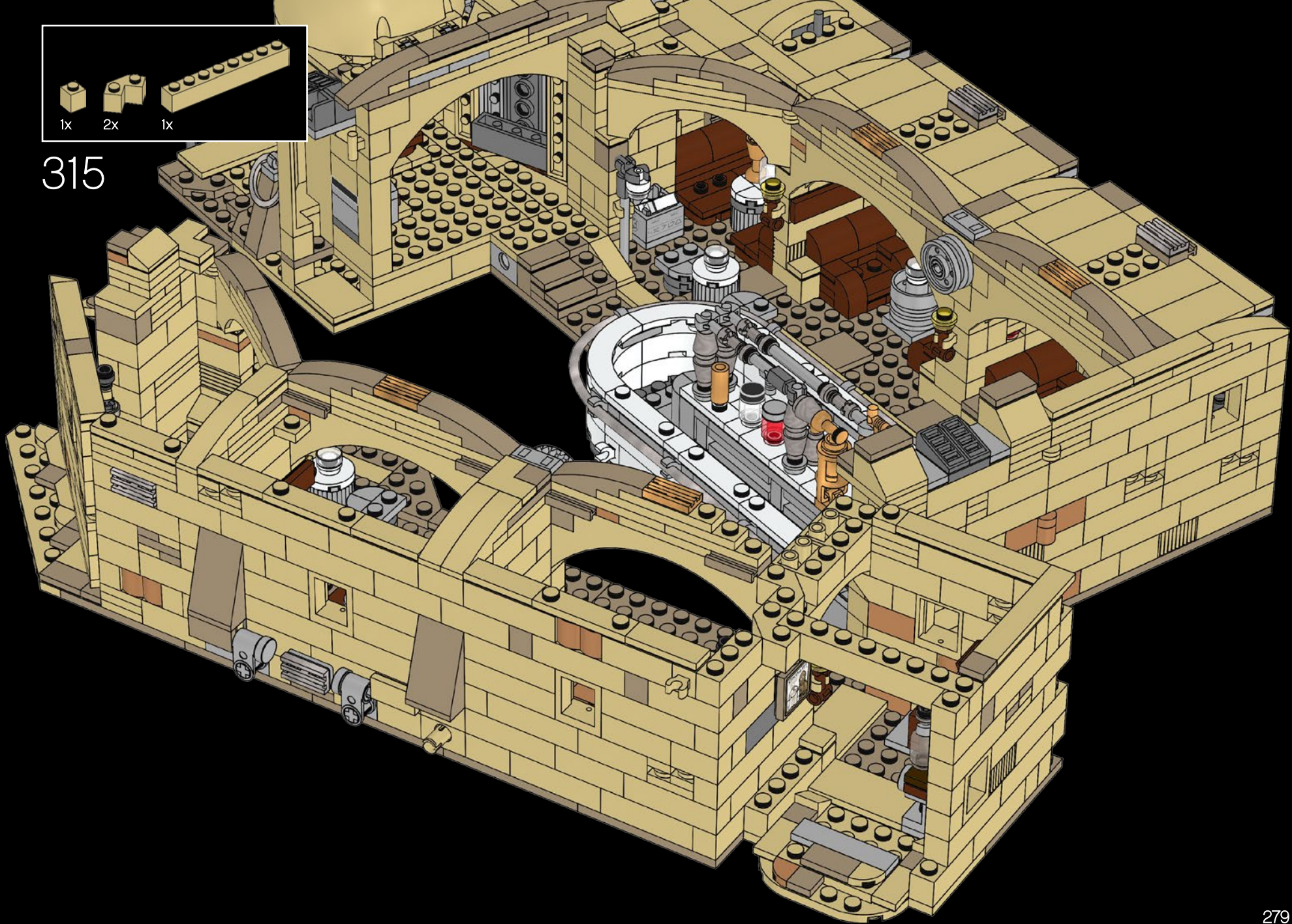

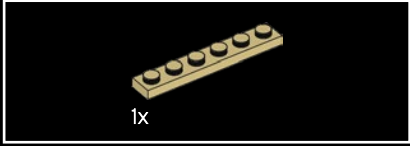
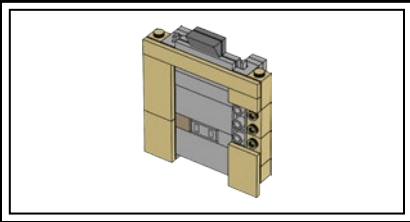

316

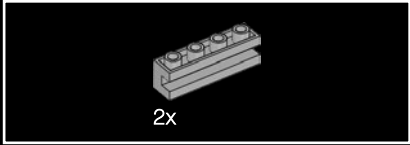

317

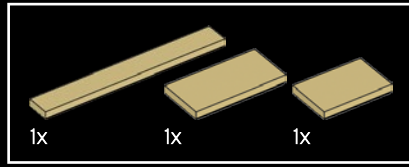
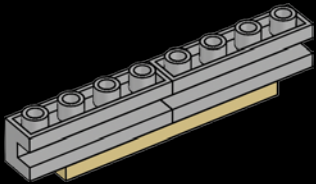

318

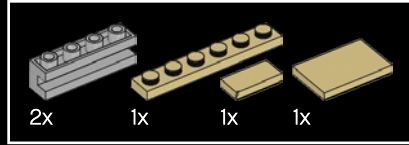
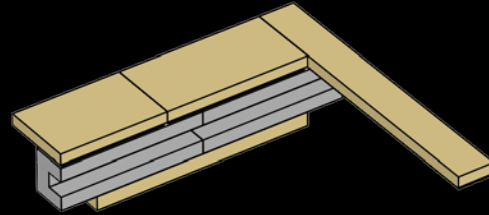

319

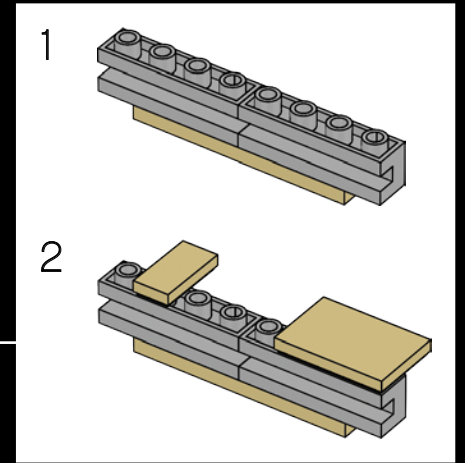
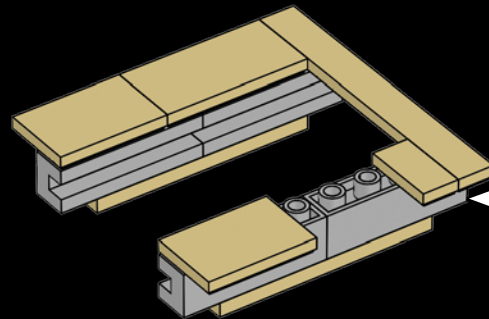



320

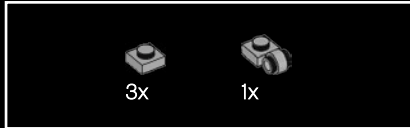
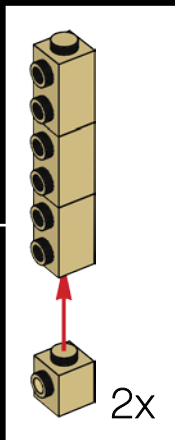
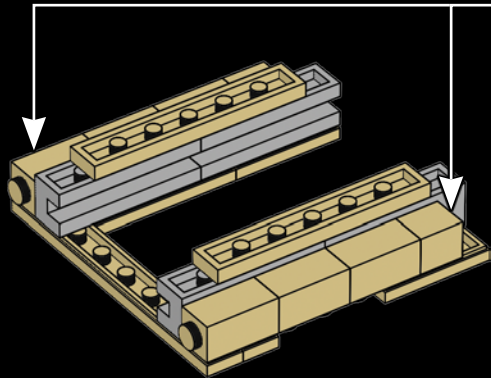

321

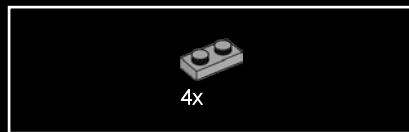
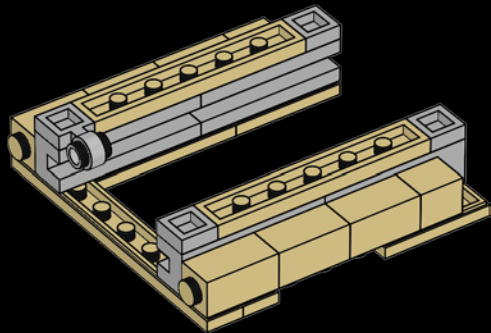

322

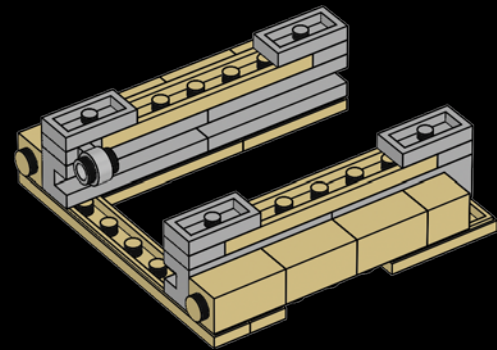

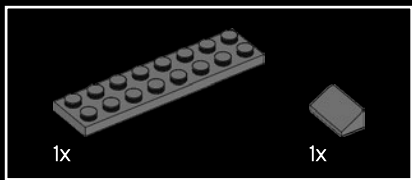

323

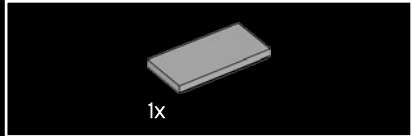
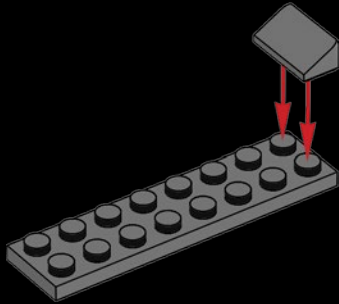

324

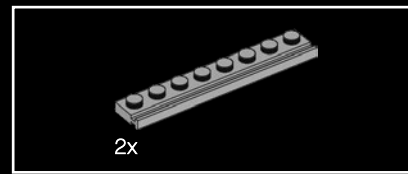
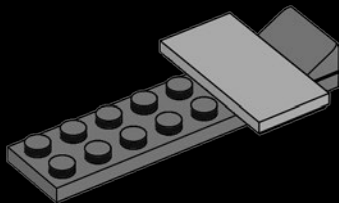

325

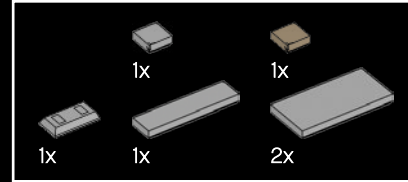
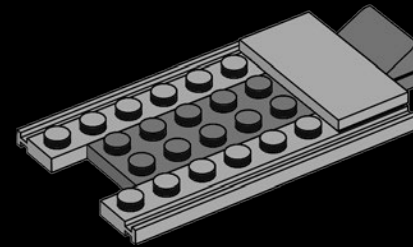

326

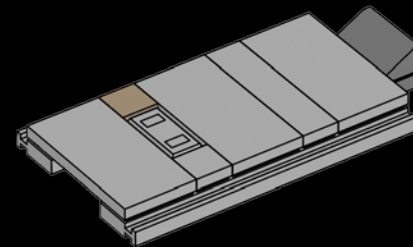



327

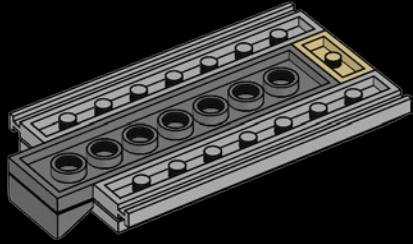

328

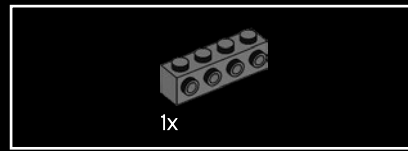
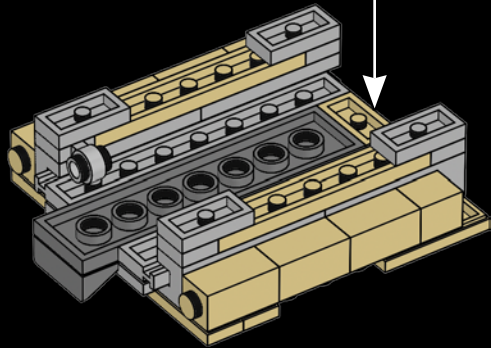

329

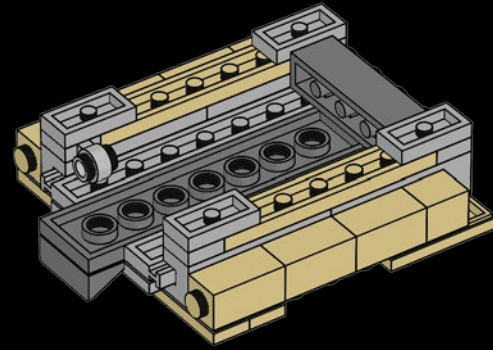

330

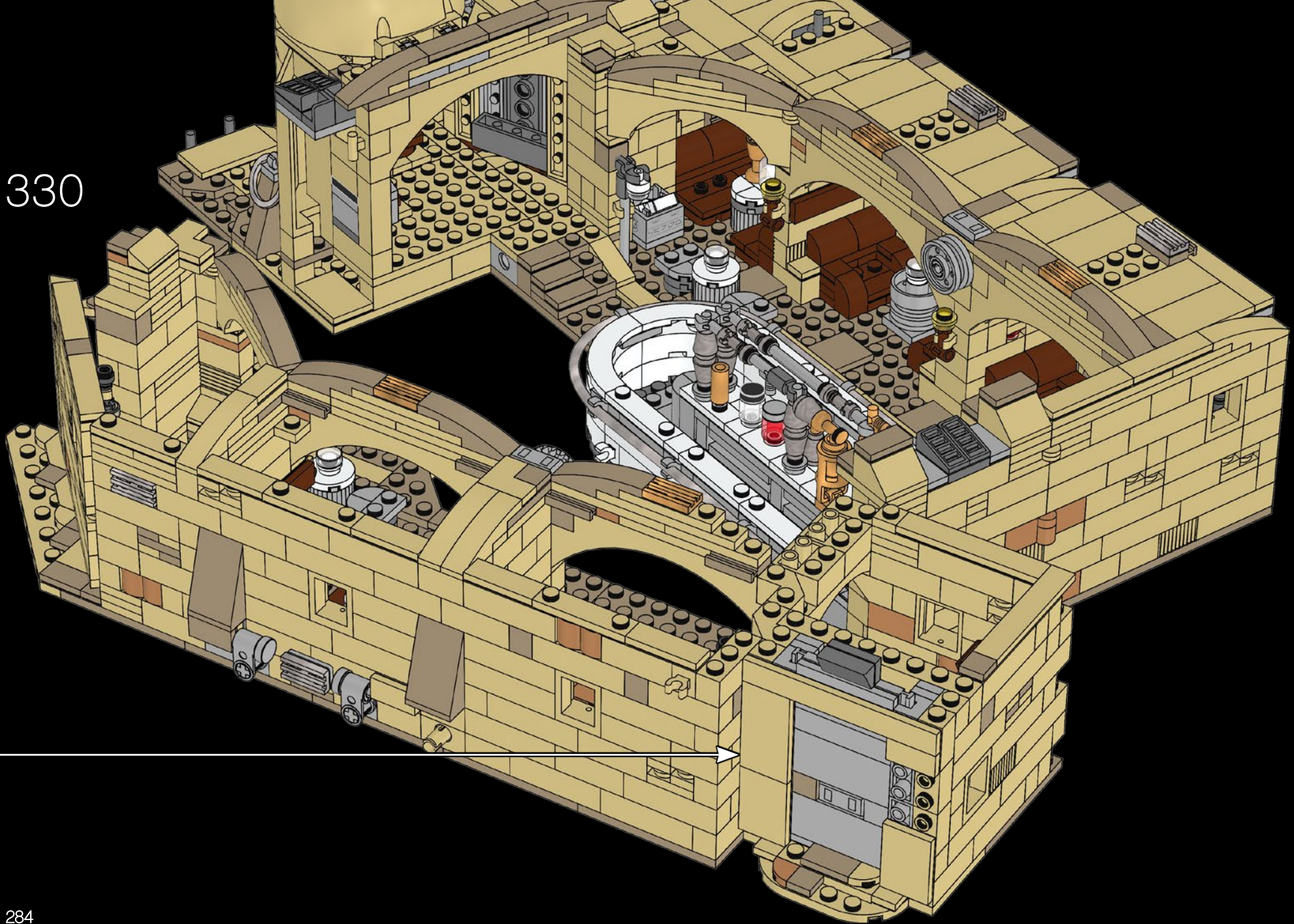

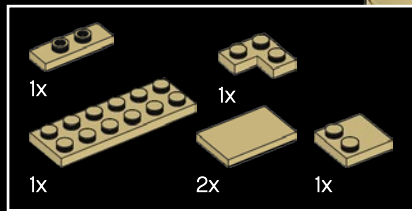

331

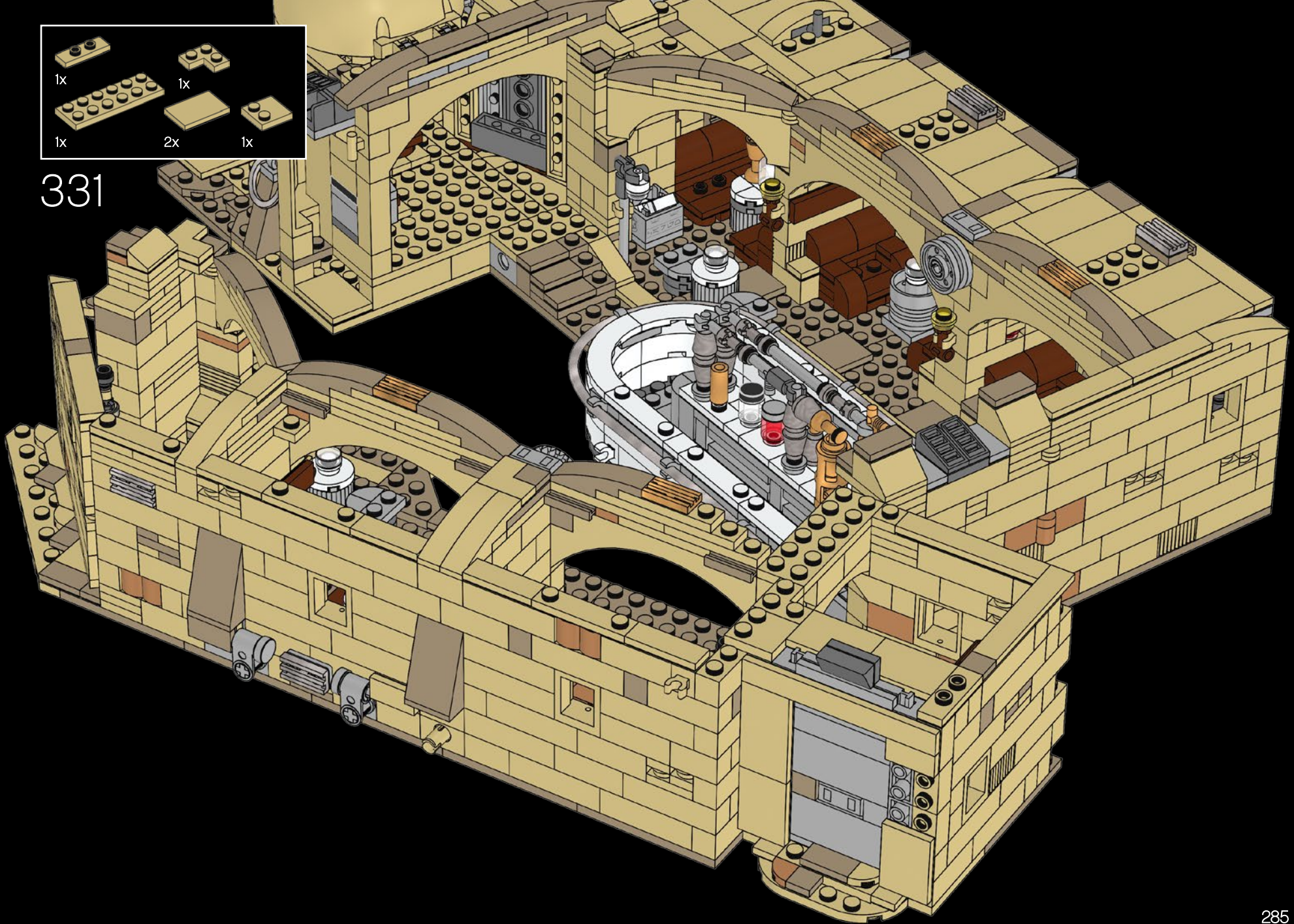

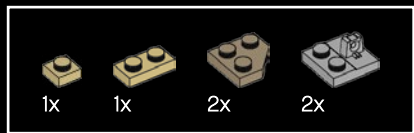

332

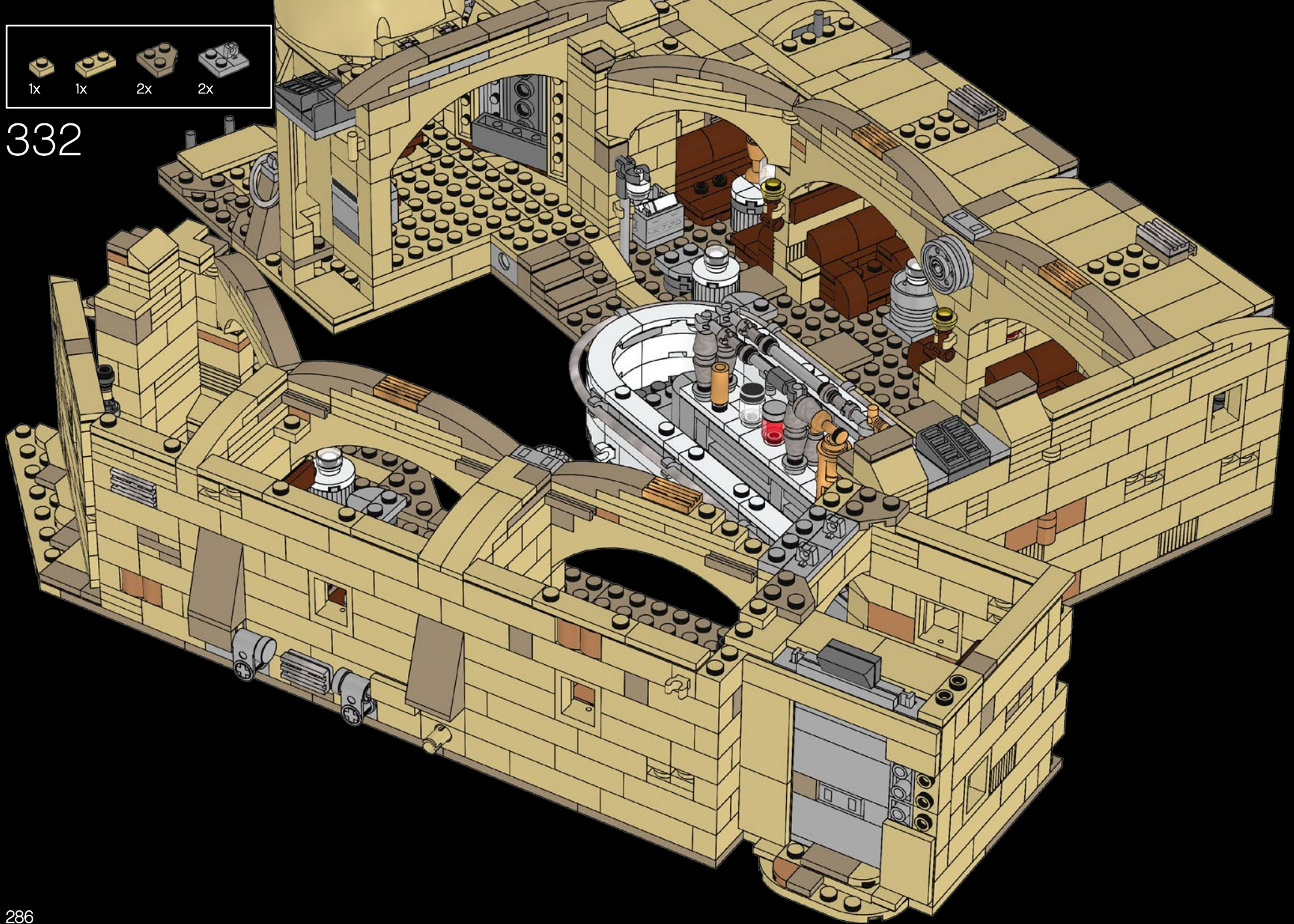

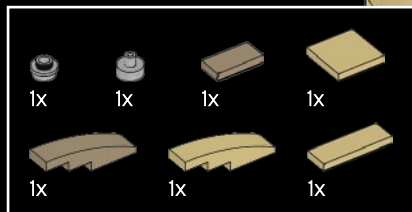

333

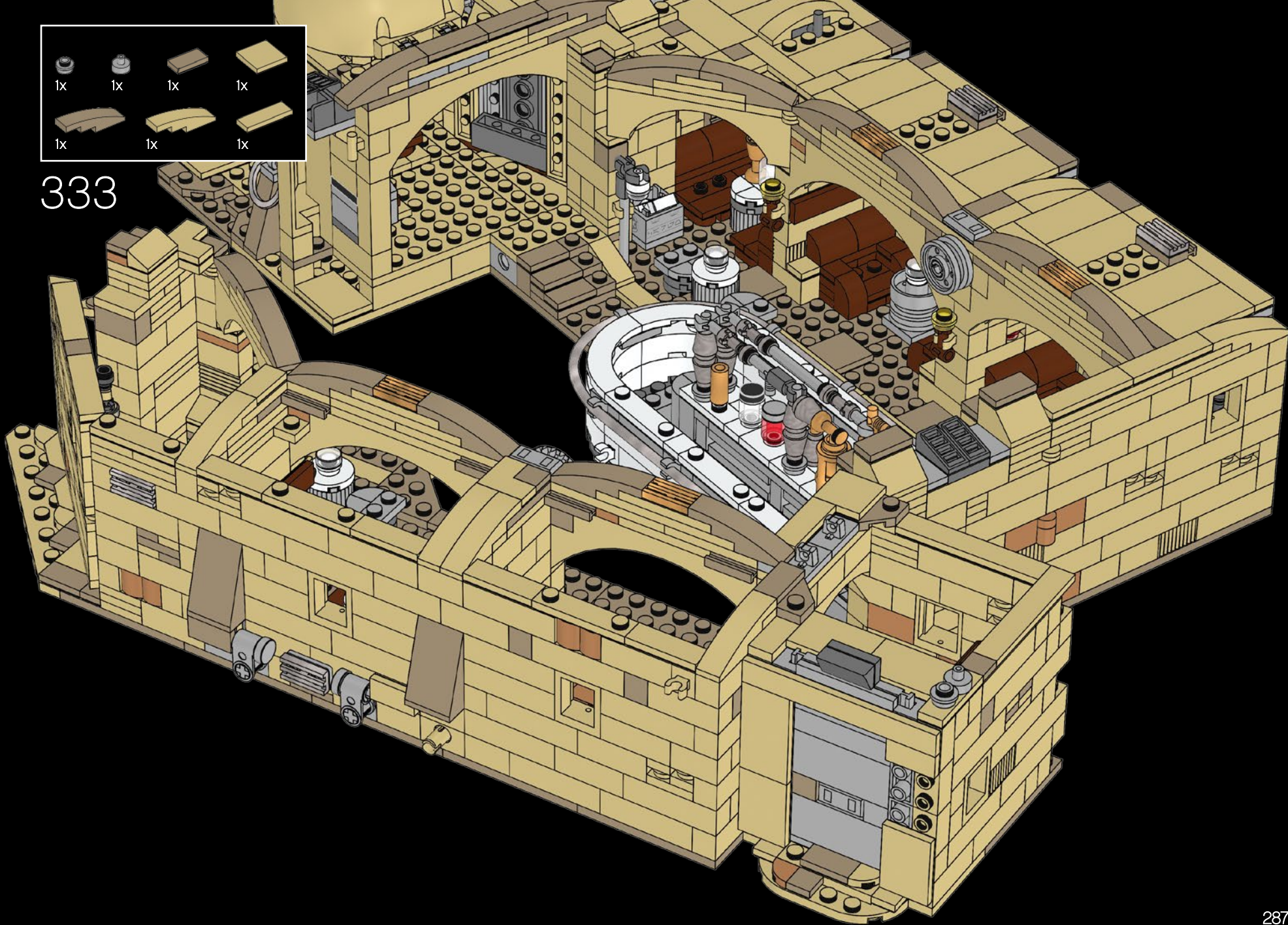

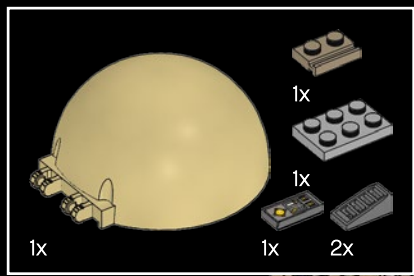

334

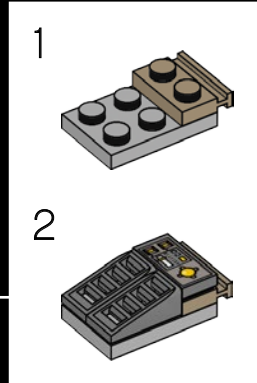
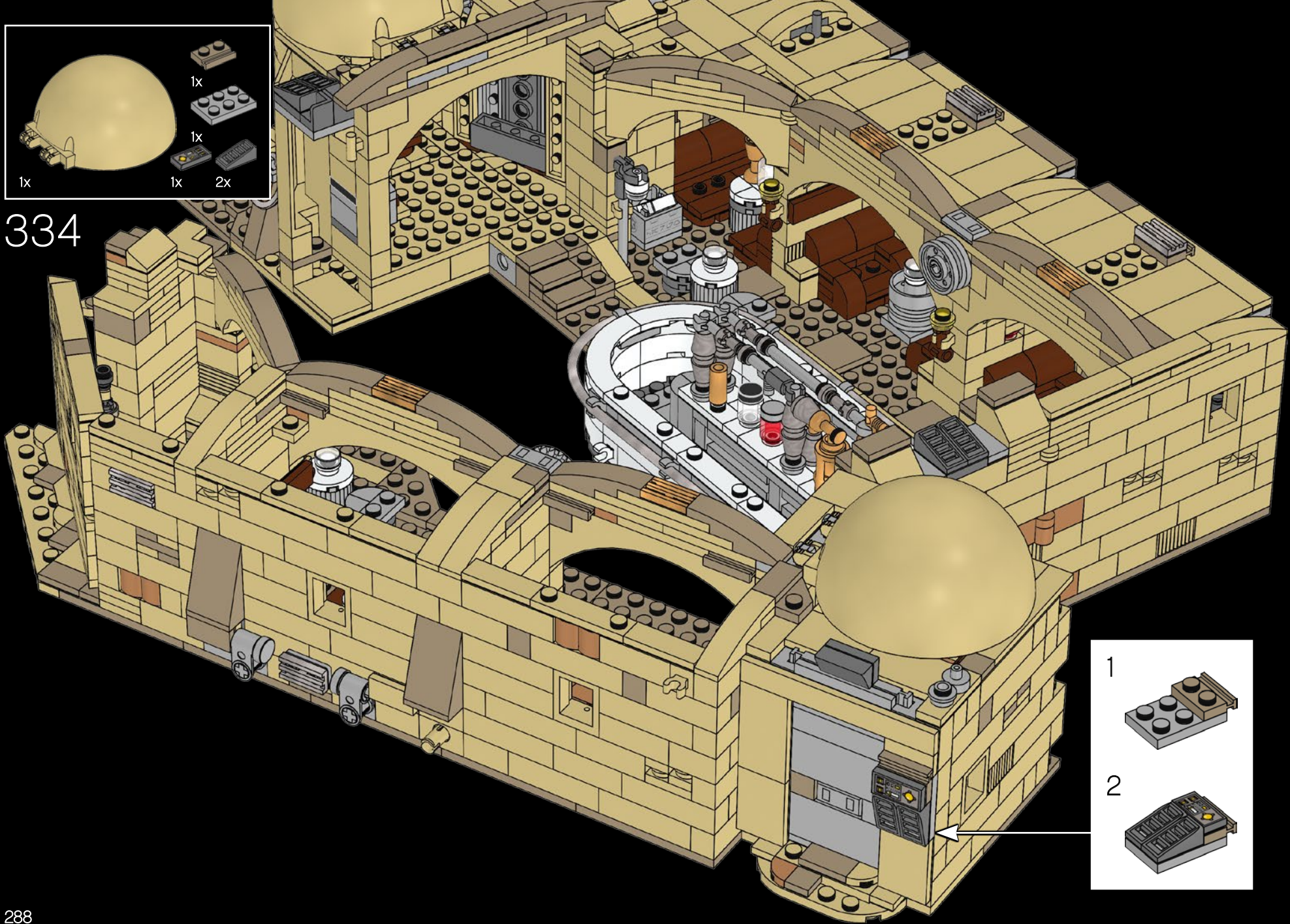

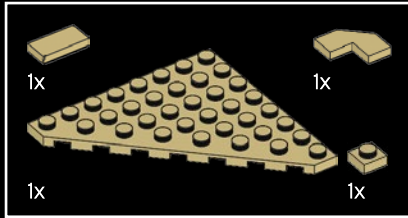
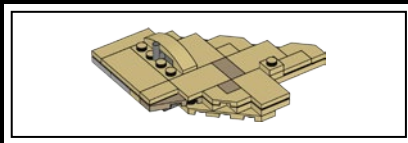

335

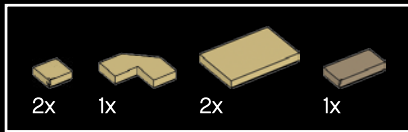
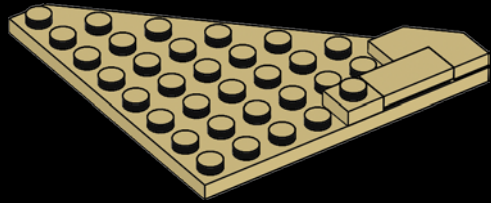

336

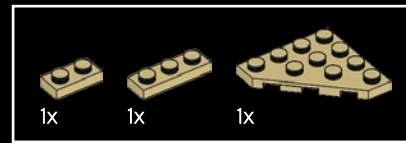
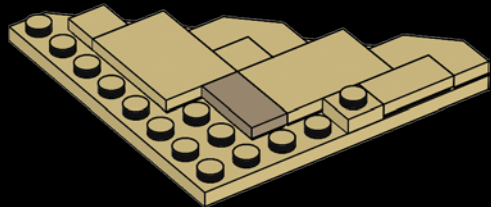

337

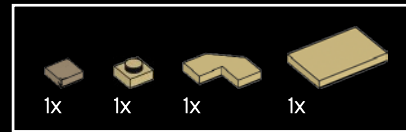
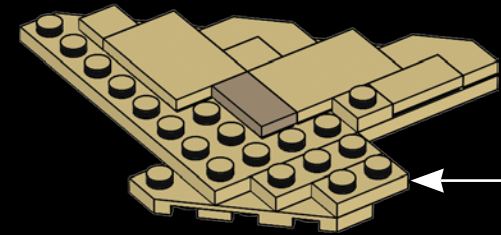

338

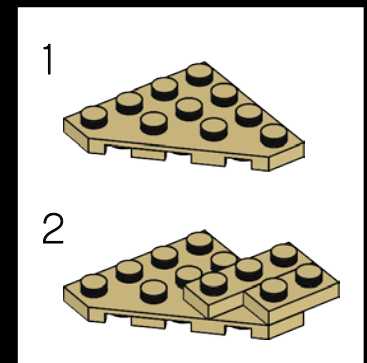
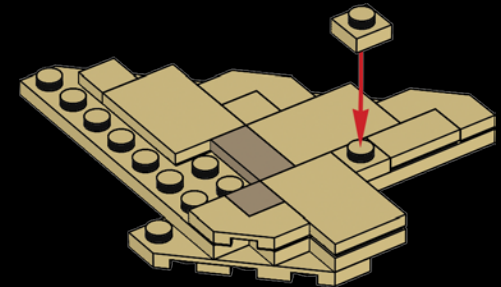

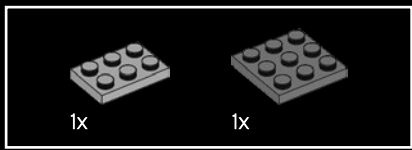

339

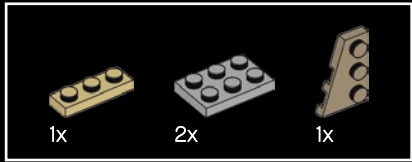
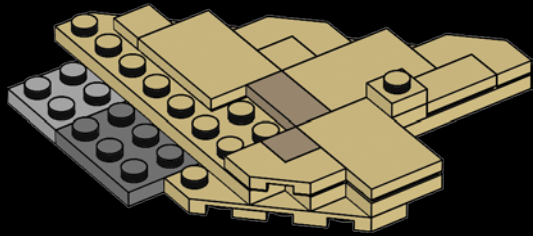

340

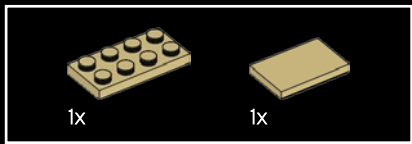
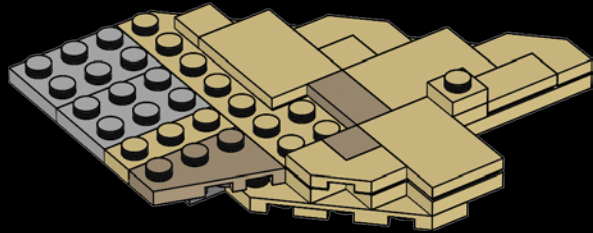

341

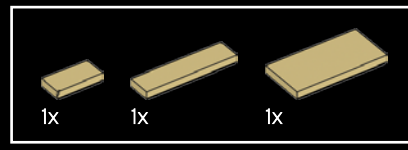
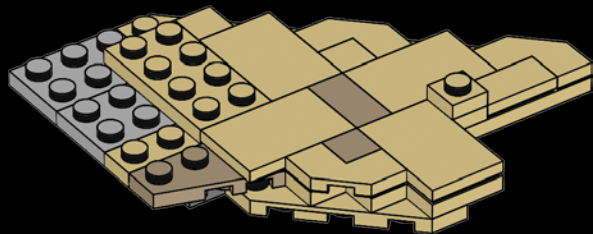

342

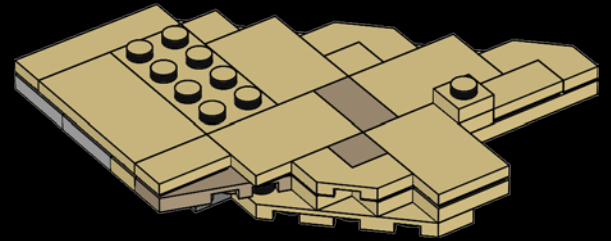

343

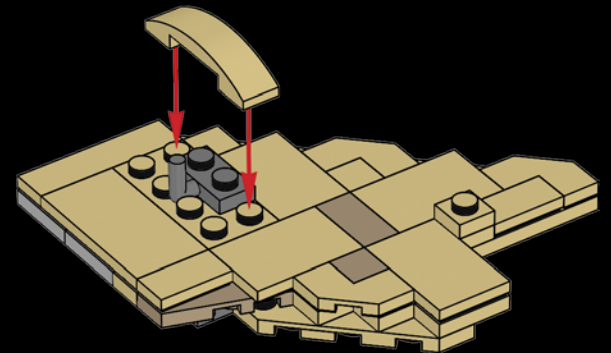

344

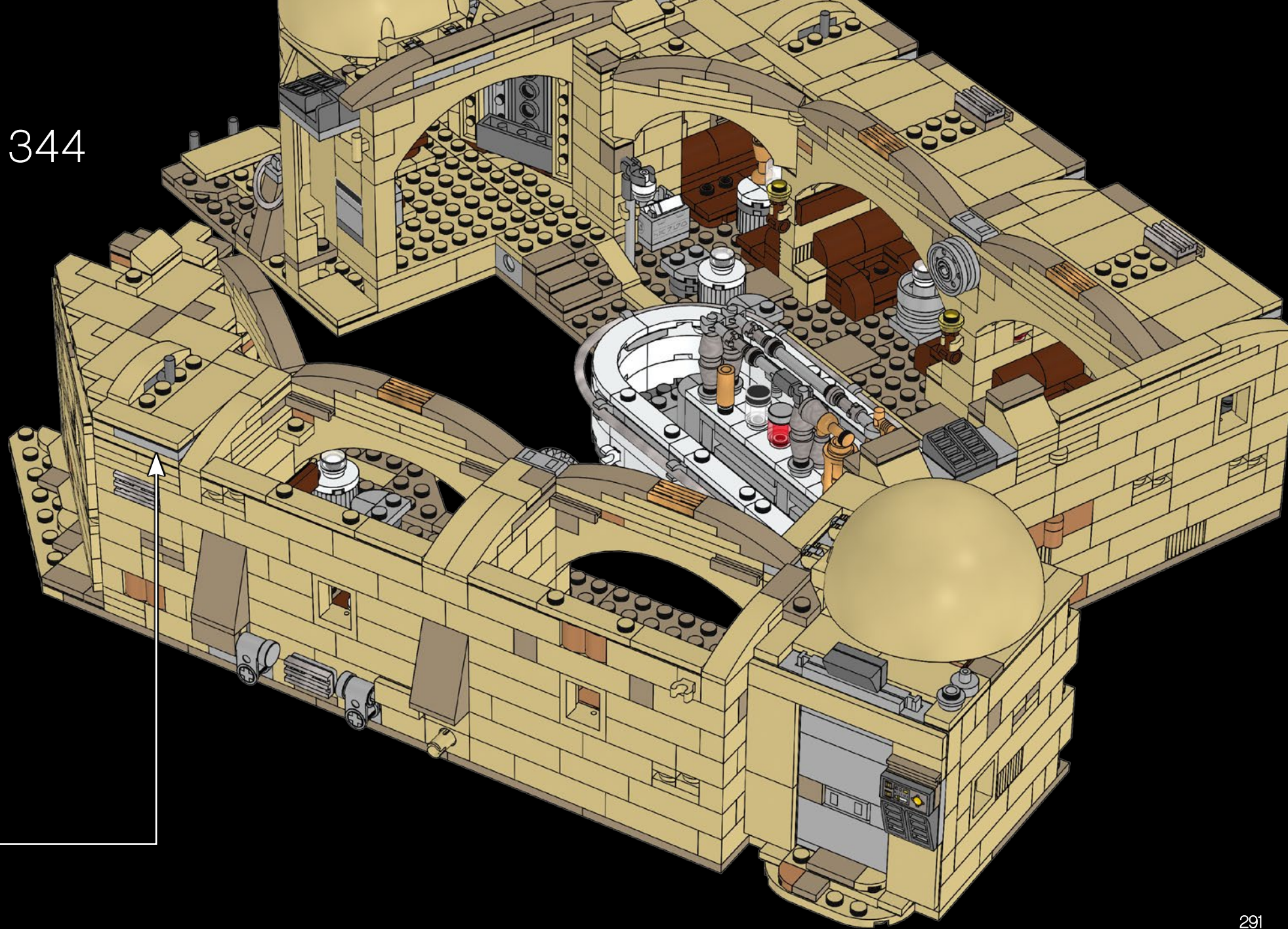

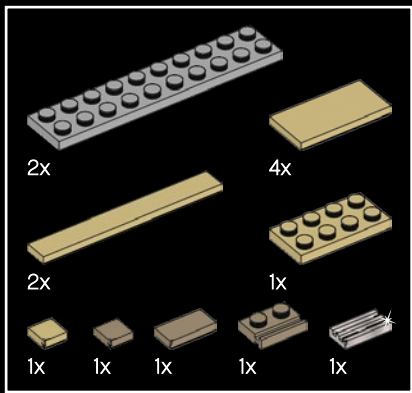

345

1

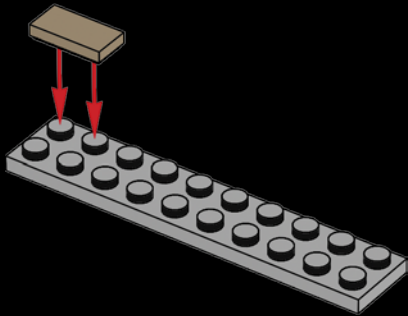

2

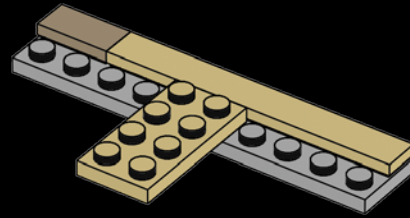

3

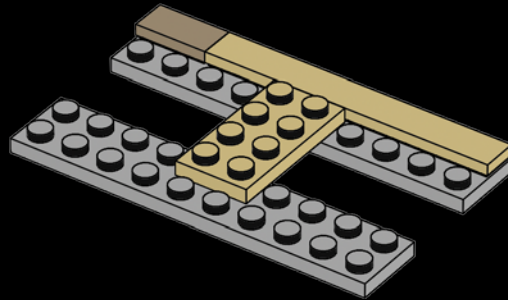

4

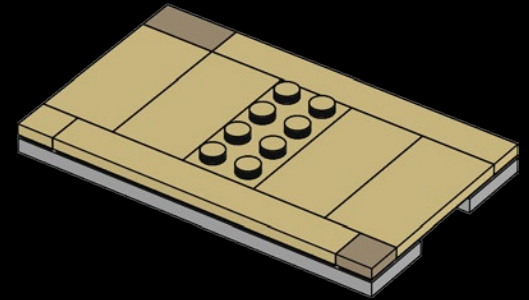

5

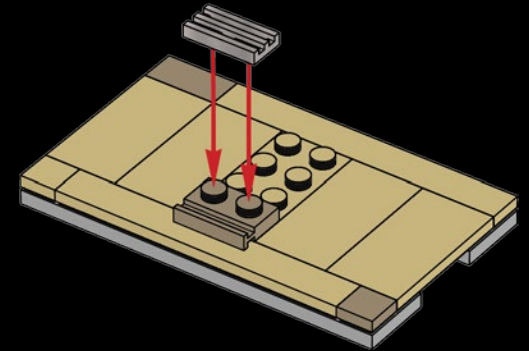

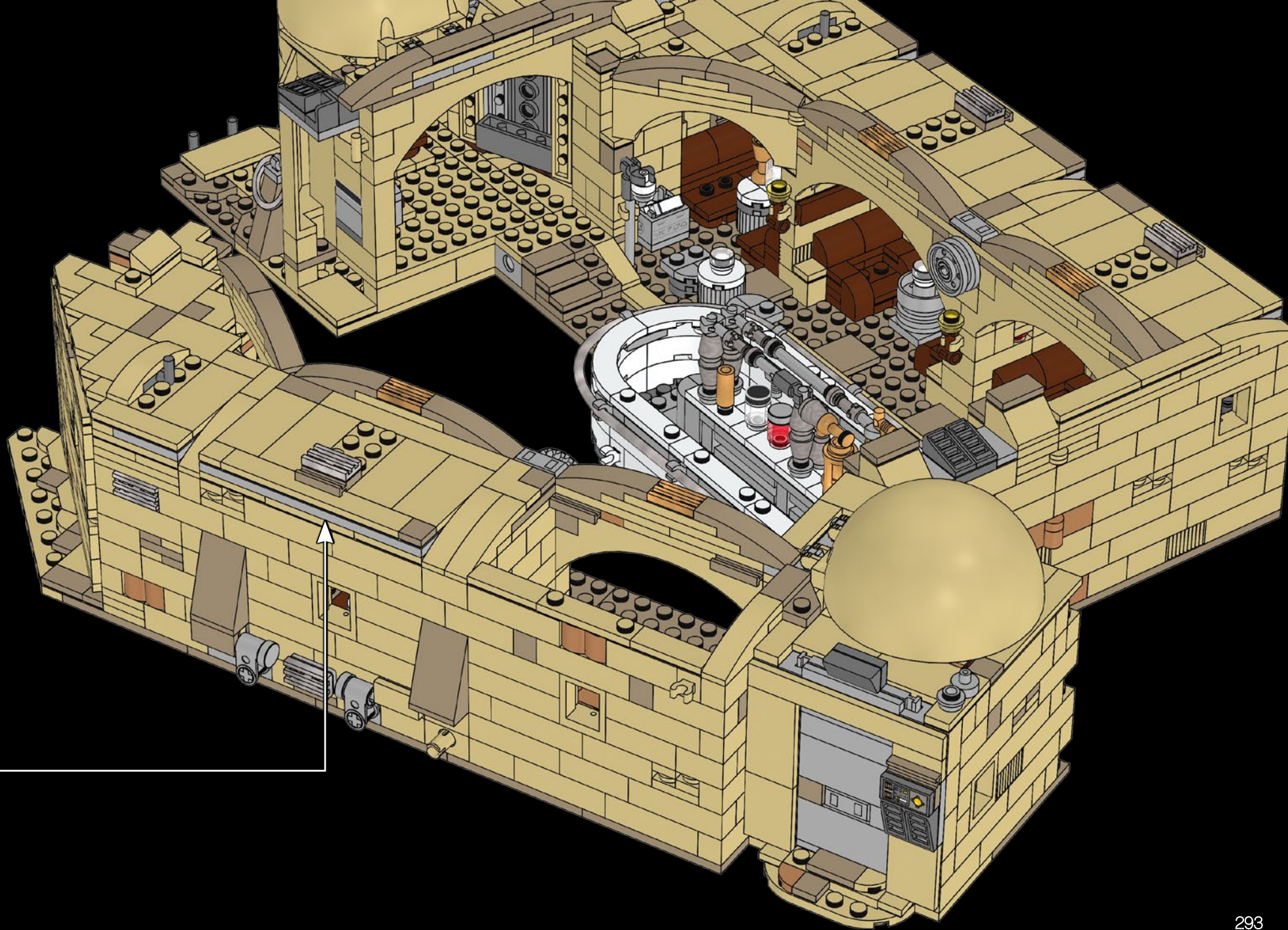

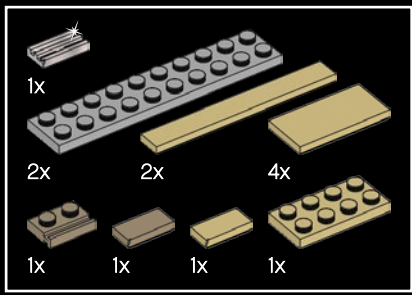

346

1

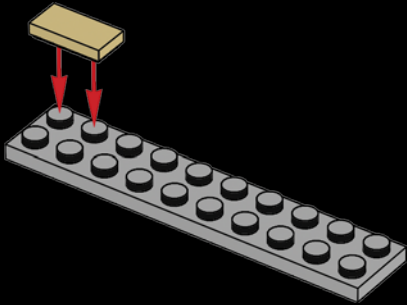

2

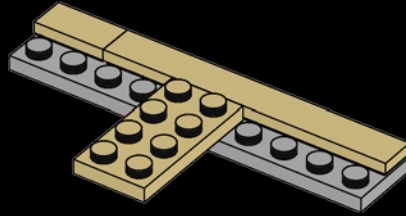

3

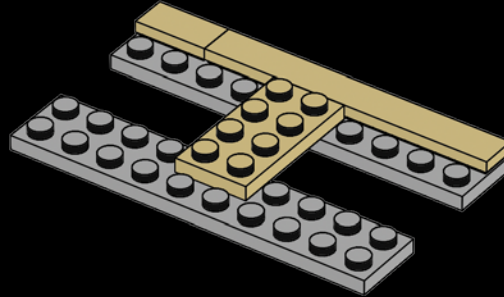

4

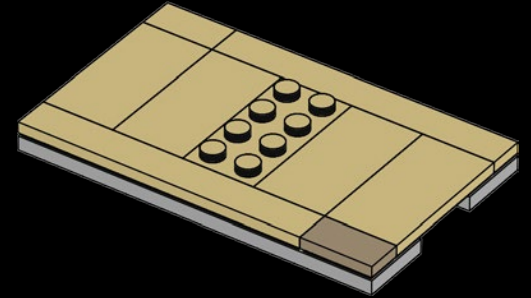

5

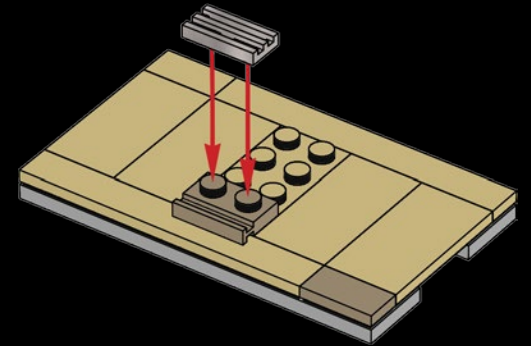

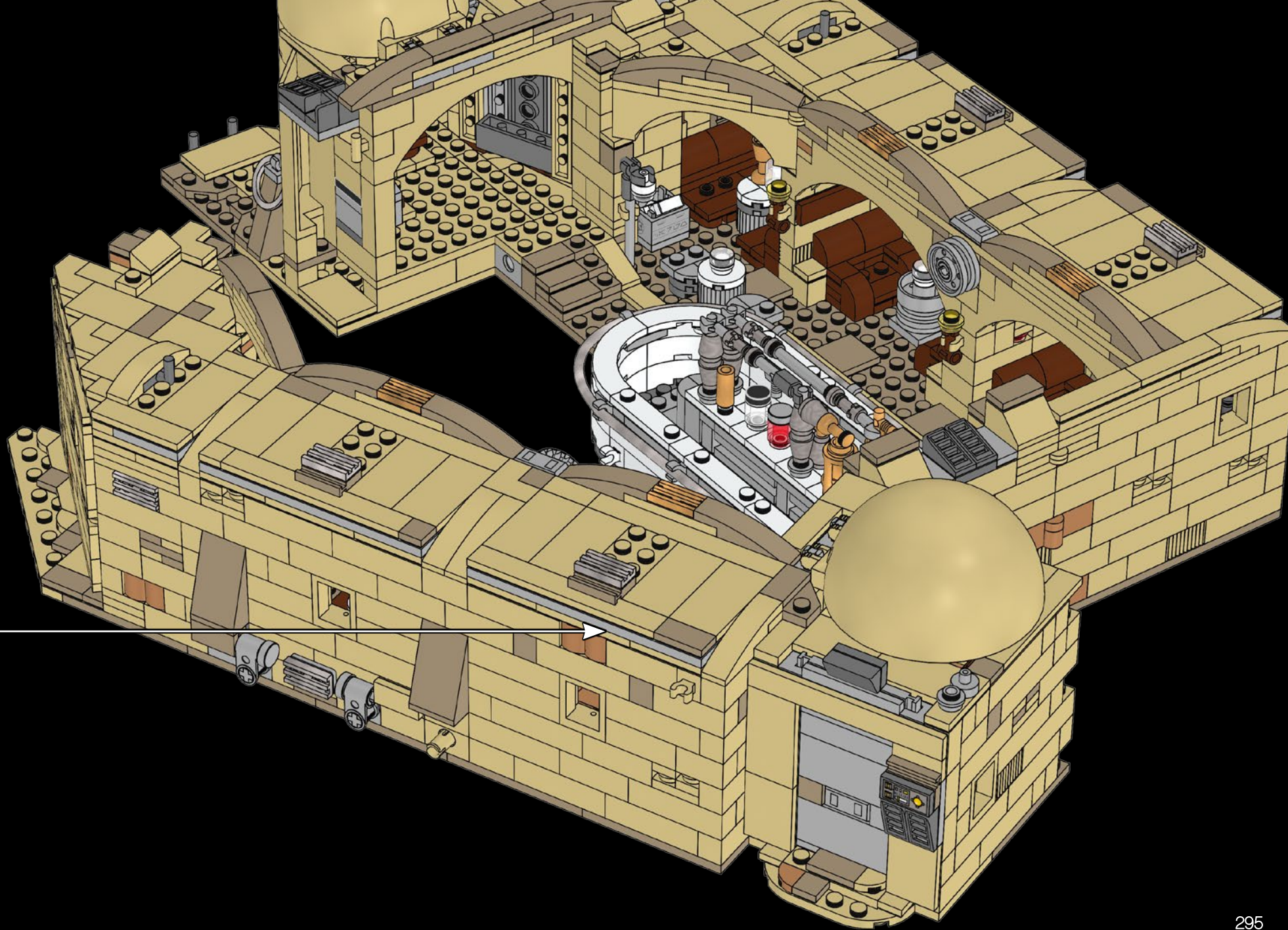

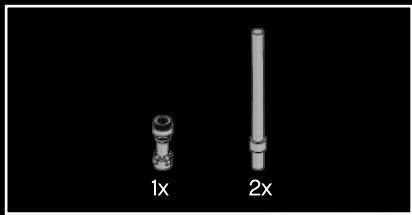

347

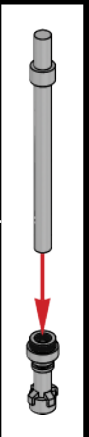
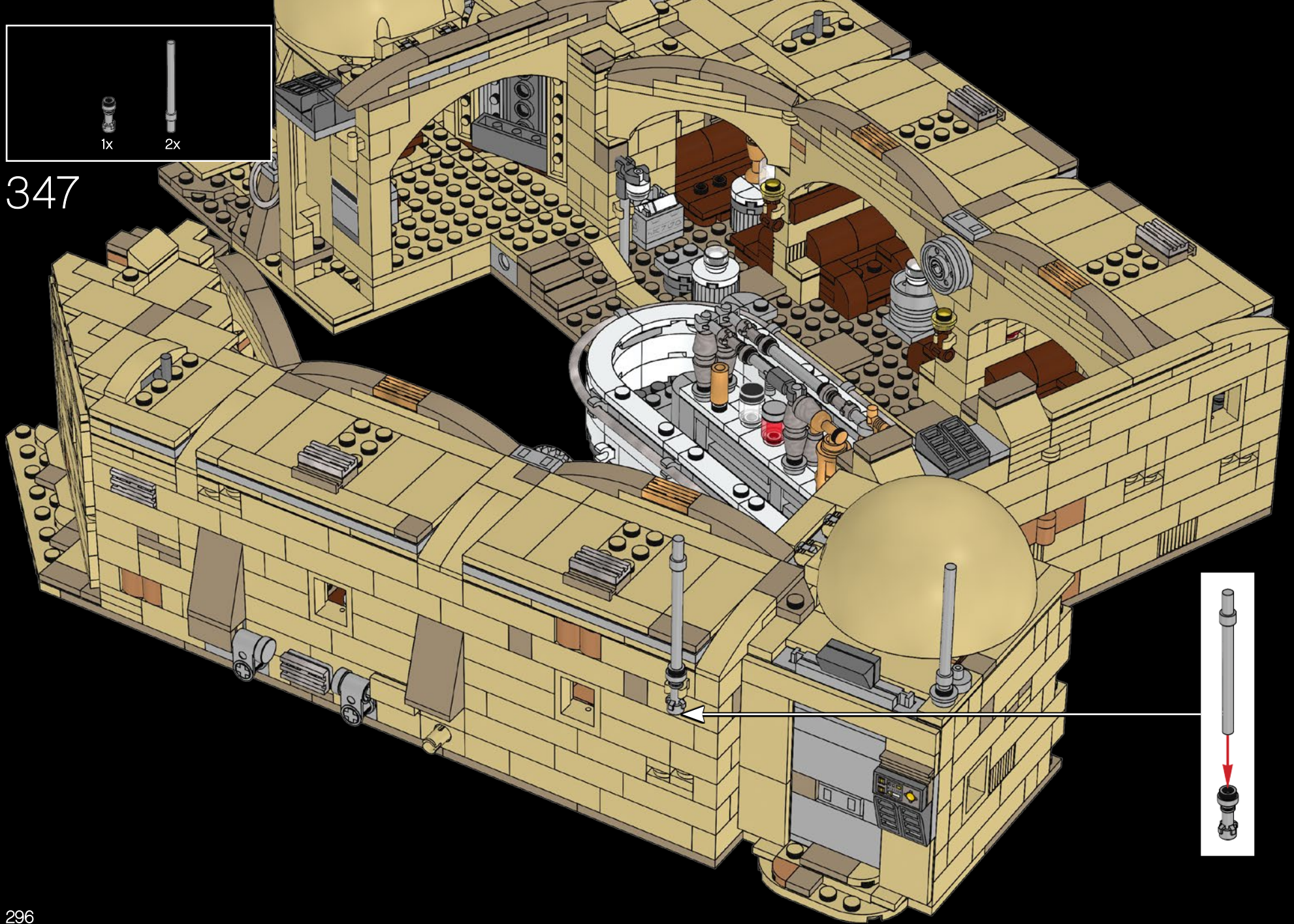

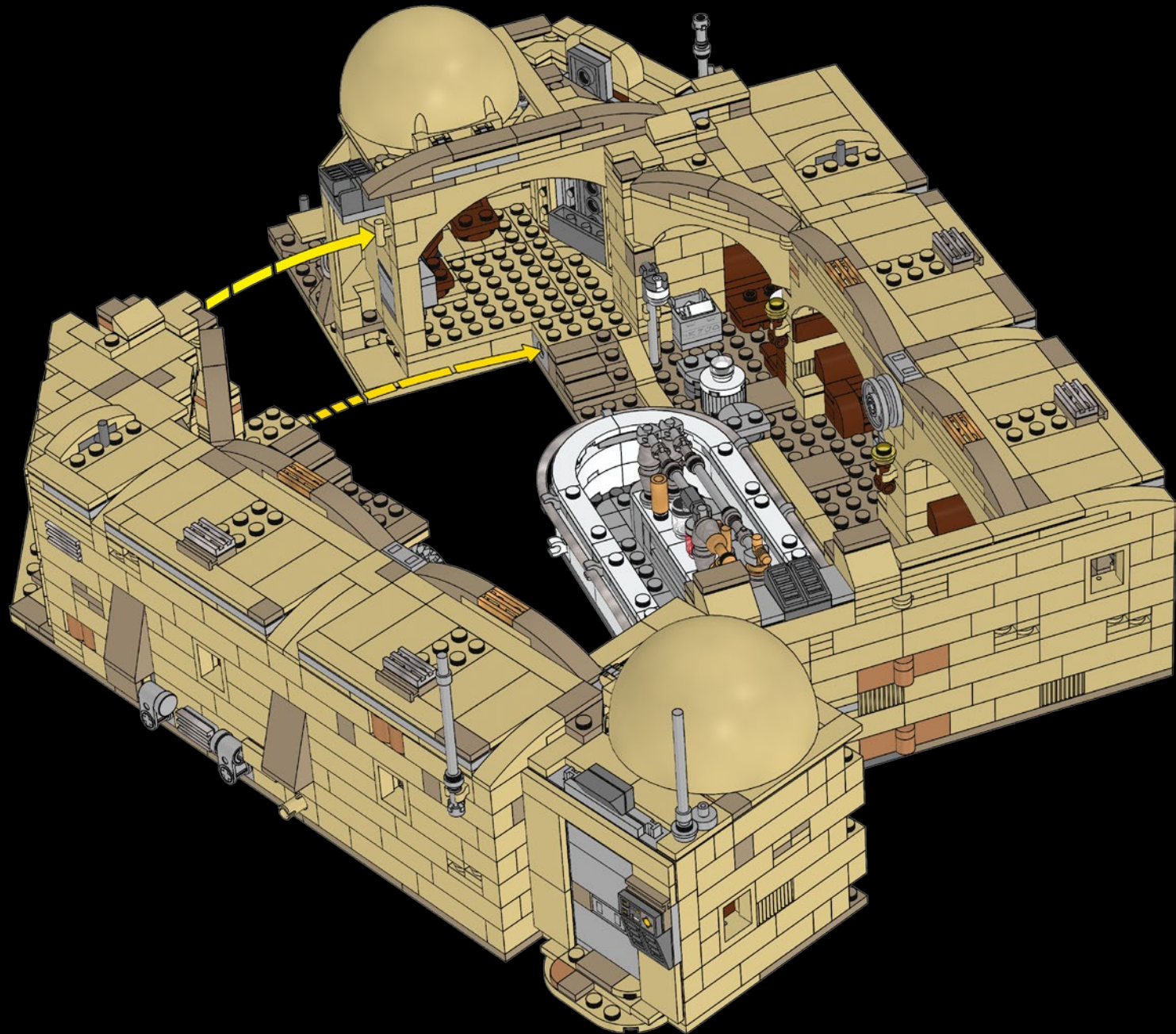



15

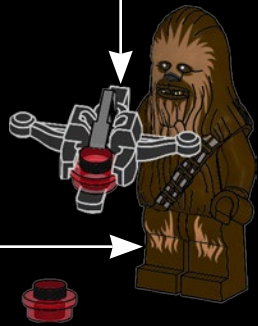
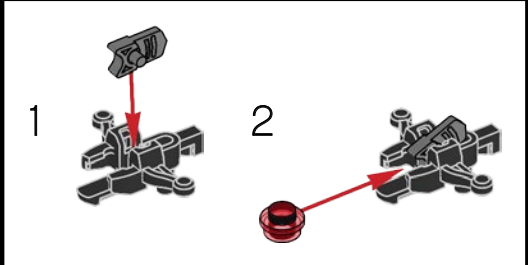
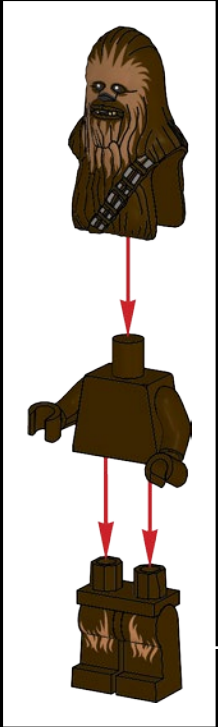
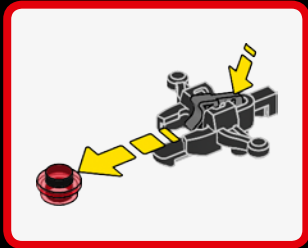
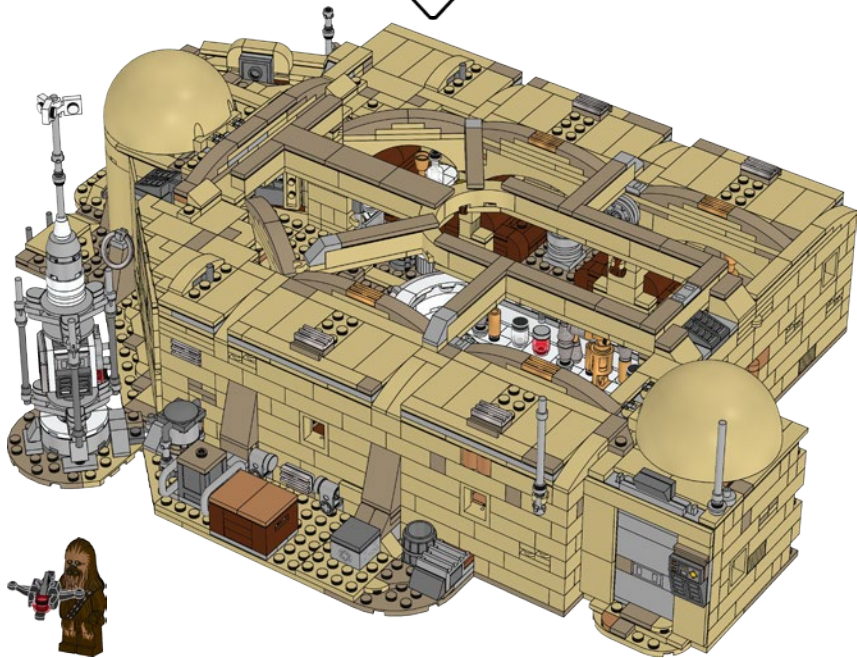
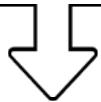

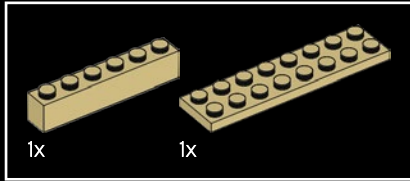
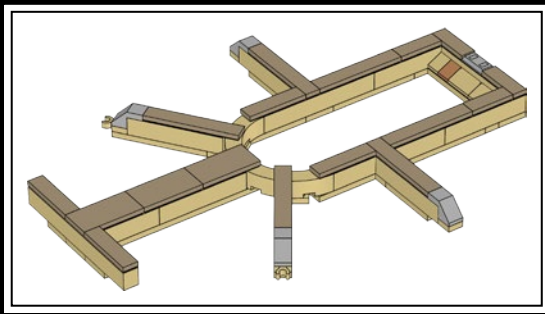

348

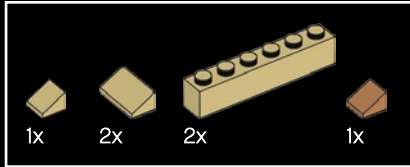
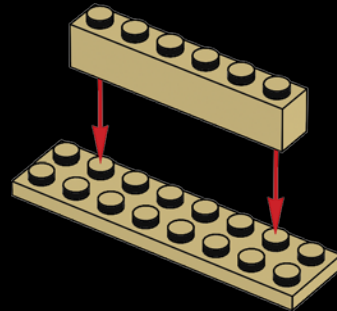

349

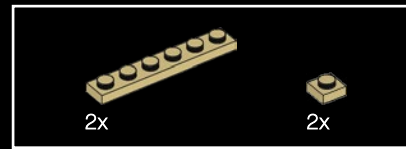
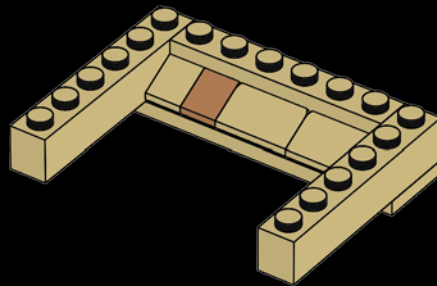

350

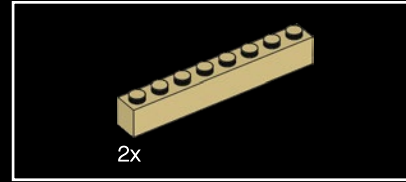
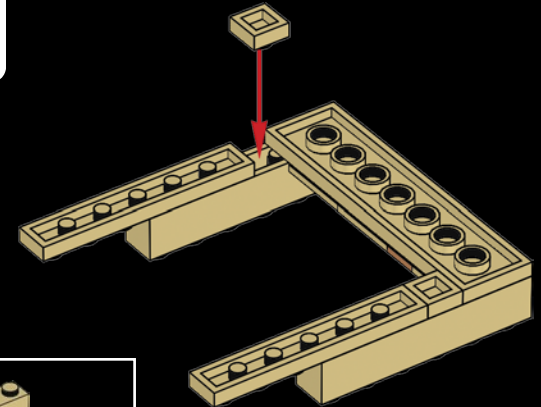

351

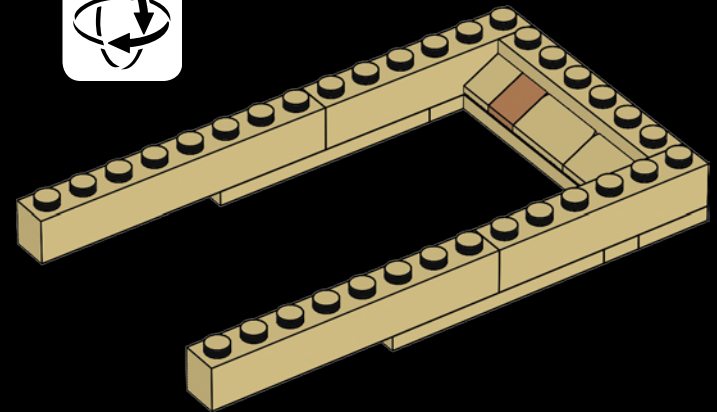
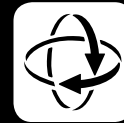

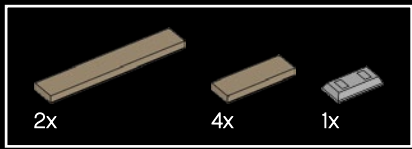

352

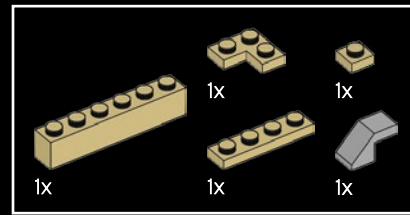
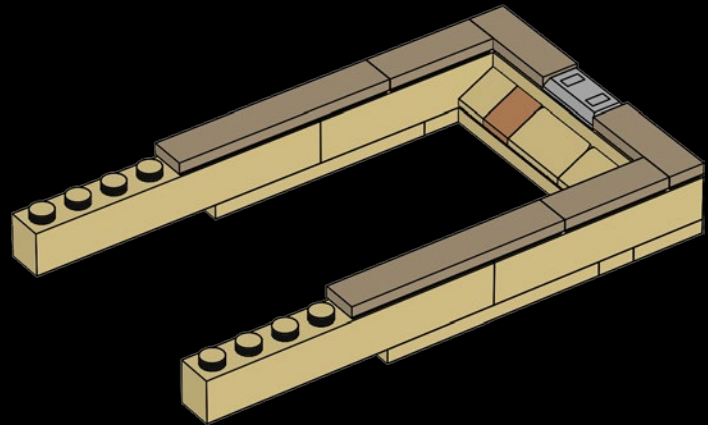

353

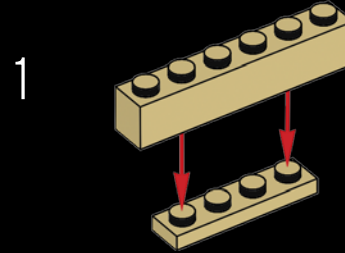

2

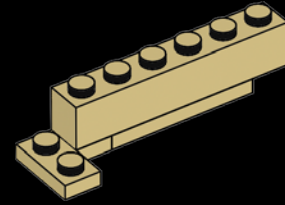

3

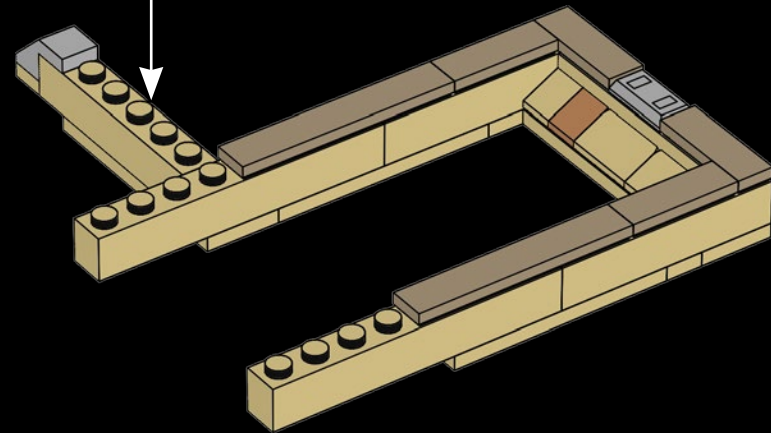
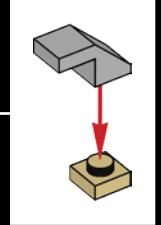
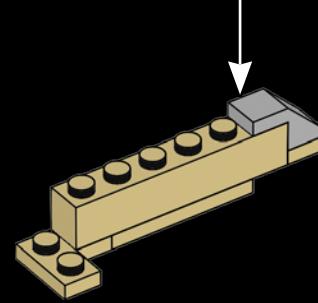

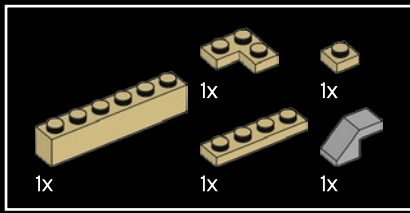

354

1

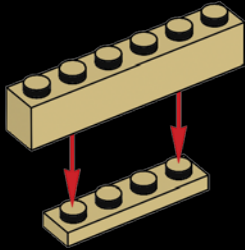

2

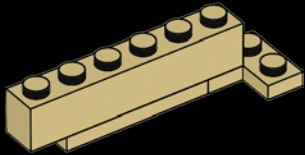

3

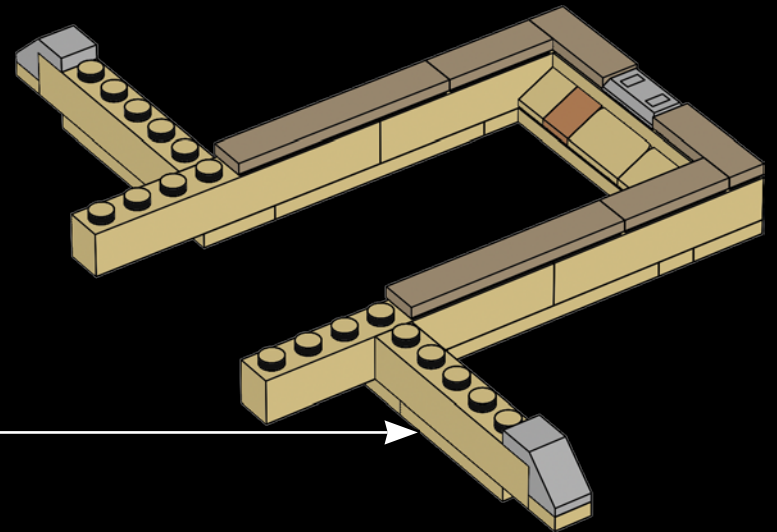
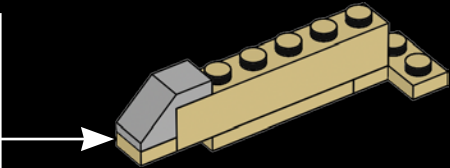
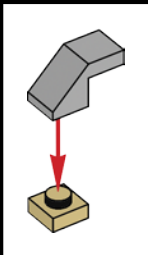

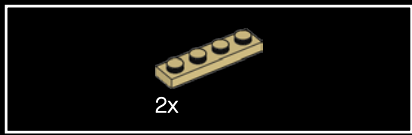

355

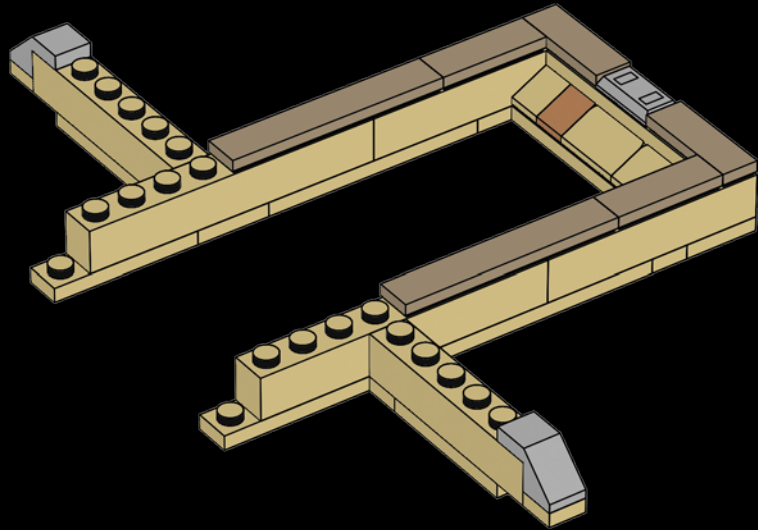

356

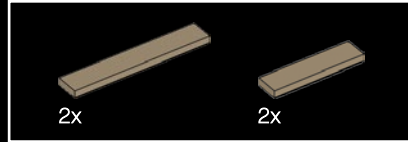
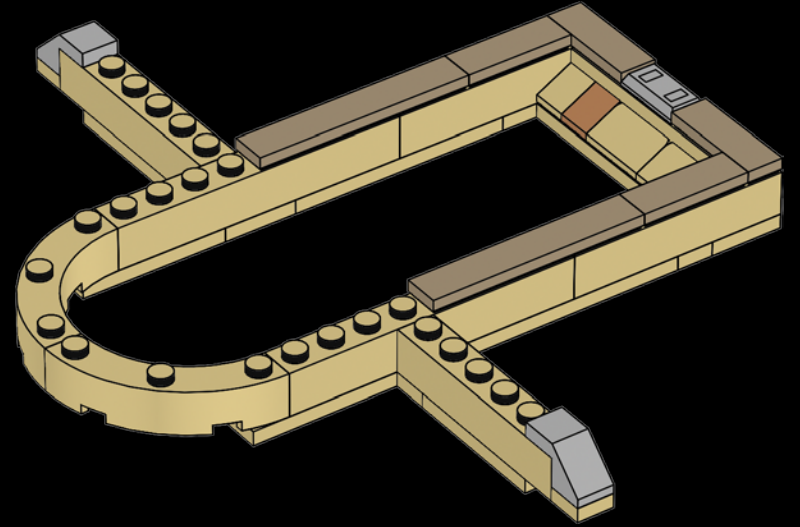

357

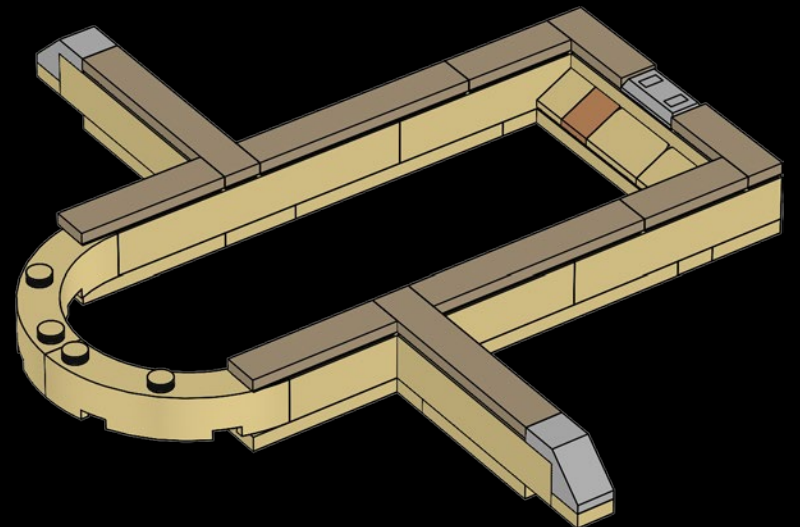

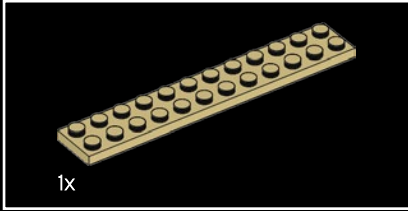
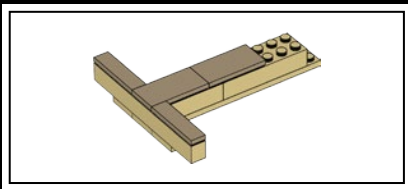

358

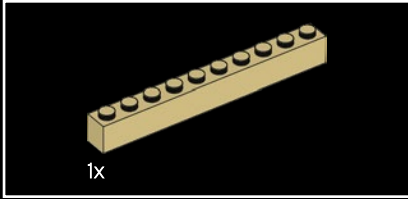

359

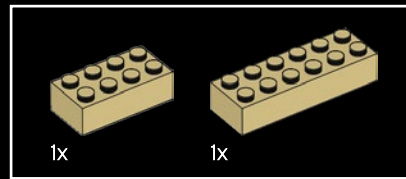
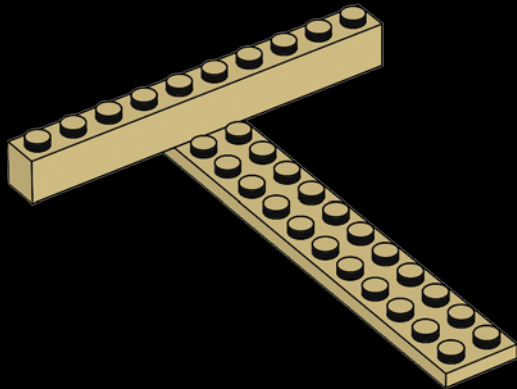
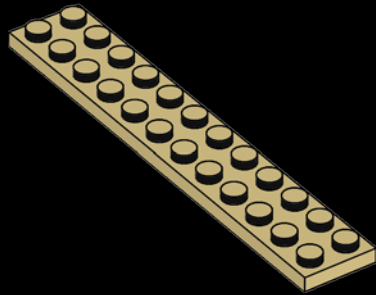

360

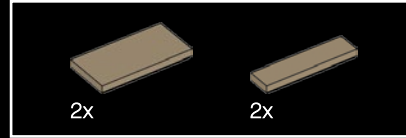
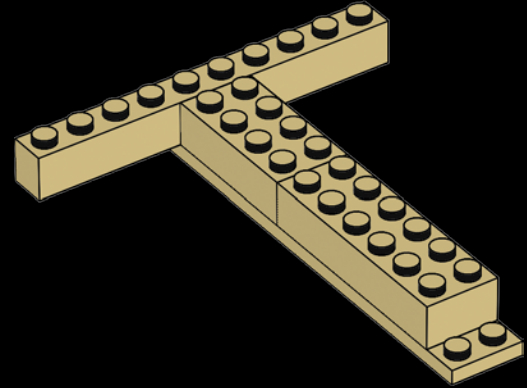

361

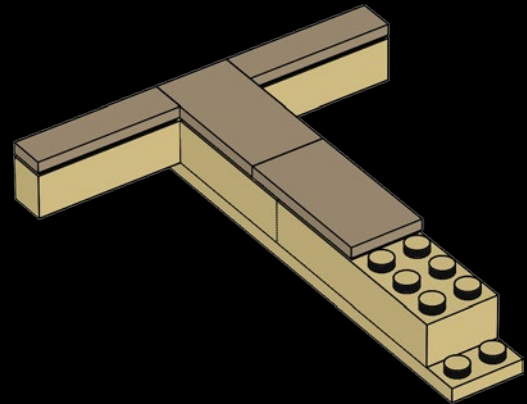



2x

362

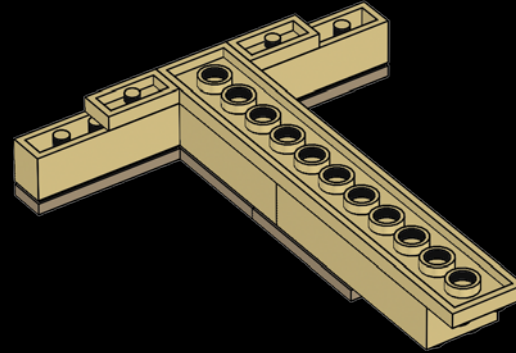

363

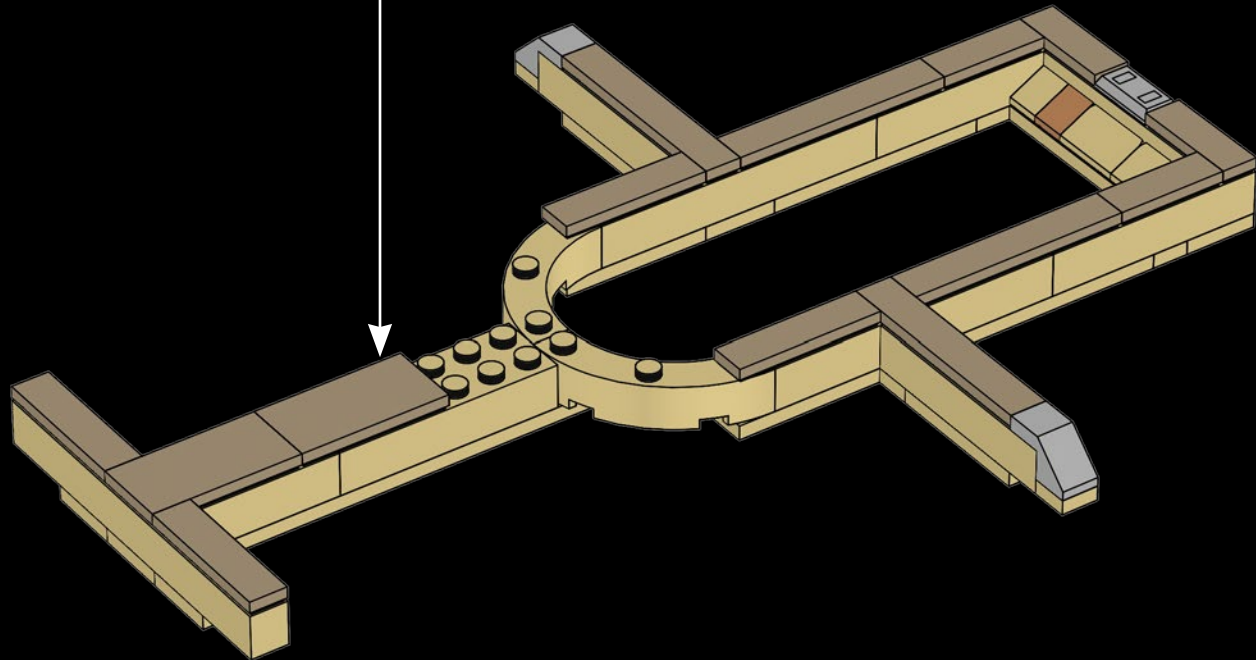

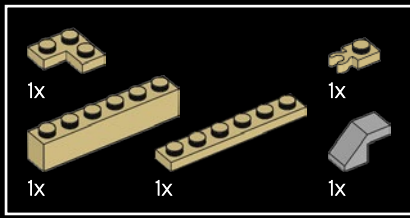

364

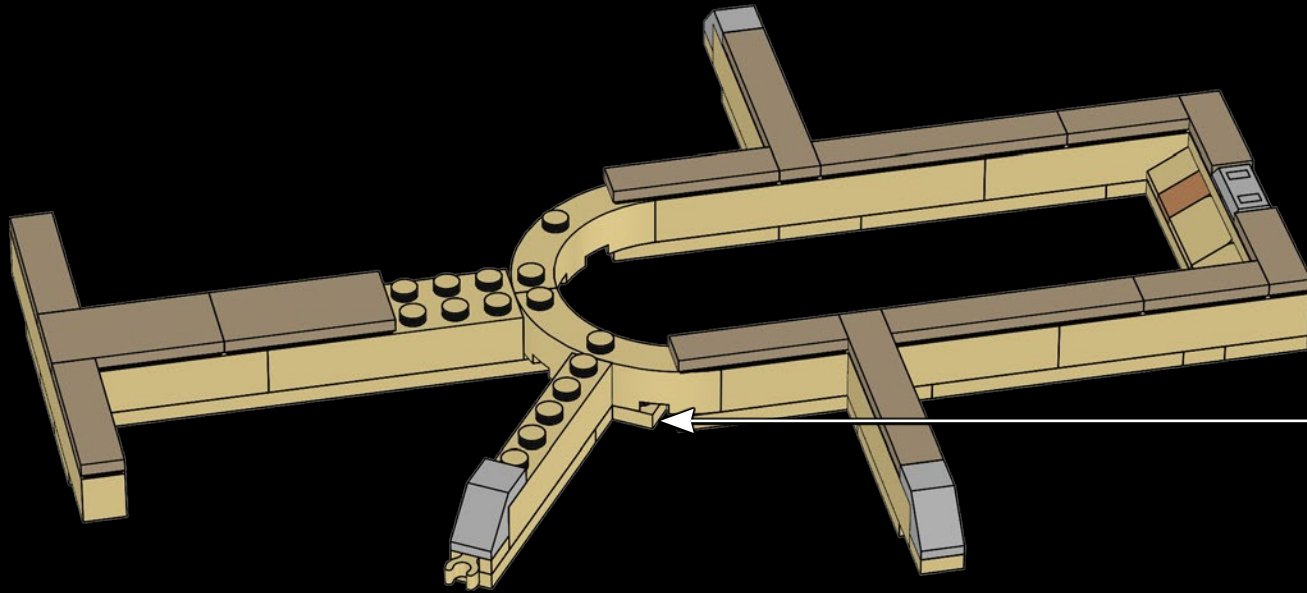
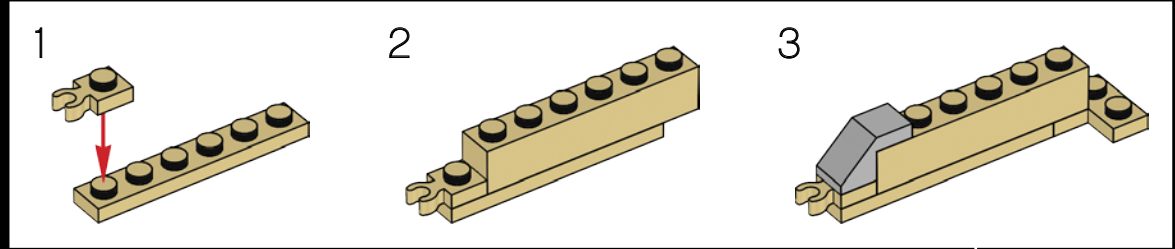

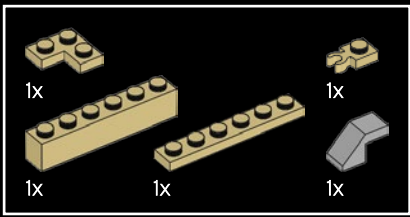

365

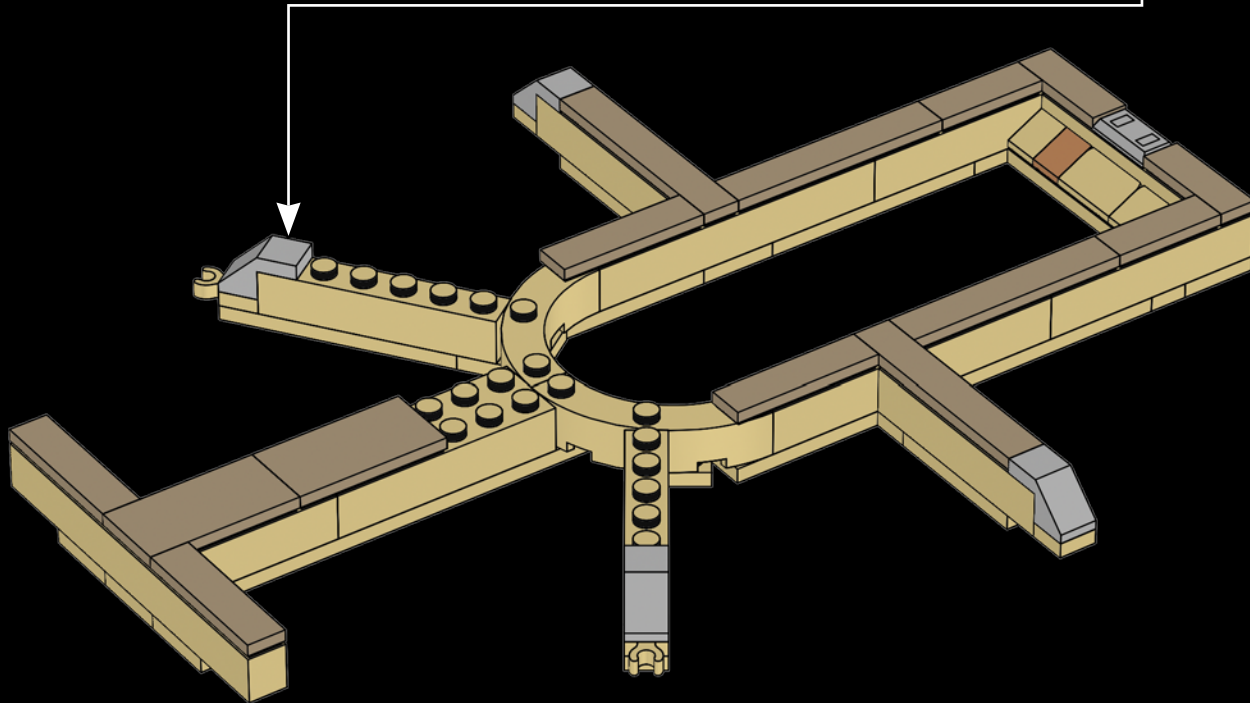
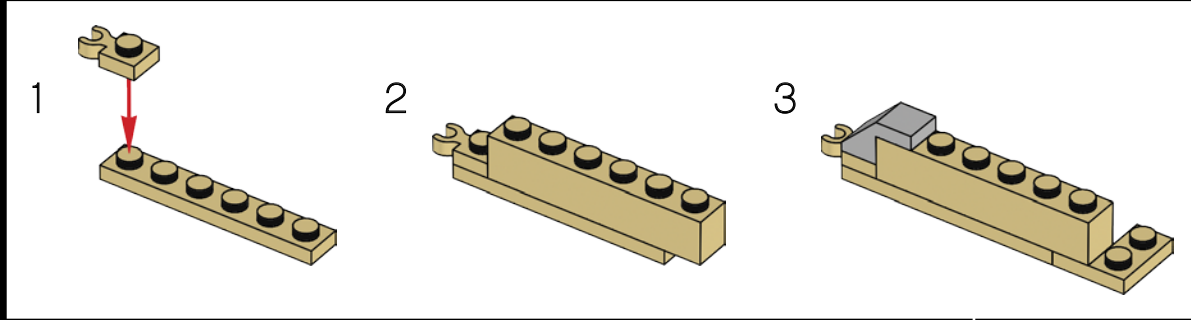

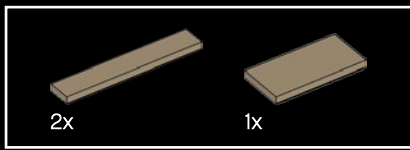

366

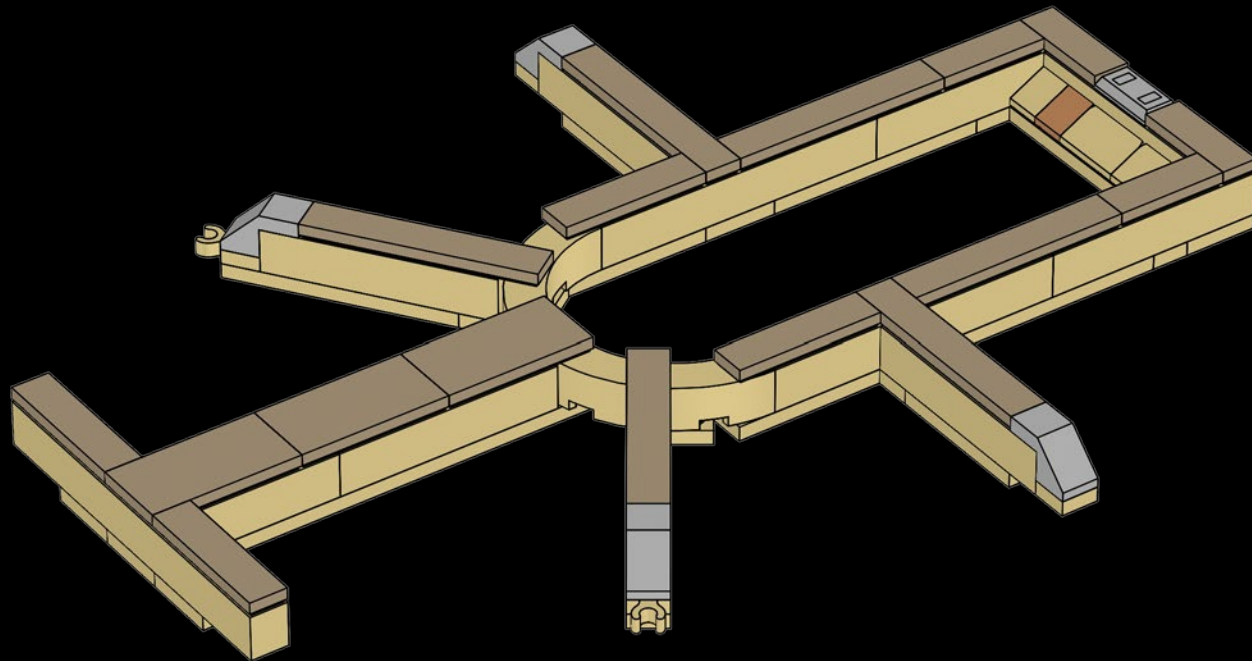

367

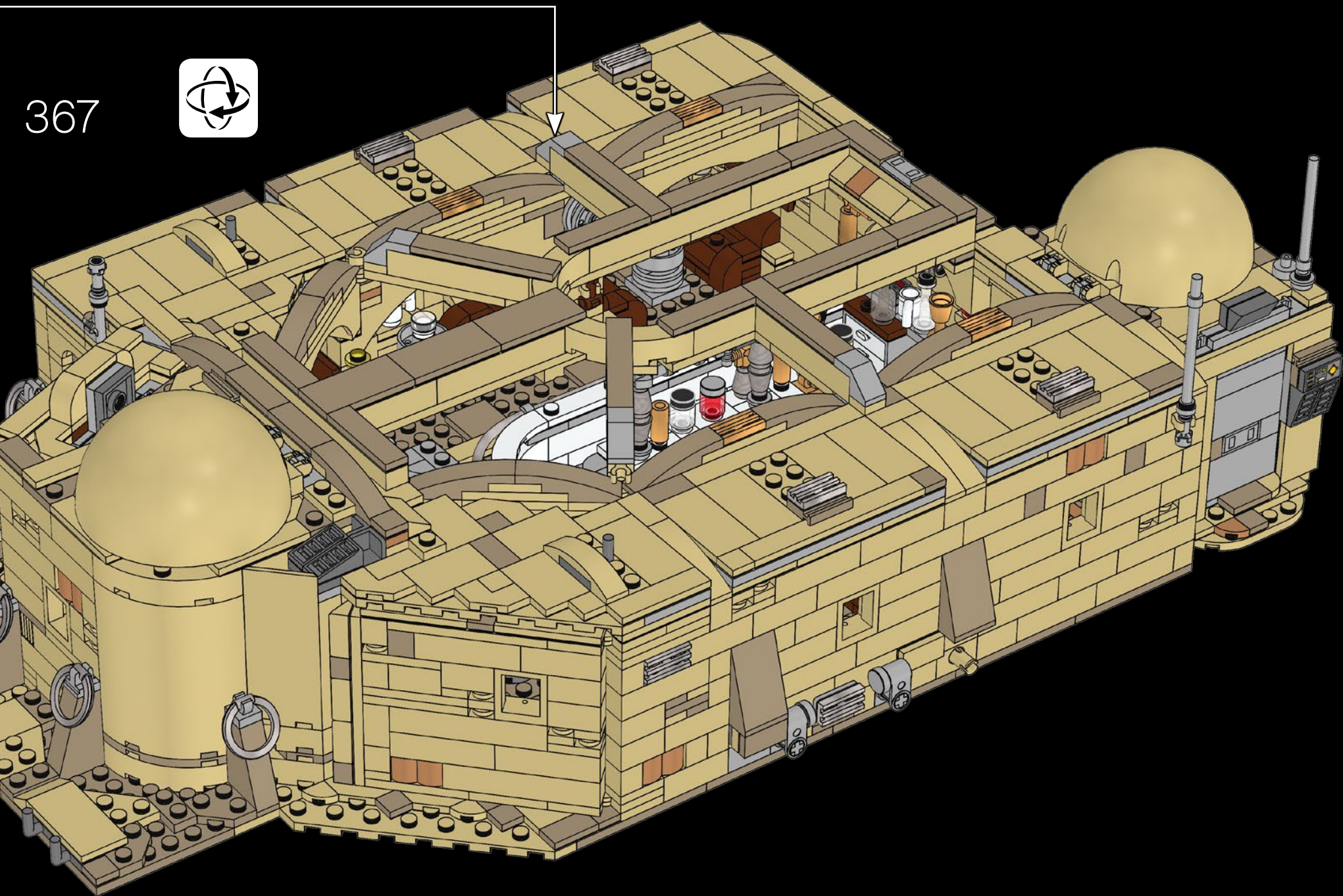

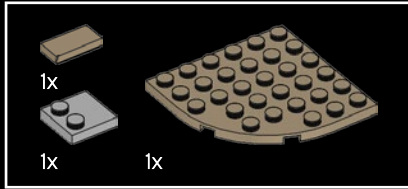
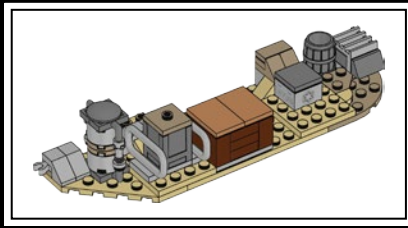

368

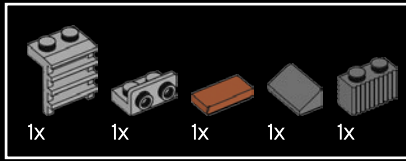
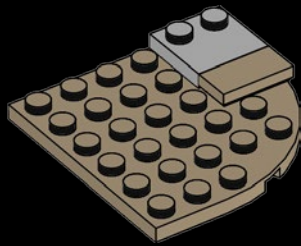

369

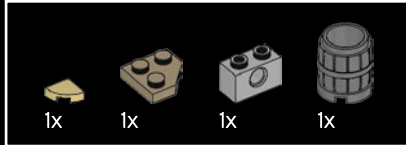
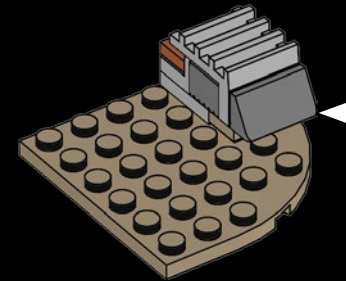
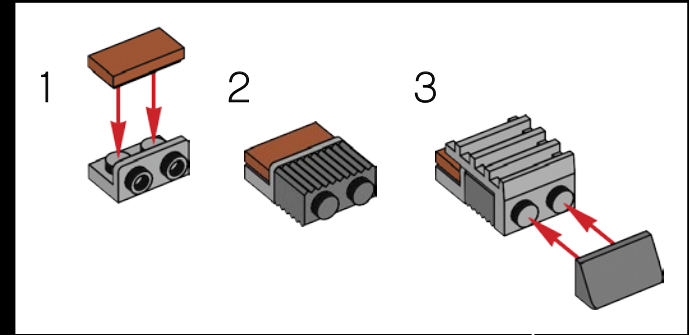

370

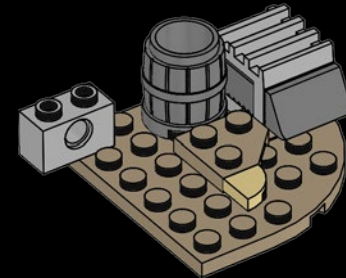

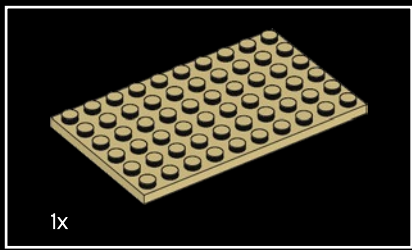

371

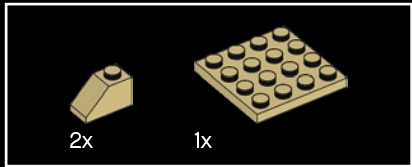
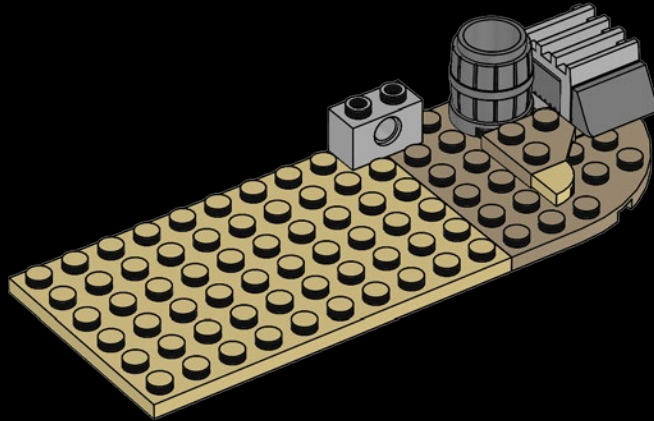

372

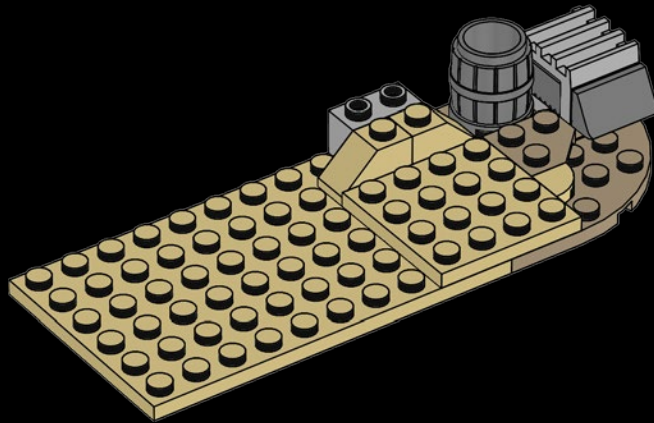

373

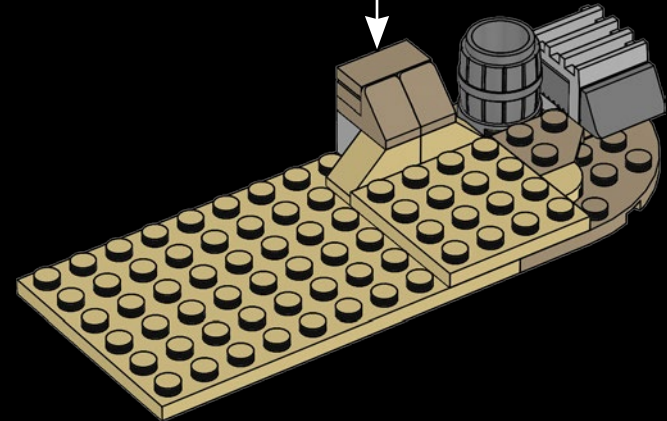
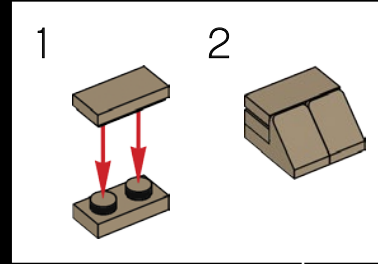

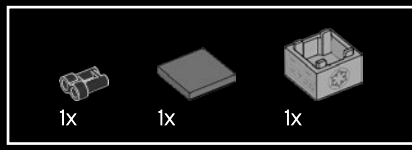

374

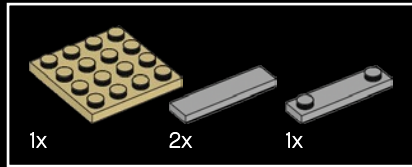
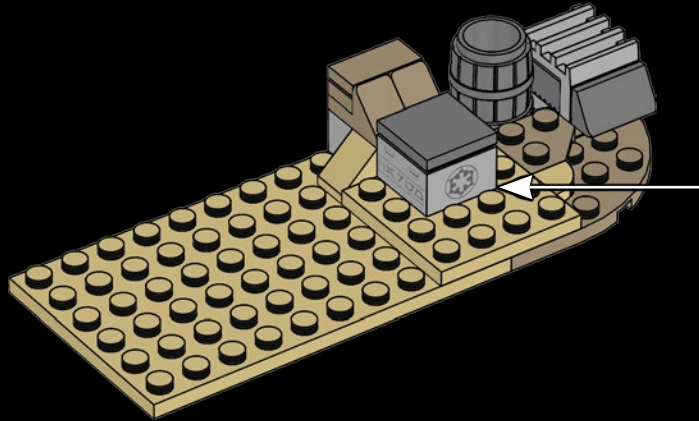
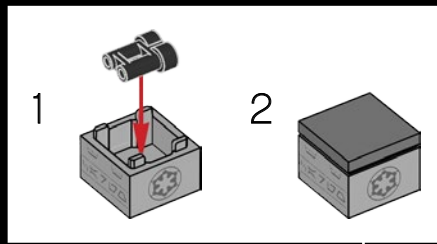

375

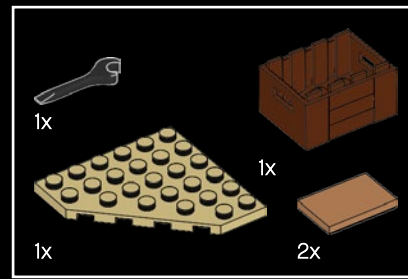
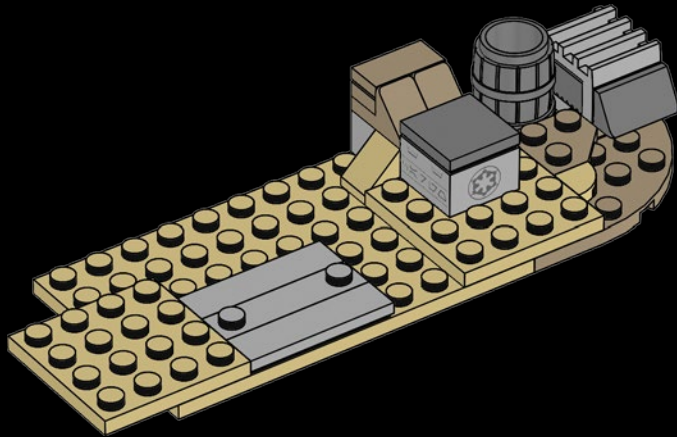

376

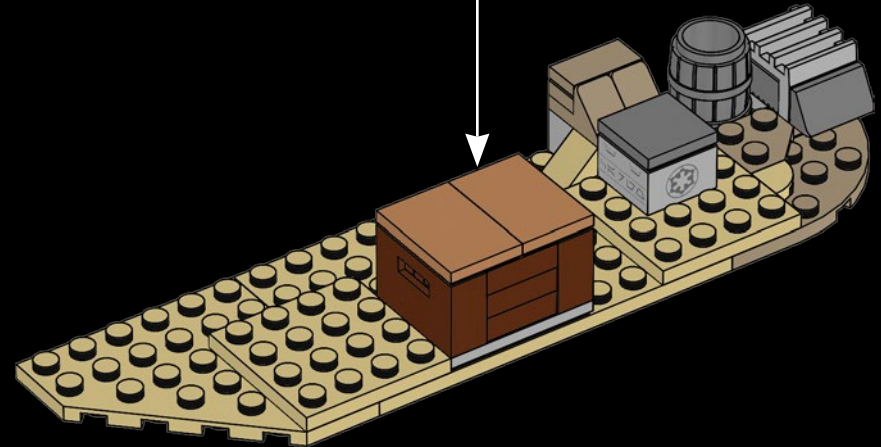
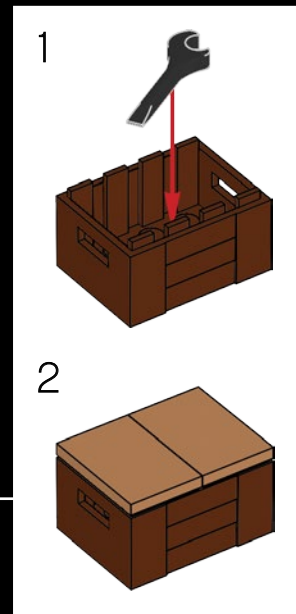

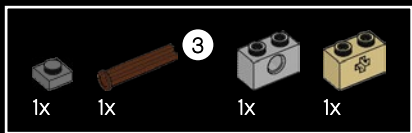

377

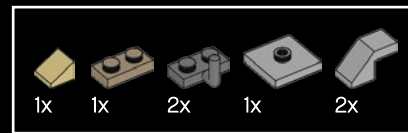
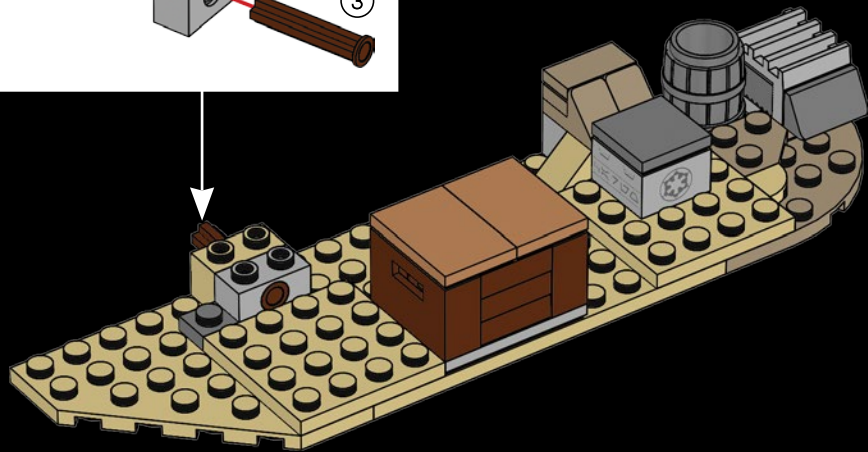
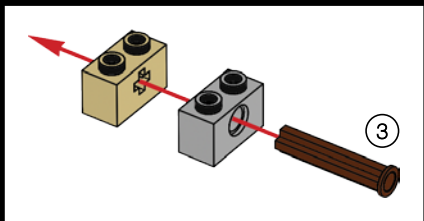

378

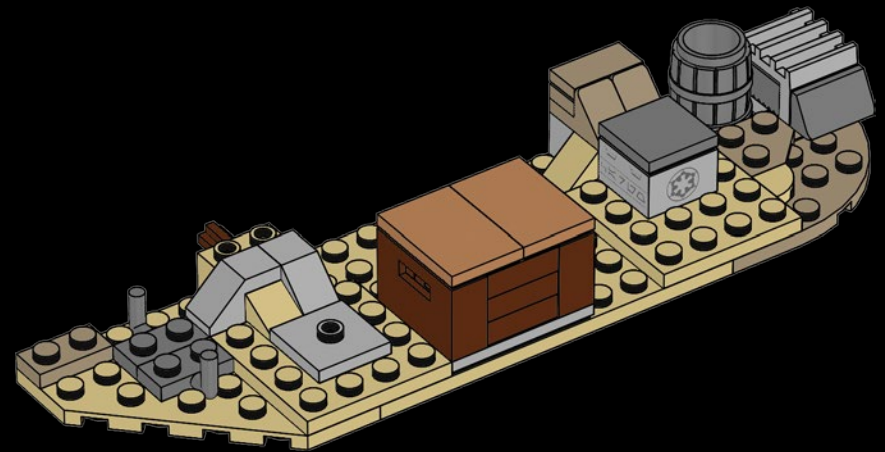

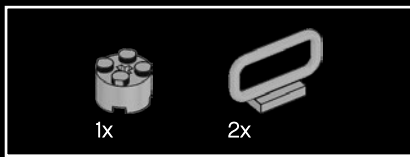

379

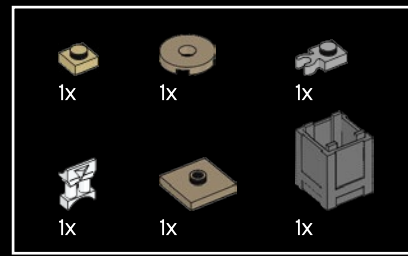
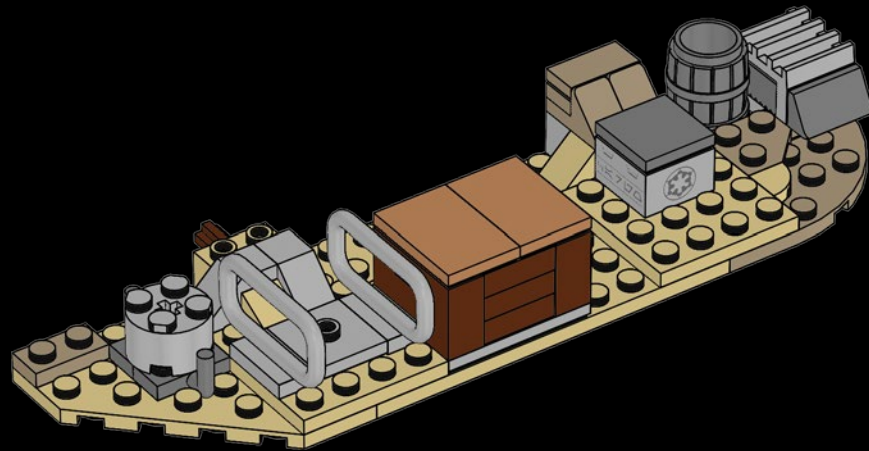

380

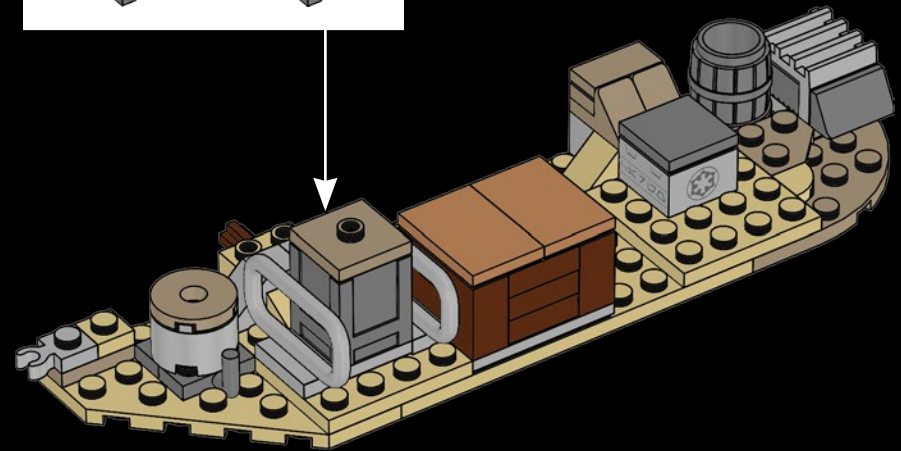
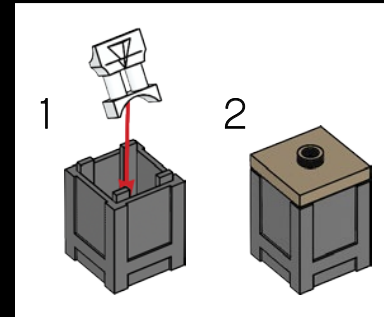

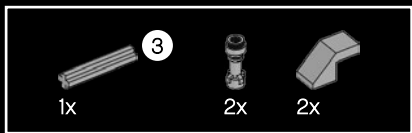

381

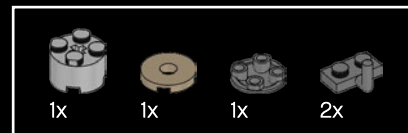
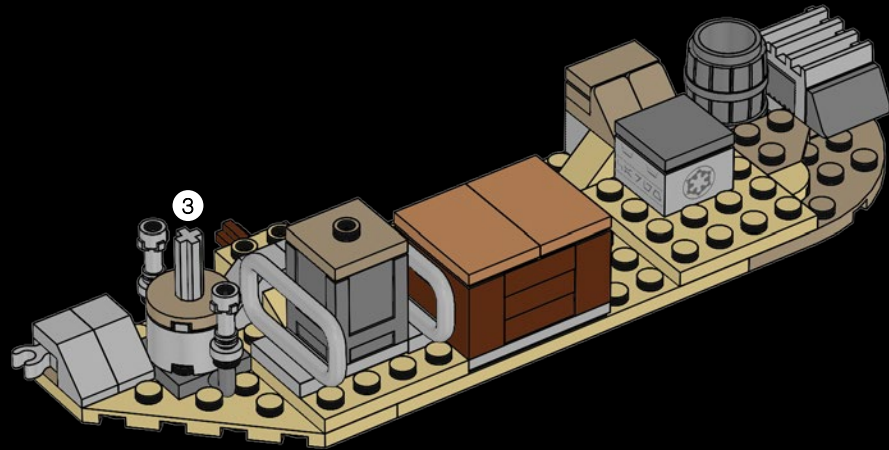

382

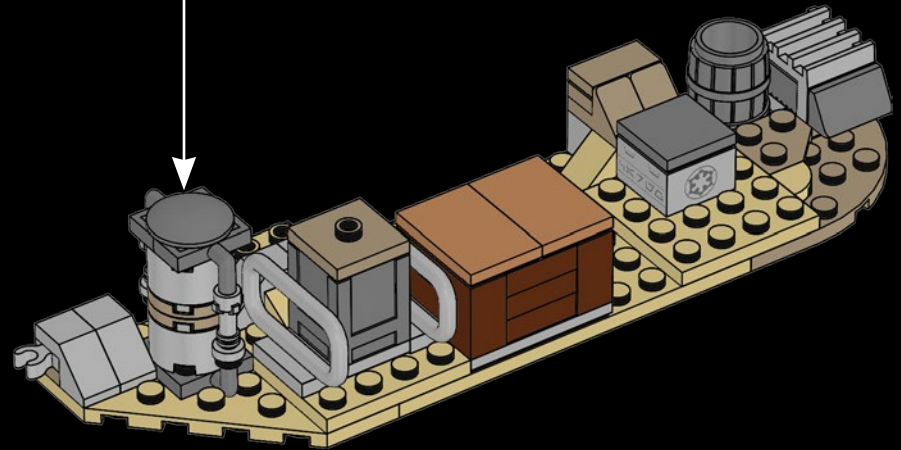
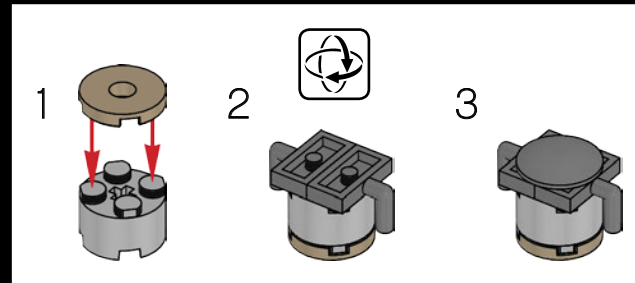

383

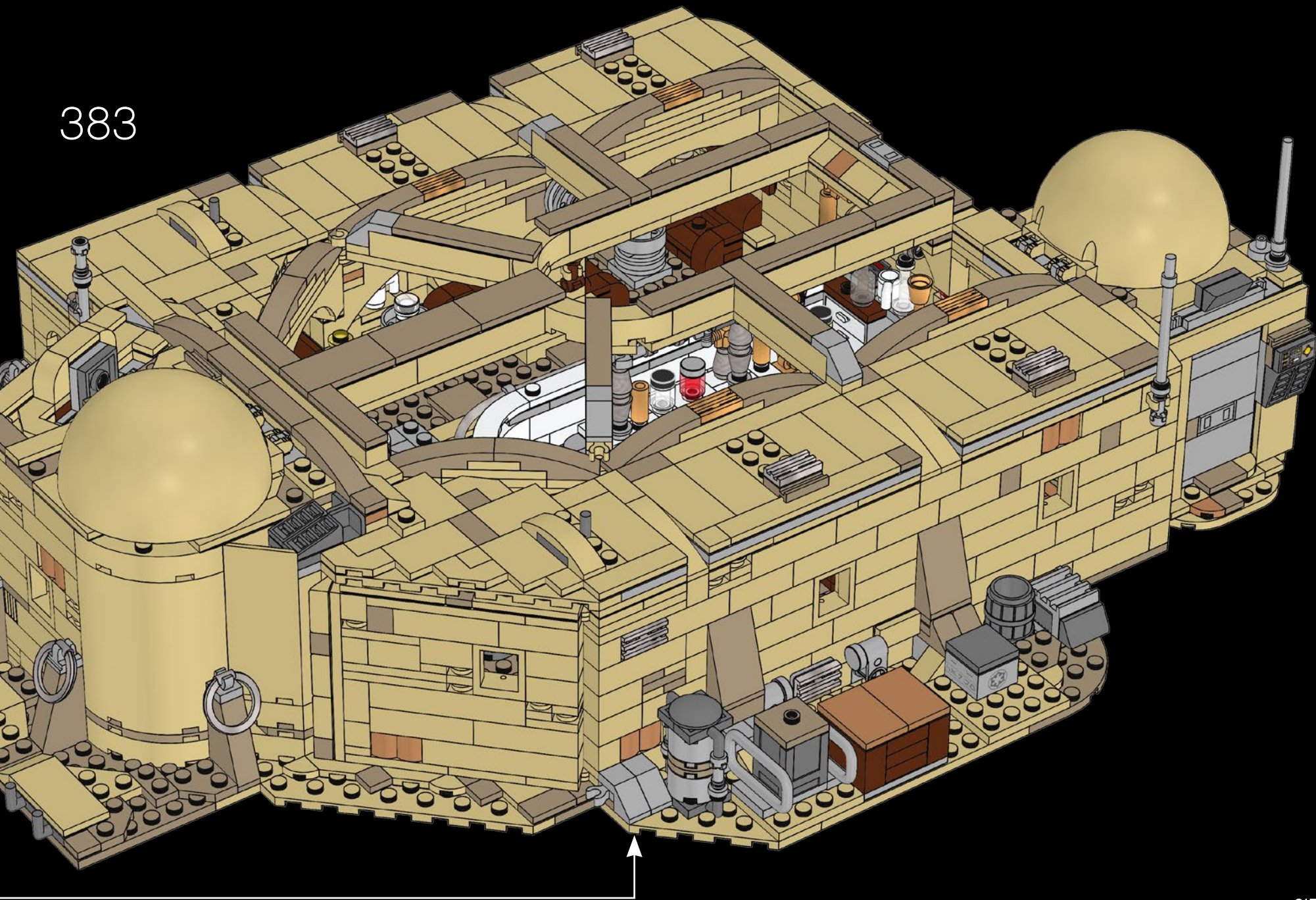

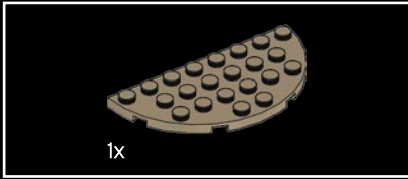

384

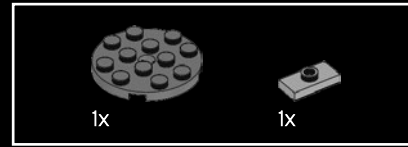
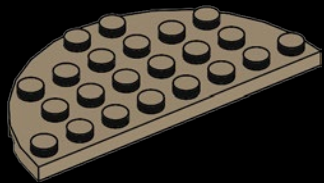

385

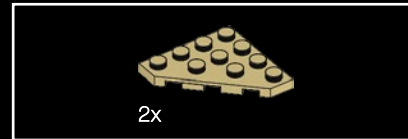
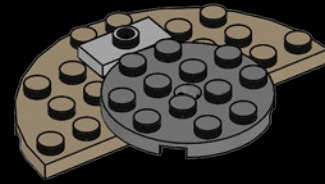

386

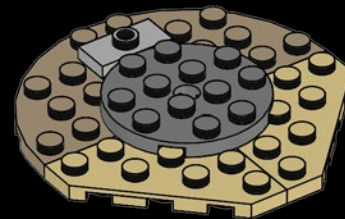



387

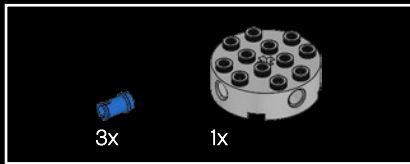
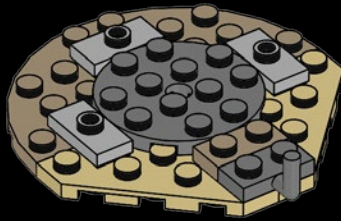

388

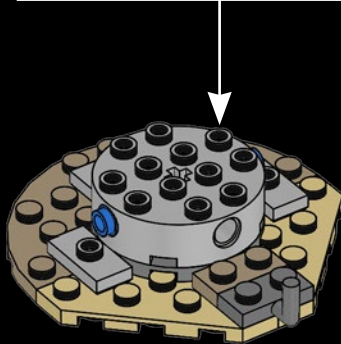
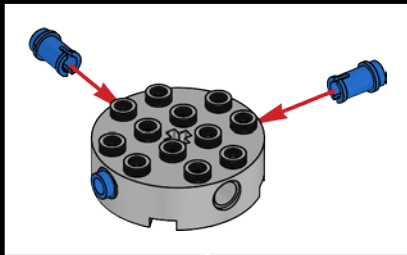

389

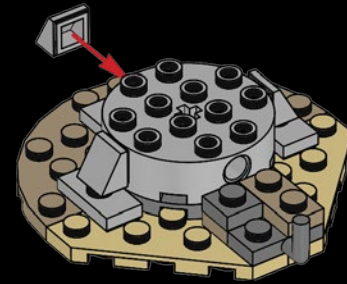

390

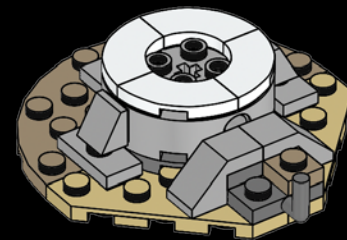

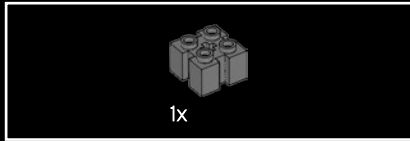
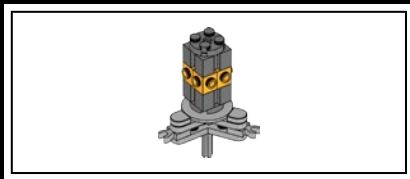

391

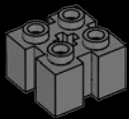

392

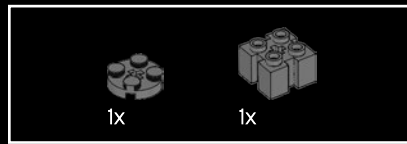

393

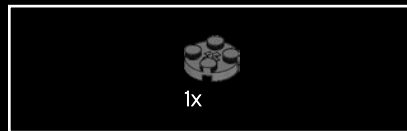
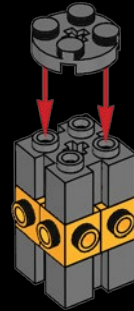

394

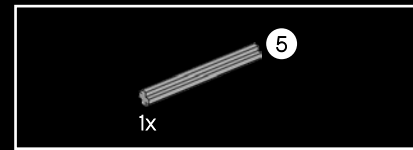
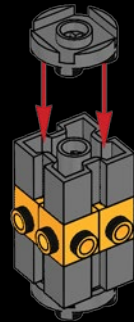

395

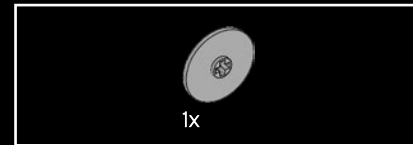

396

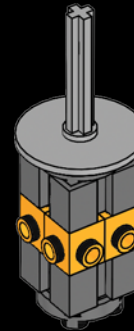



397

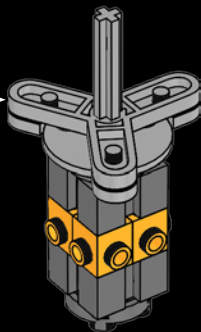
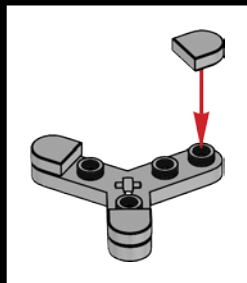

398

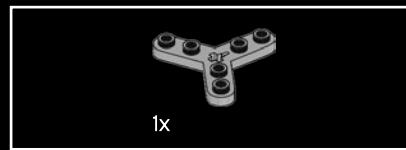
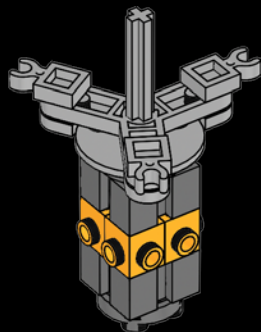

399

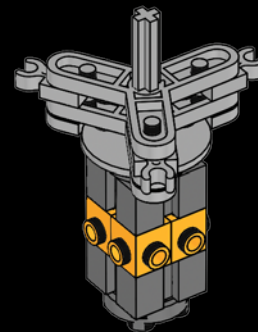

400

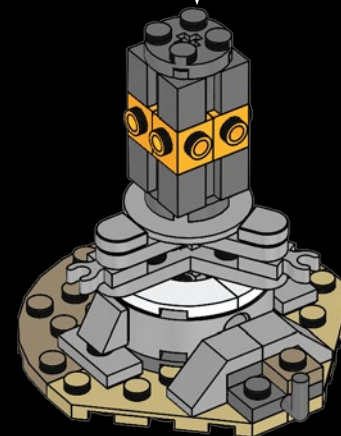



401

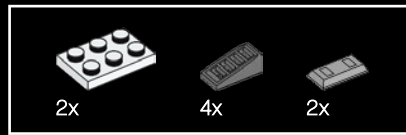
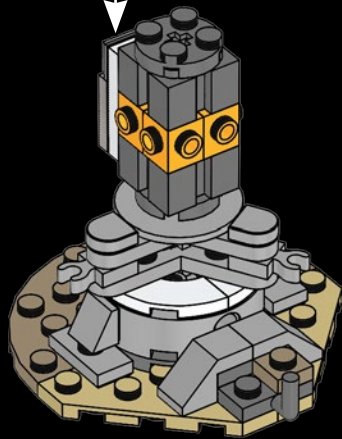
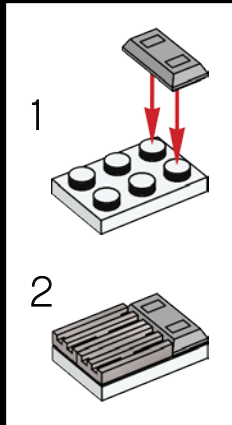

402

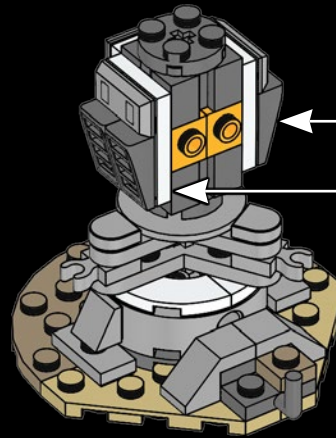
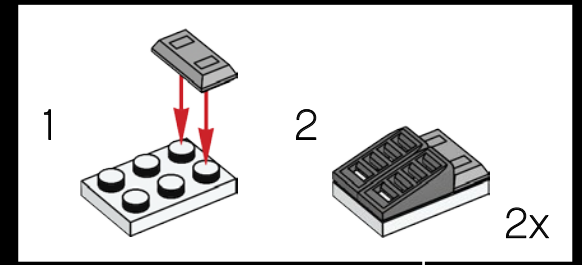

403

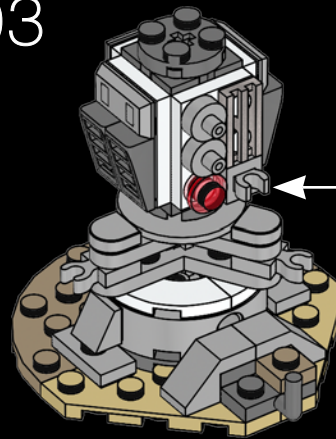
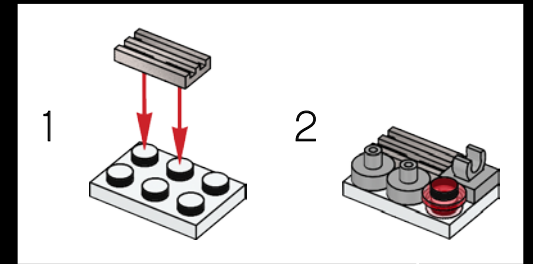

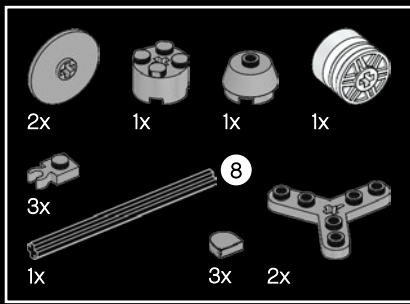

404

1



2

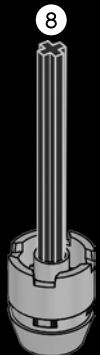

3

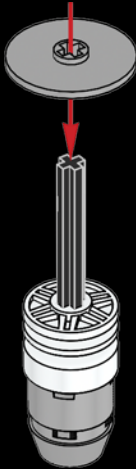

4

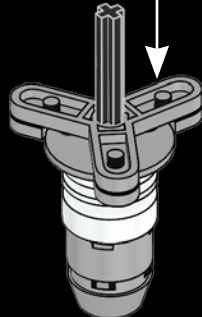
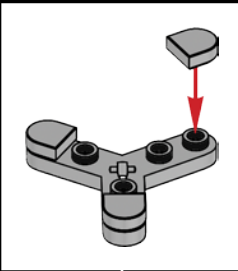

5

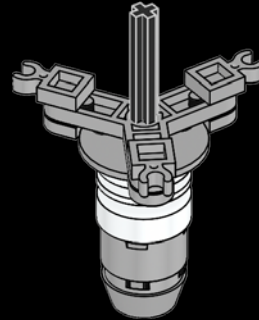

6

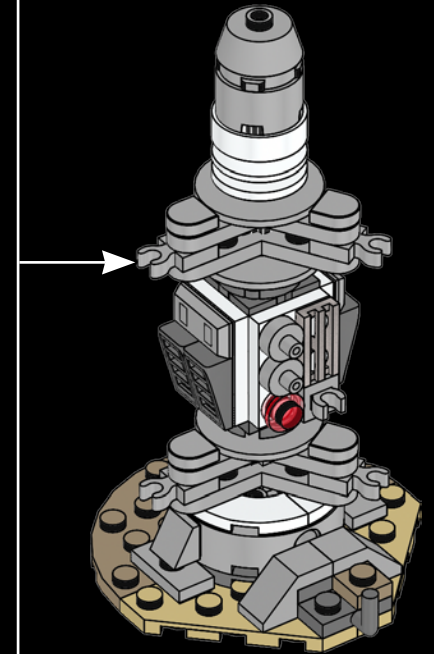
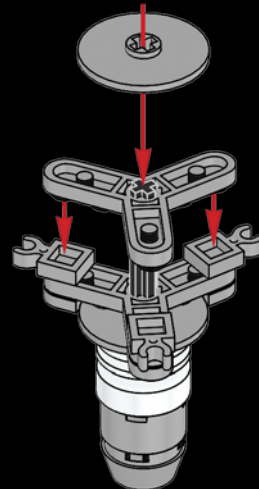

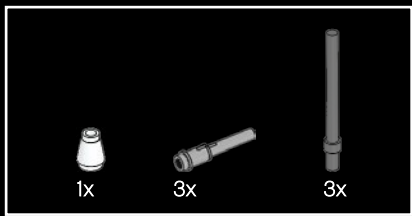

405

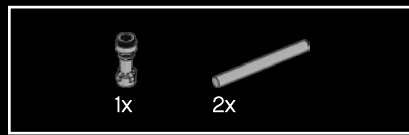
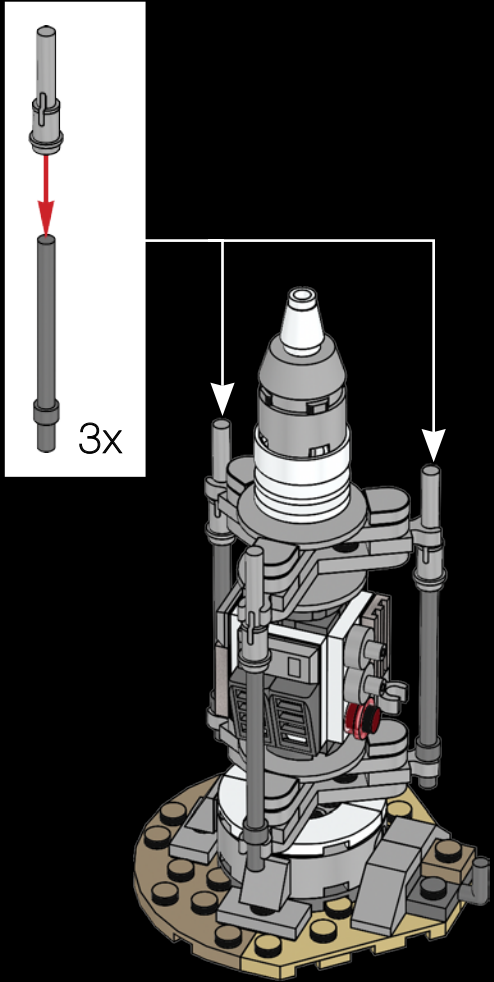

406

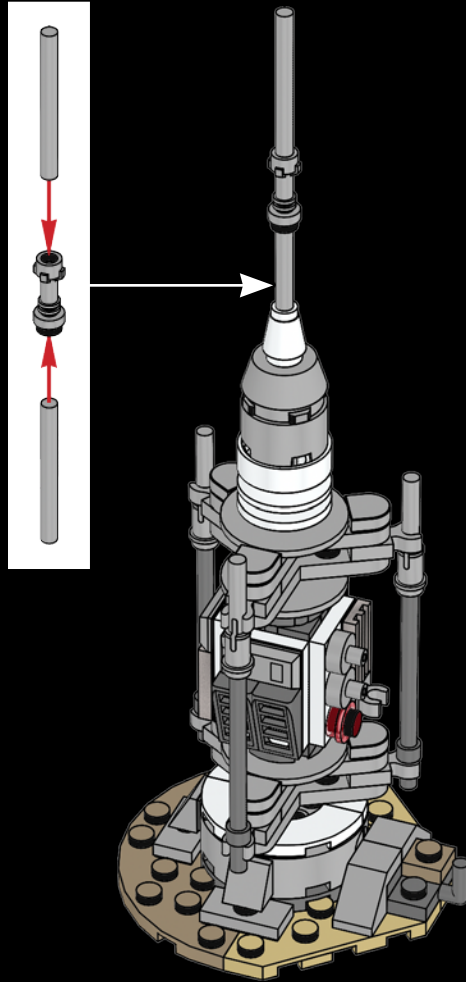

407

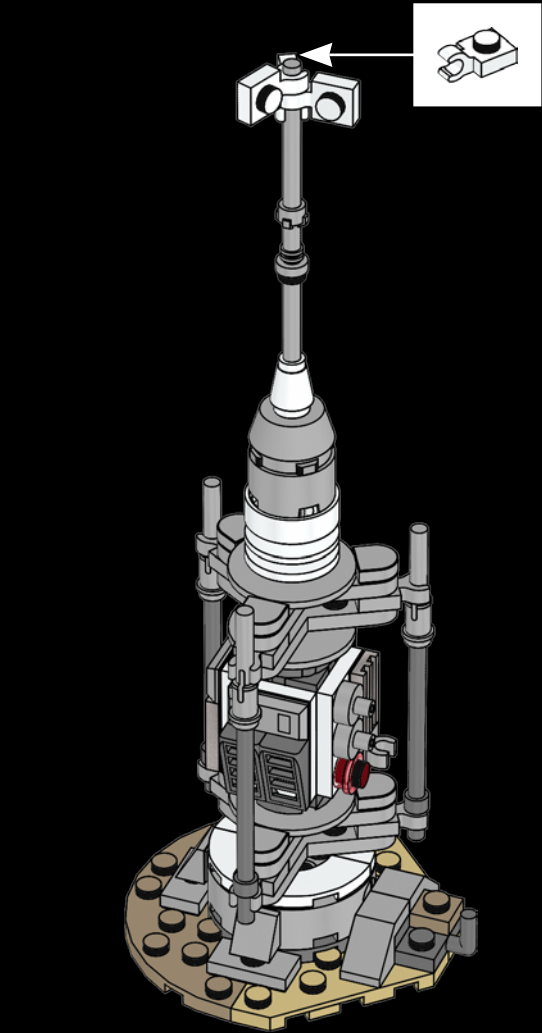

408

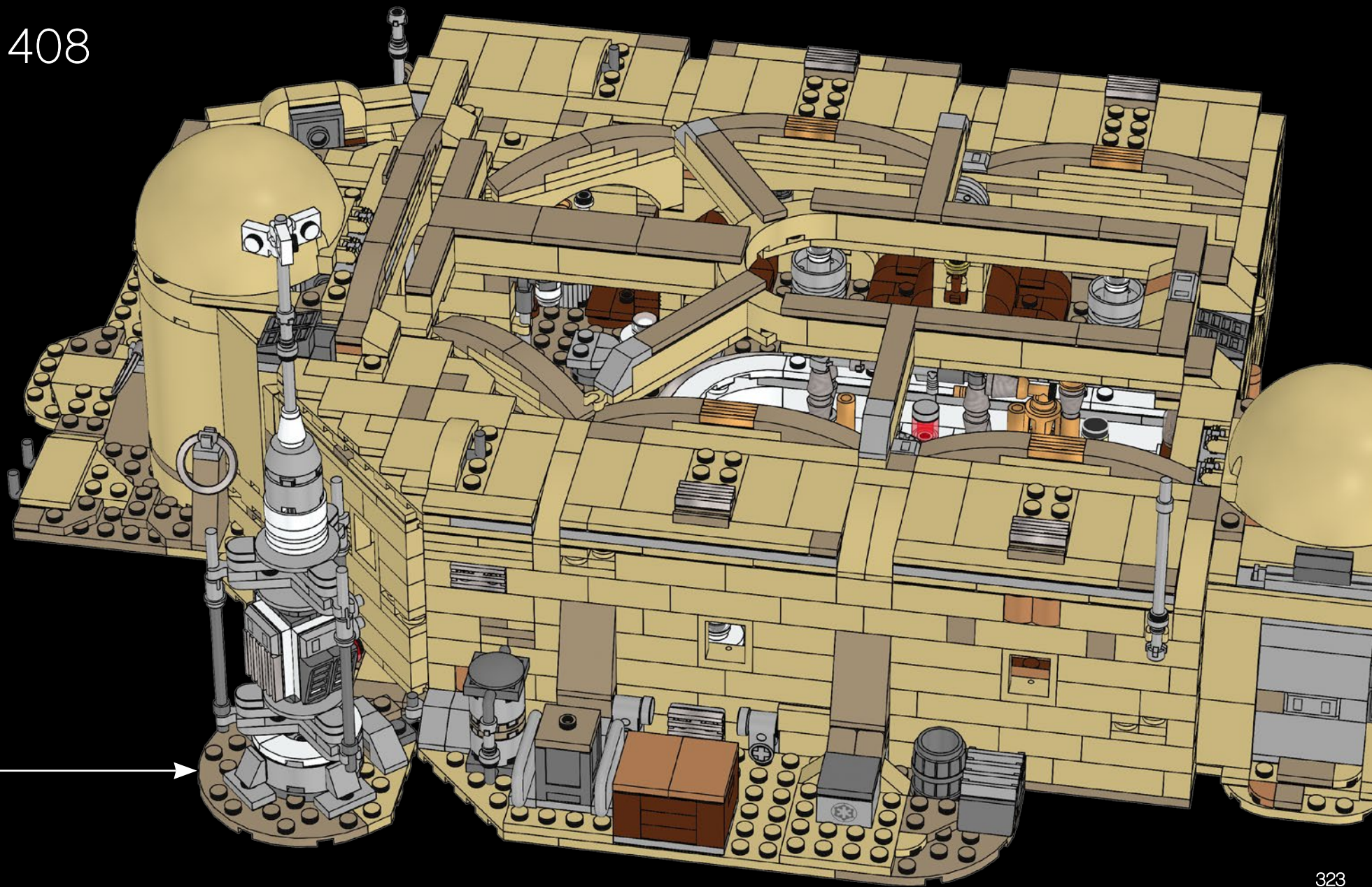

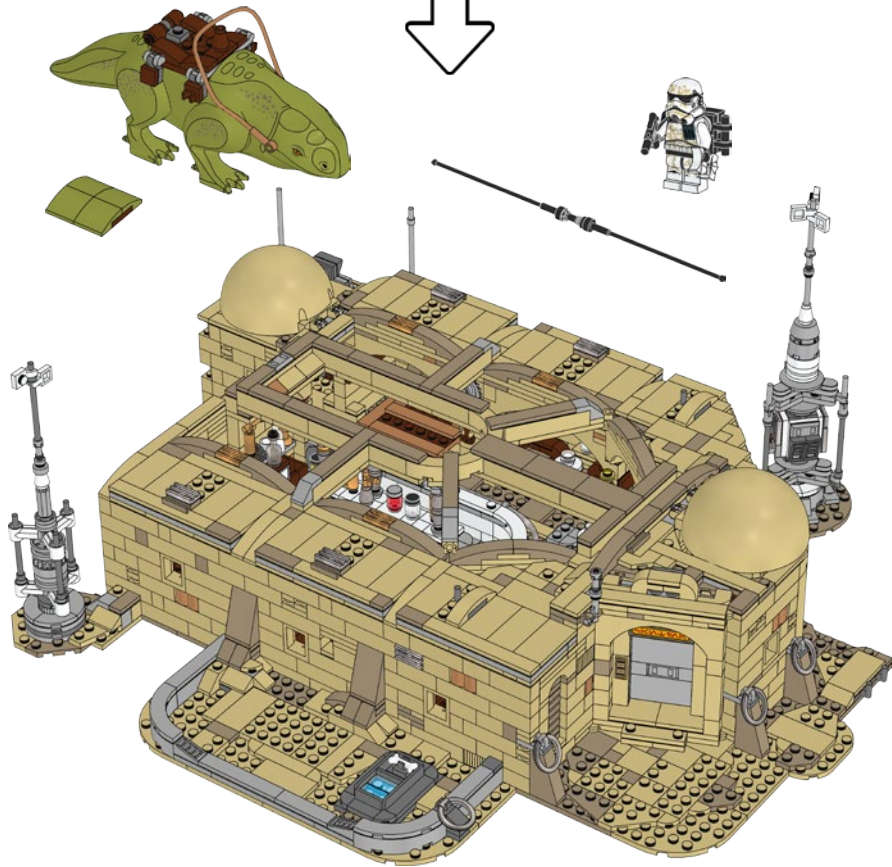
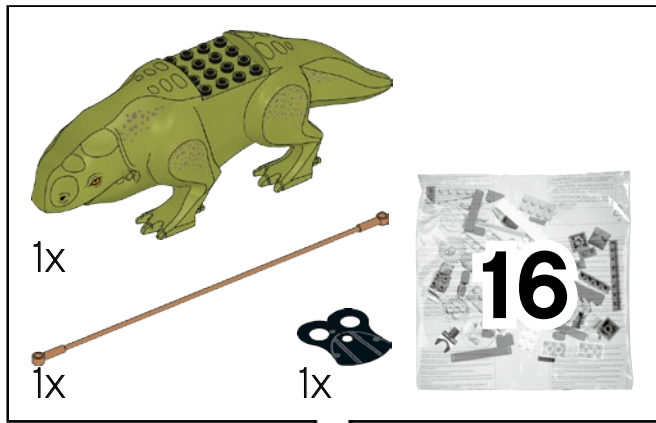

1

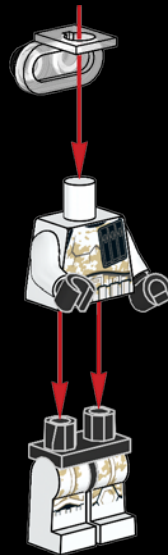

2



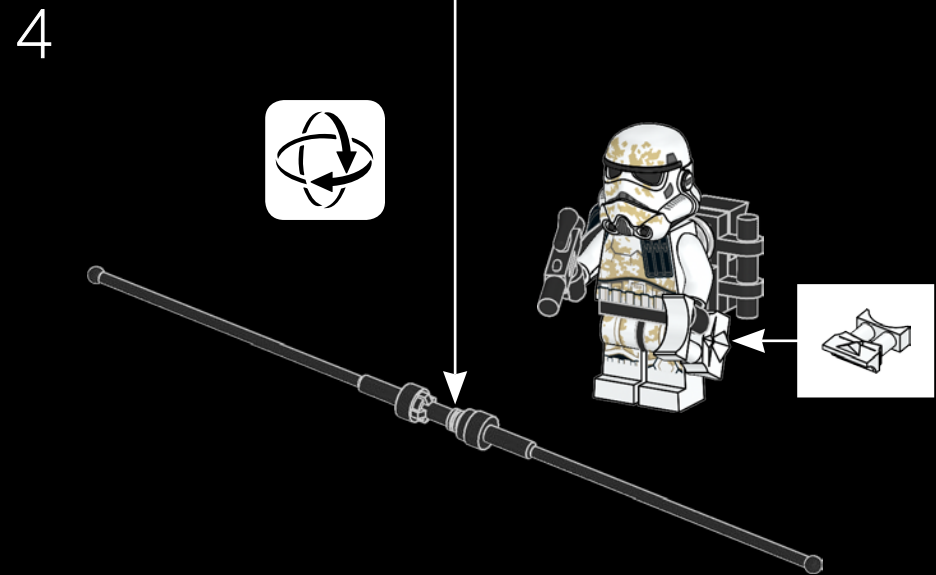
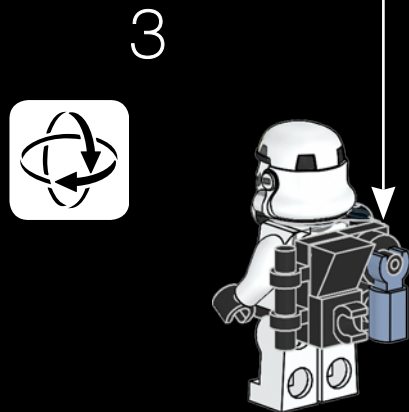
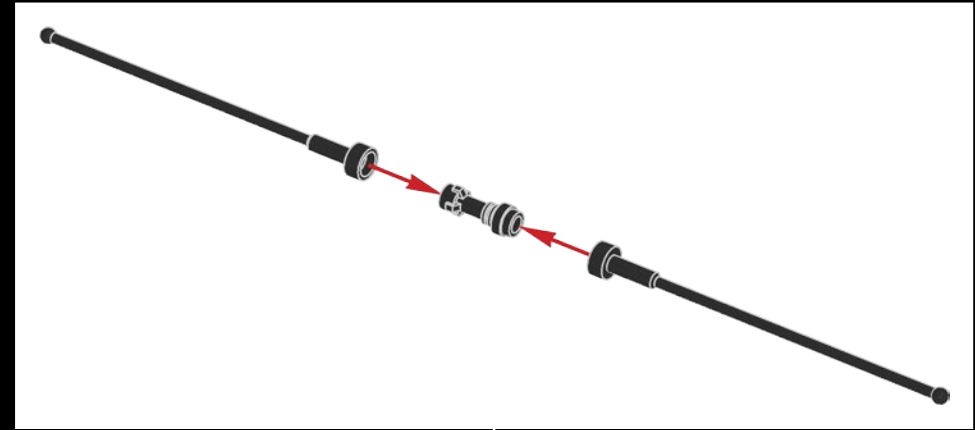
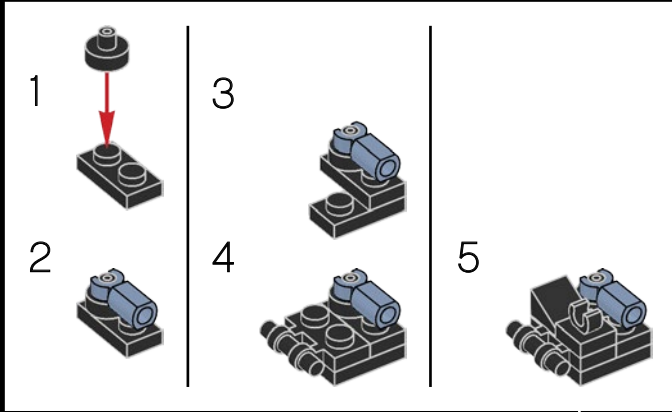

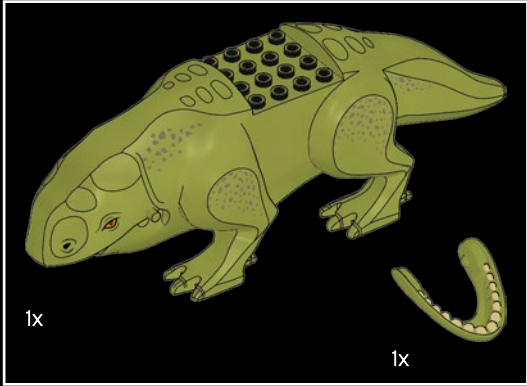
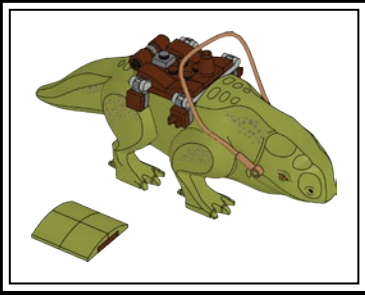

1

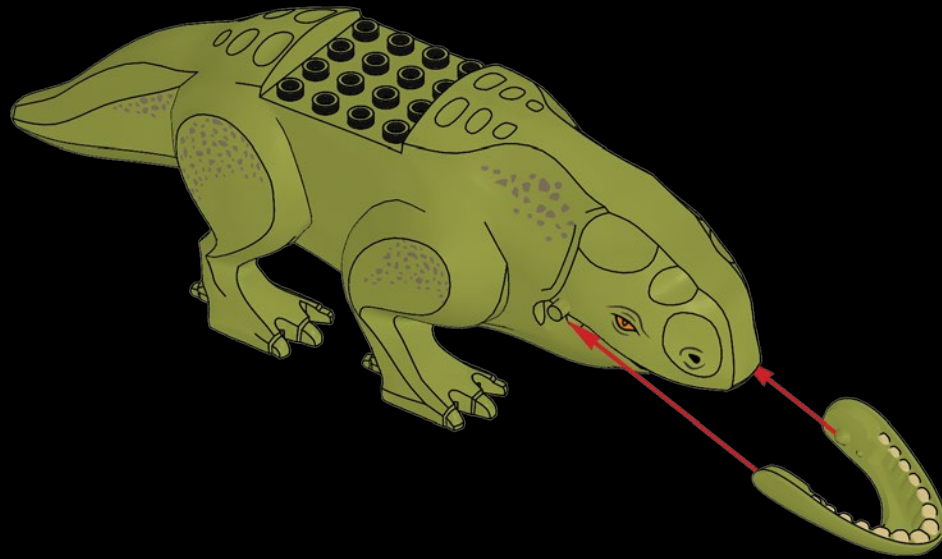

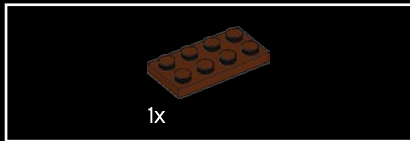
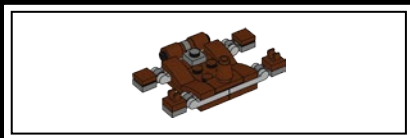

2



3



4



5

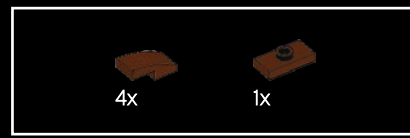
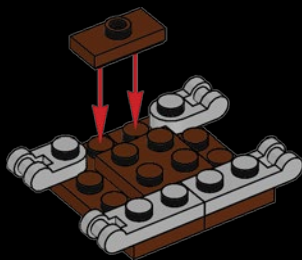

6

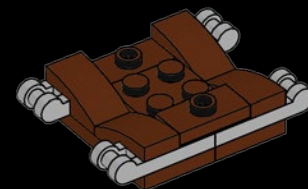

7

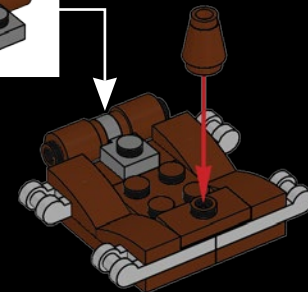



8

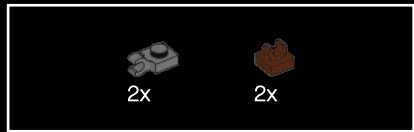
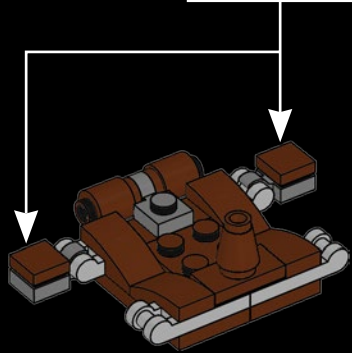
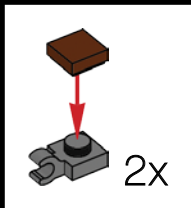

9

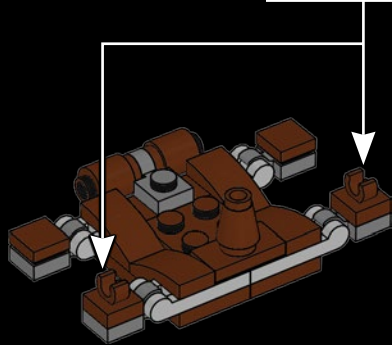
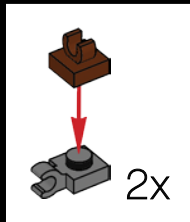

10

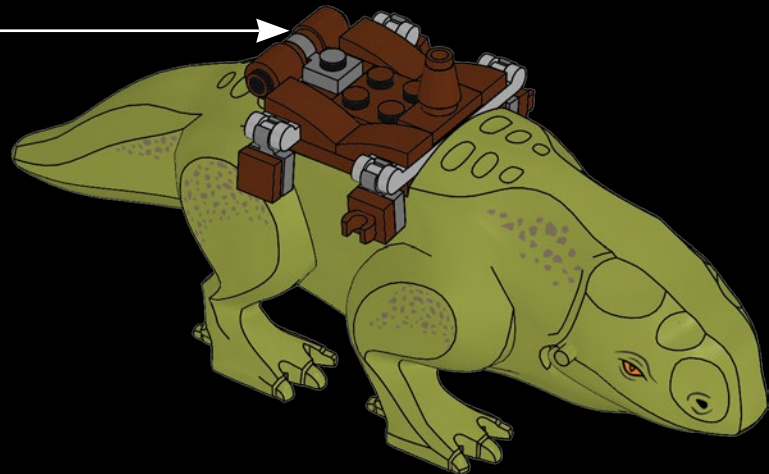

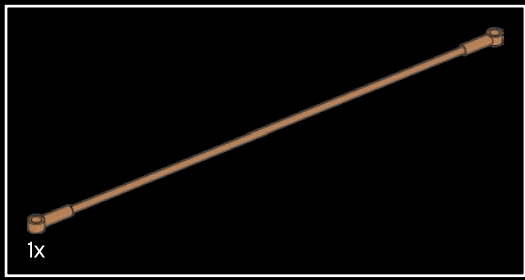

11

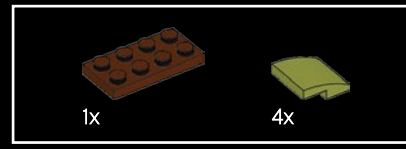
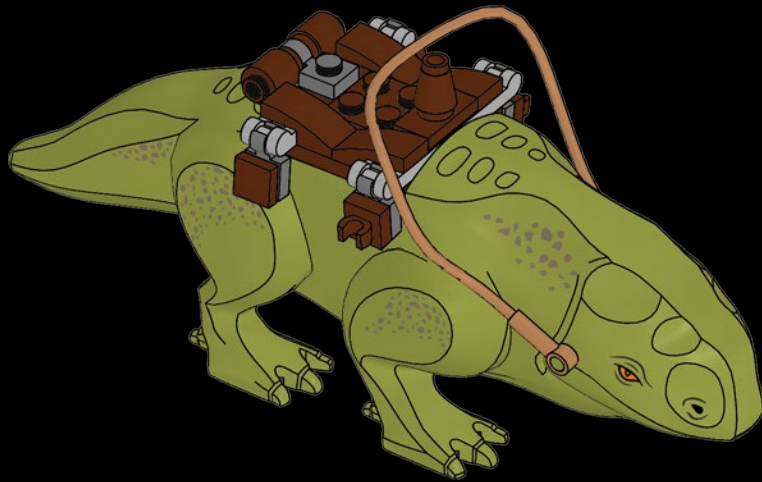

12

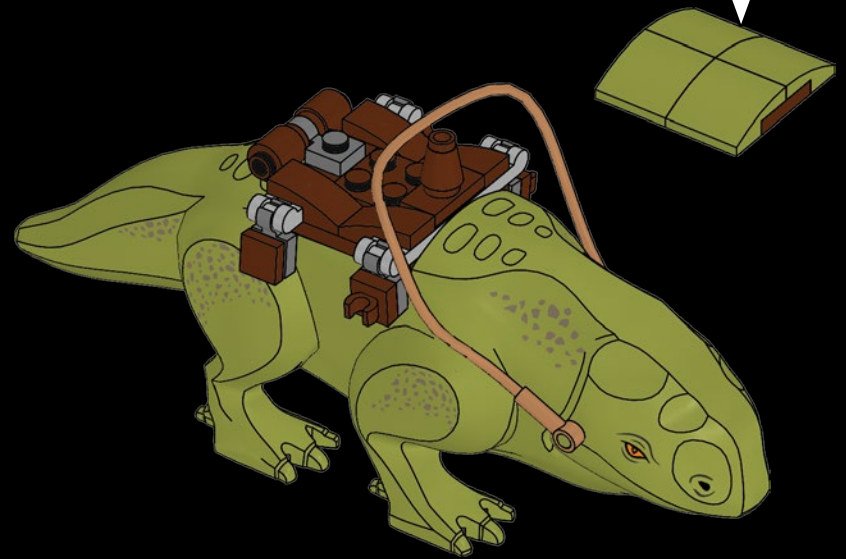
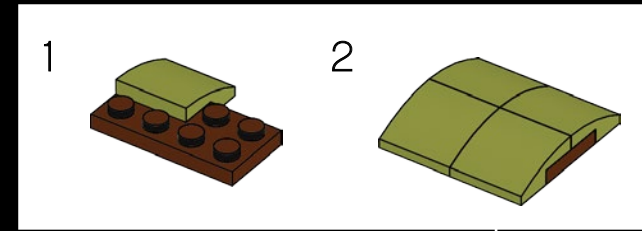

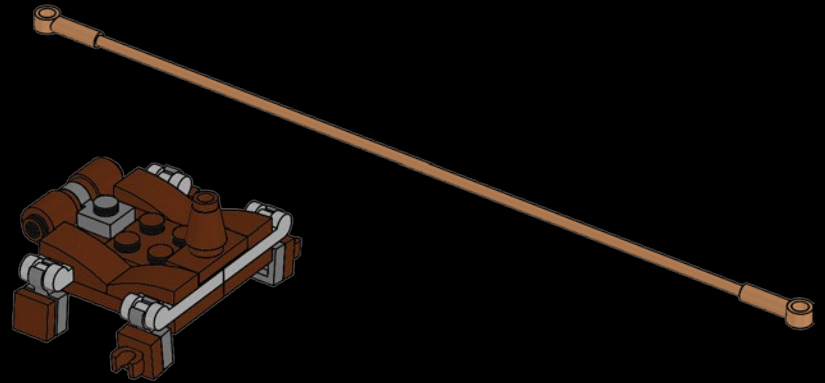
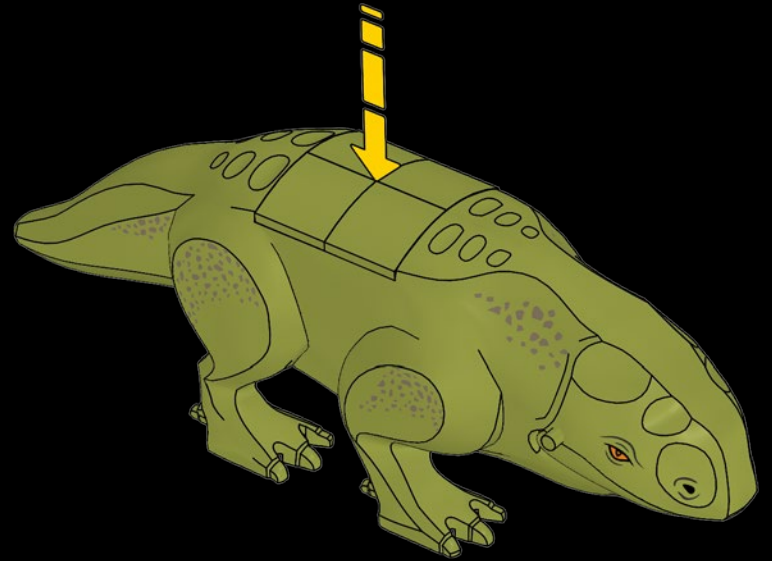
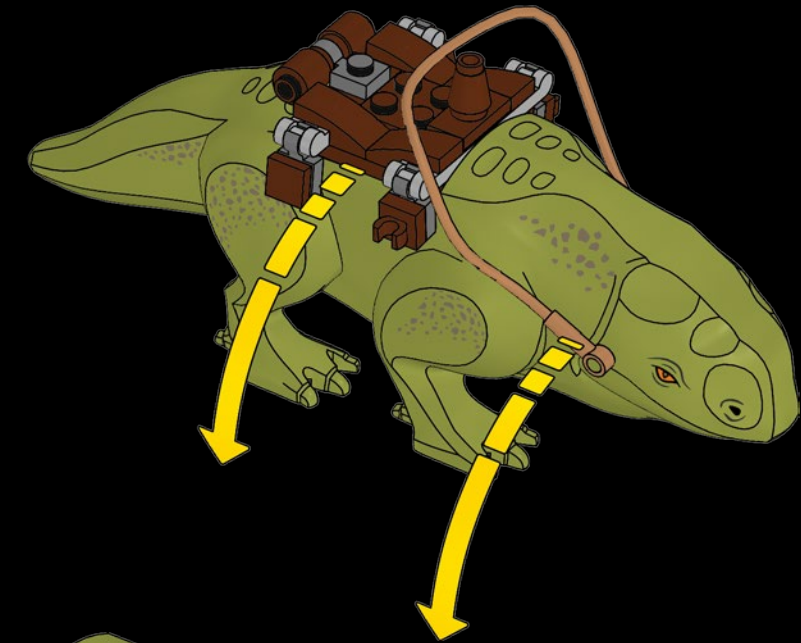

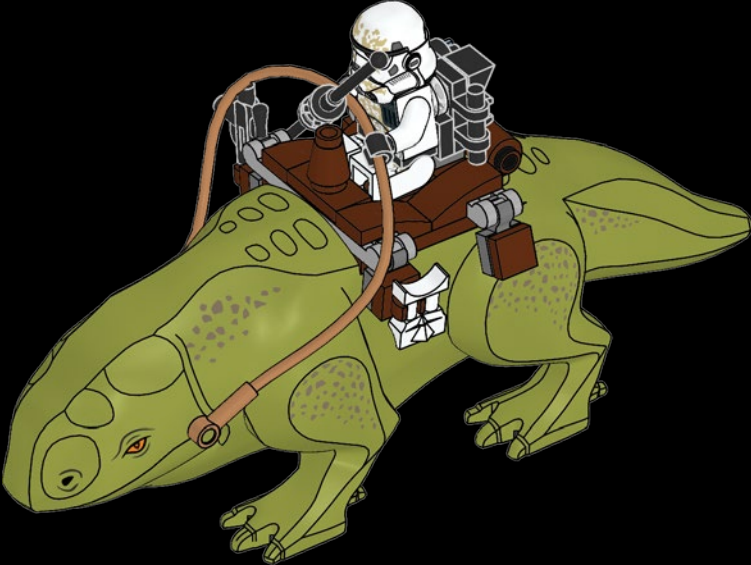

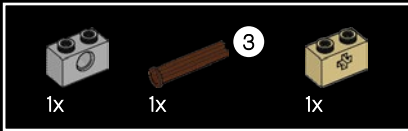
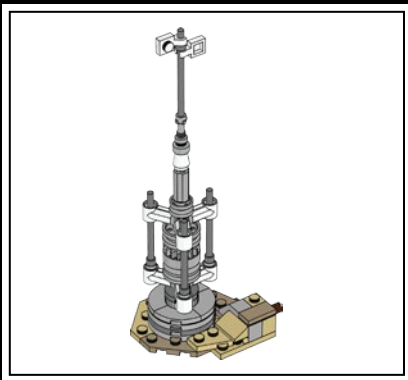

409

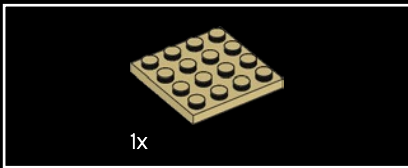
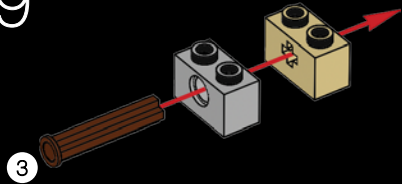

410

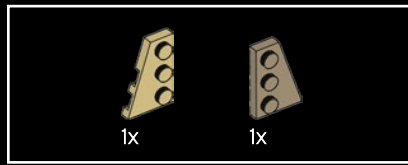
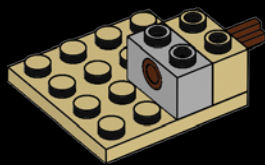

411

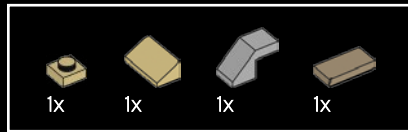
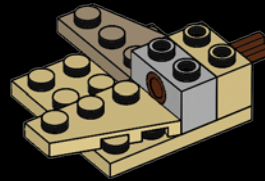

412

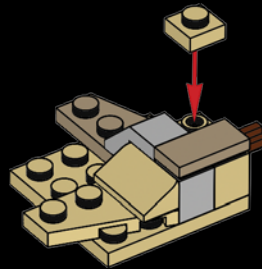

413

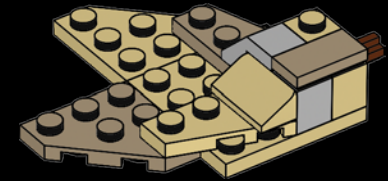

414

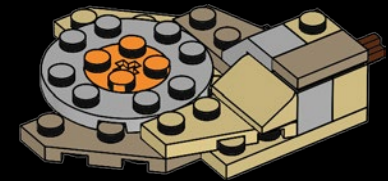

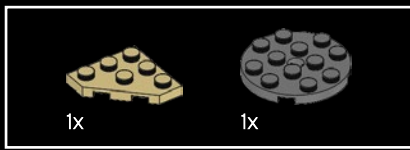

415

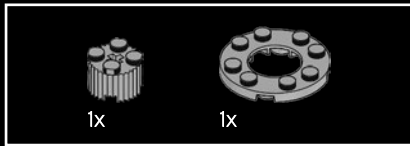
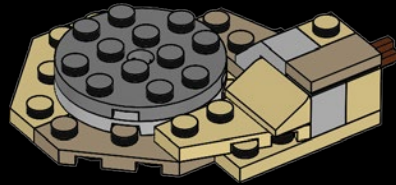

416

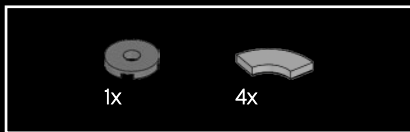
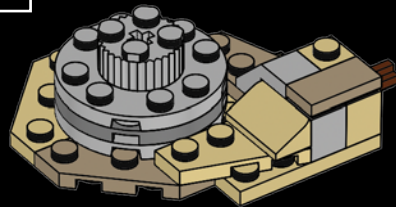

417

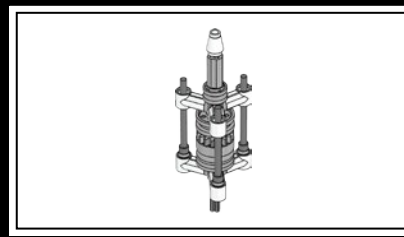
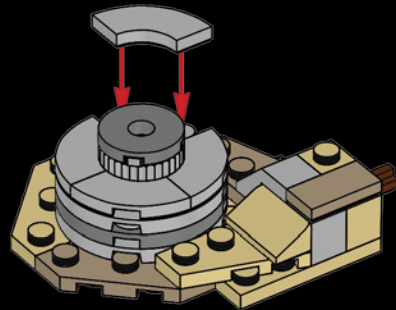

418

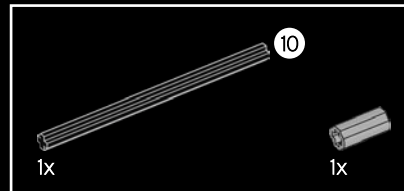
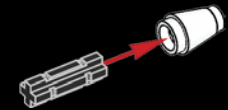
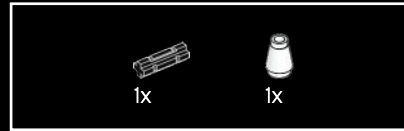

419

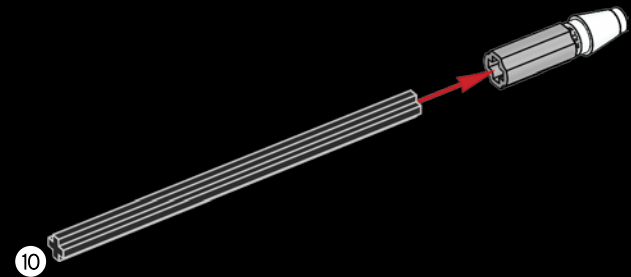

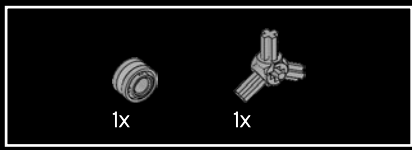

420

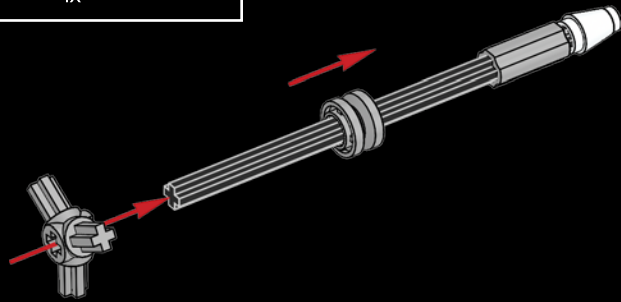

421

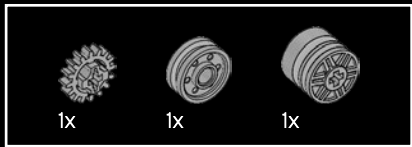
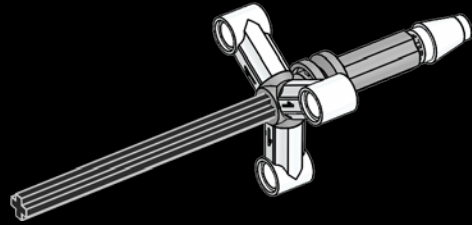

422

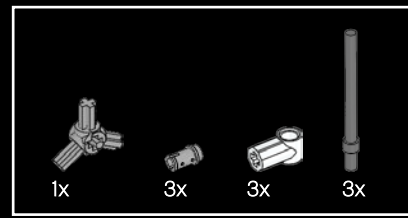
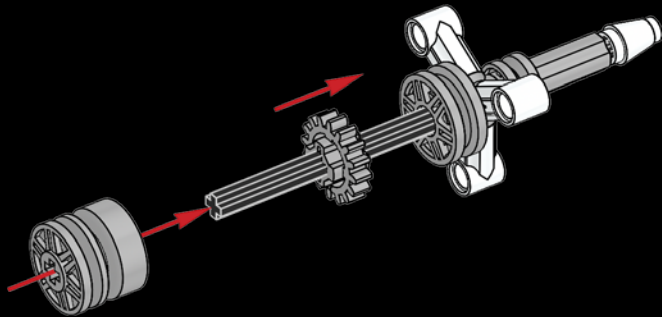

423

1



2



3

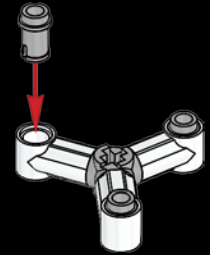

4

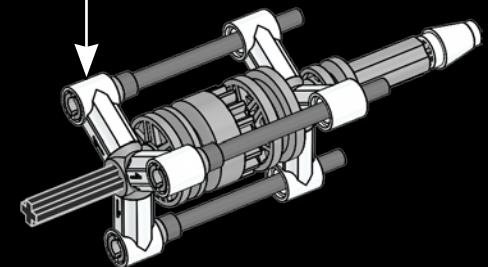
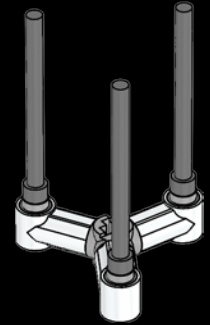

424

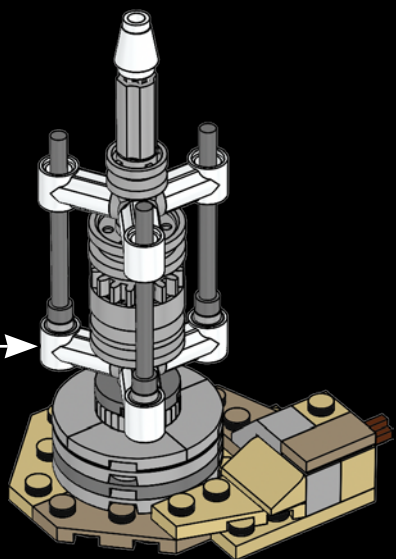

425

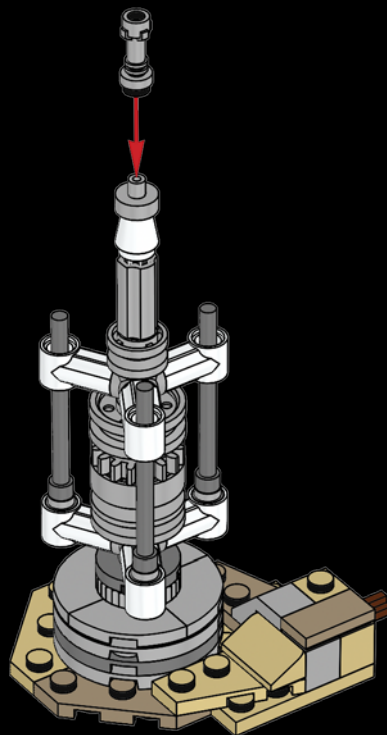
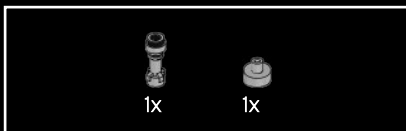

426

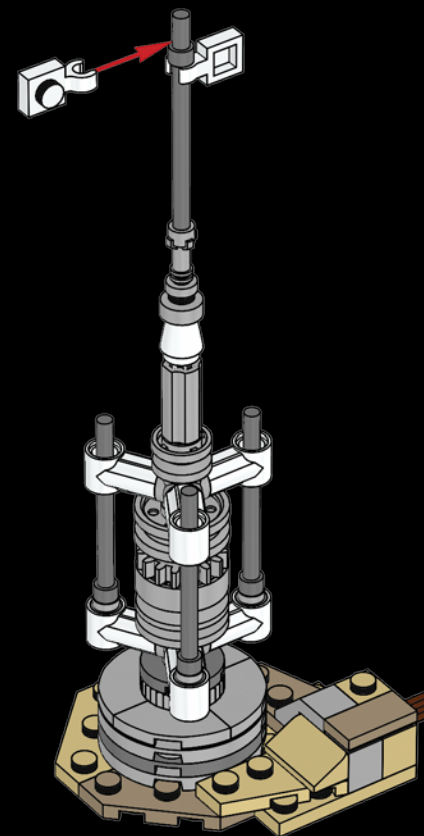
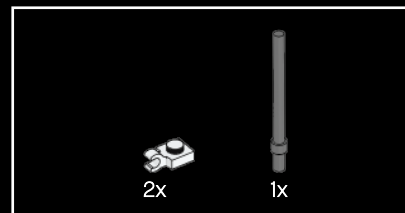

427

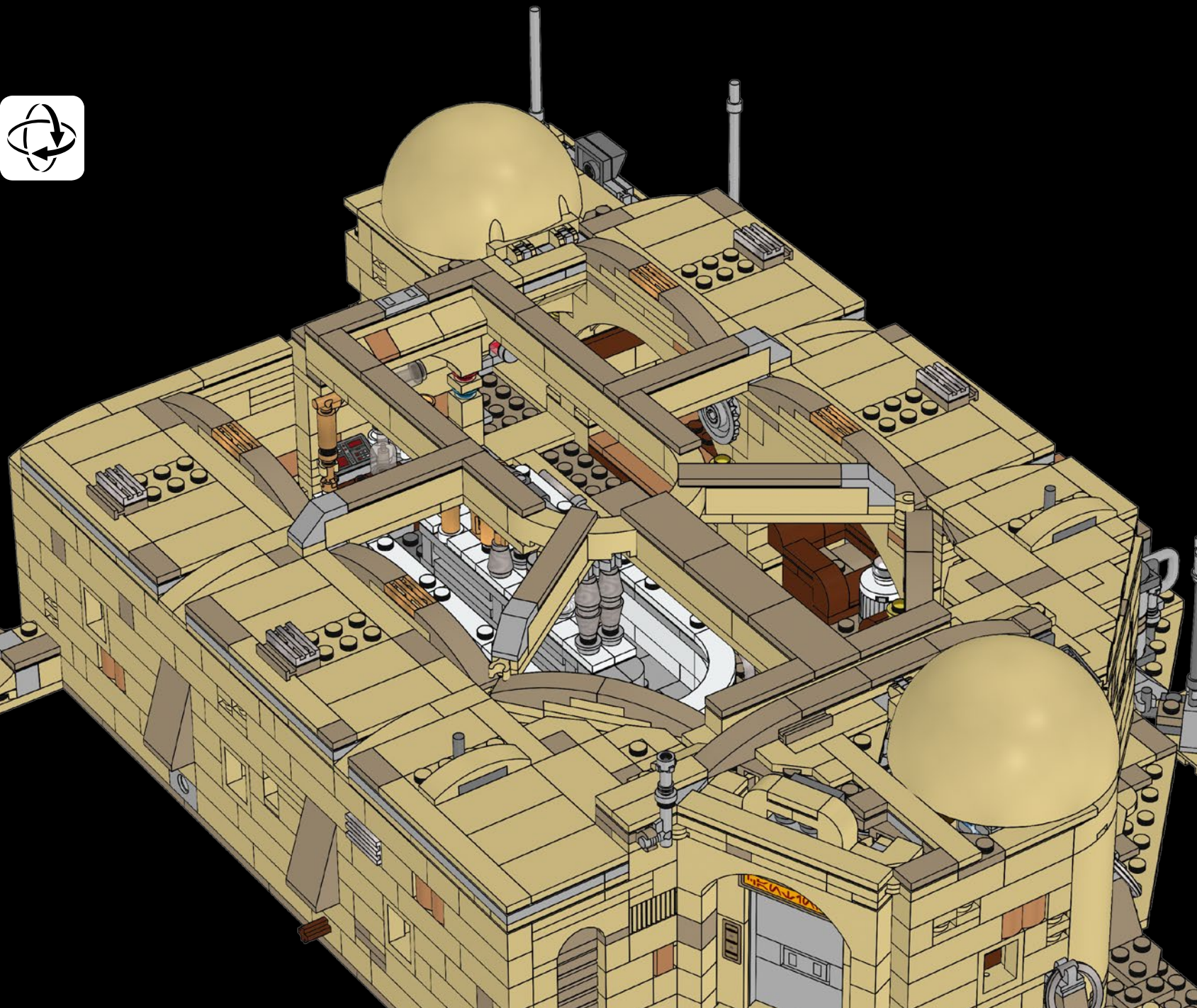
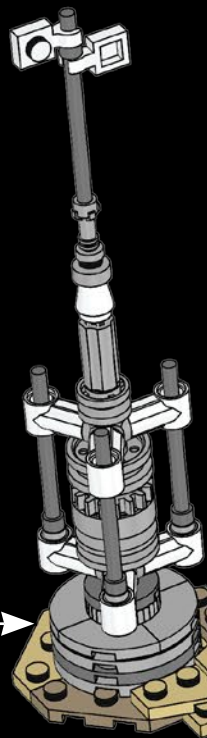

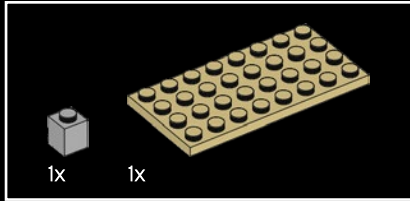
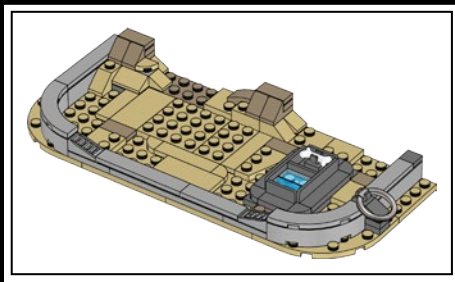

428

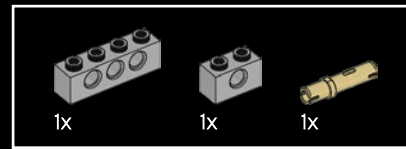
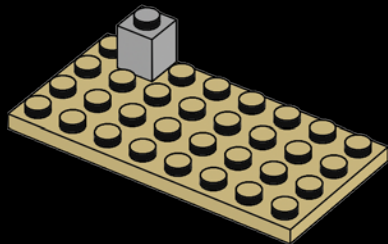

429

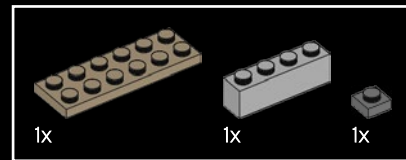
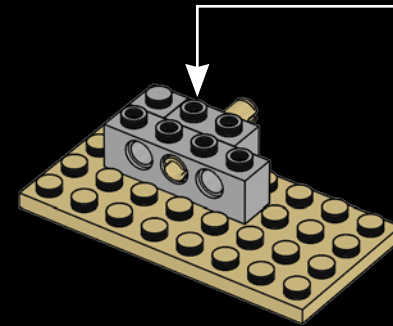

430

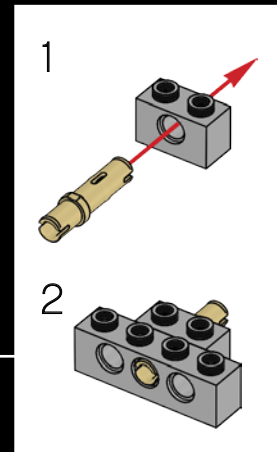
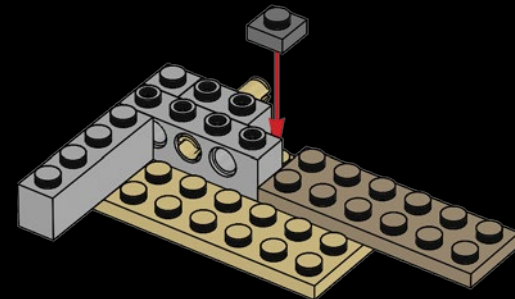

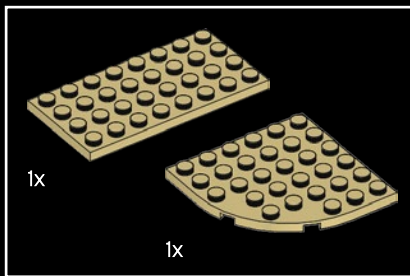

431

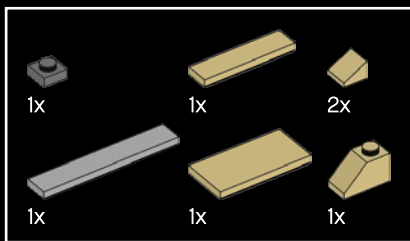
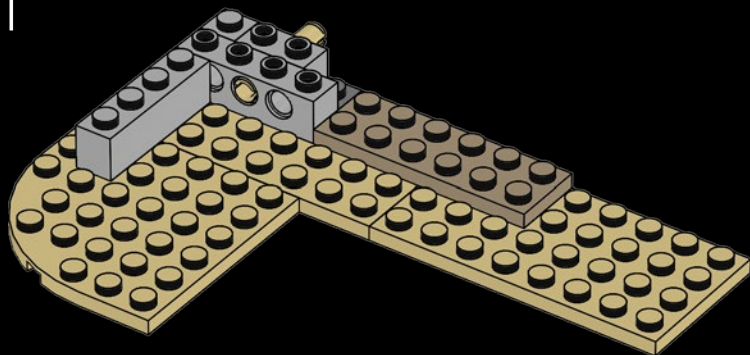

432

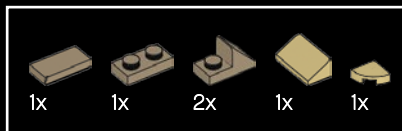
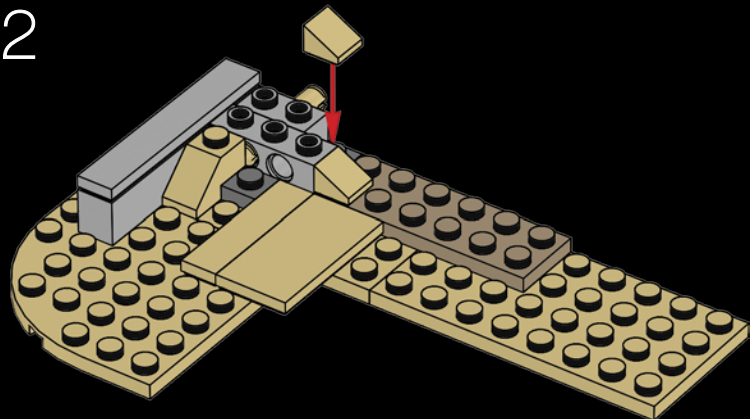

433

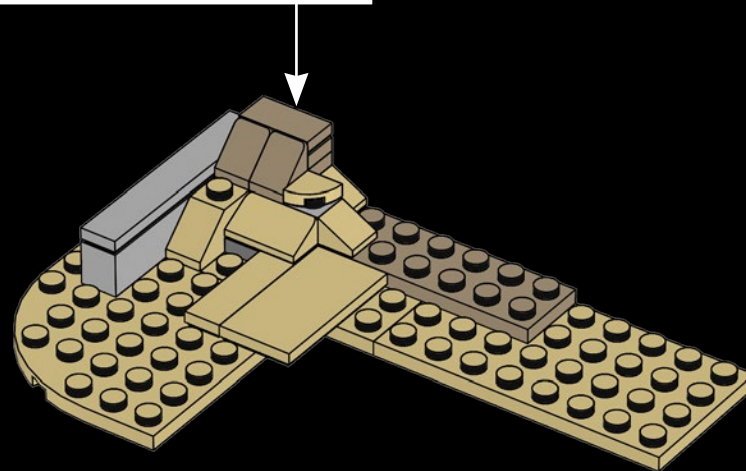
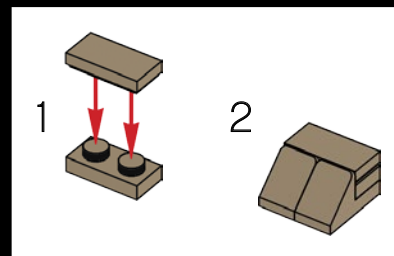

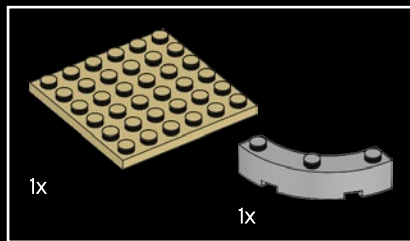

434

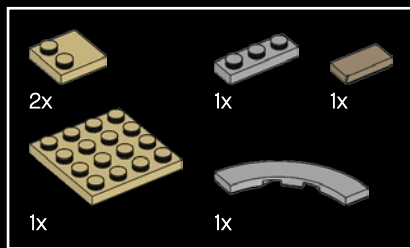
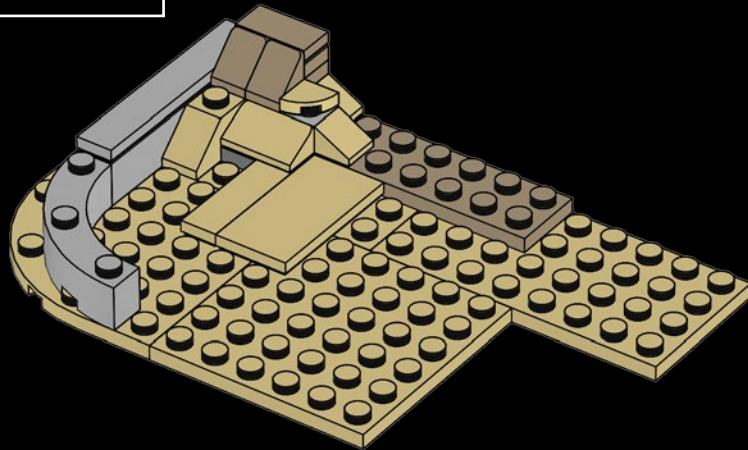

435

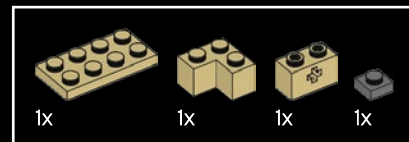
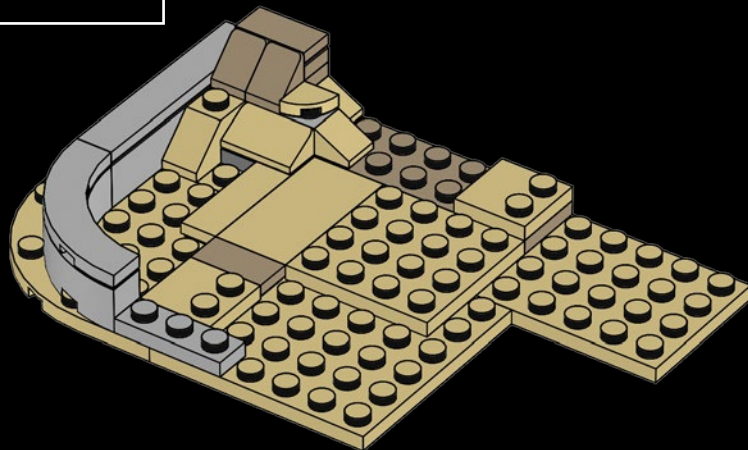

436

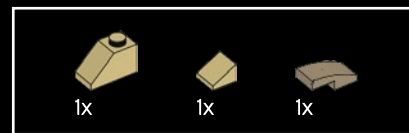
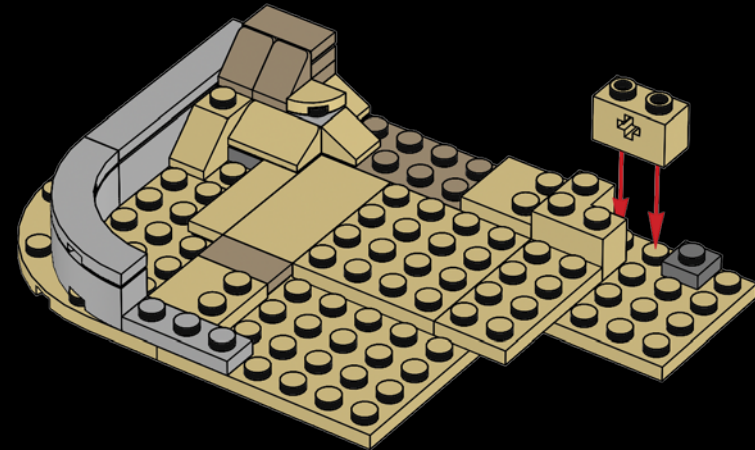

437

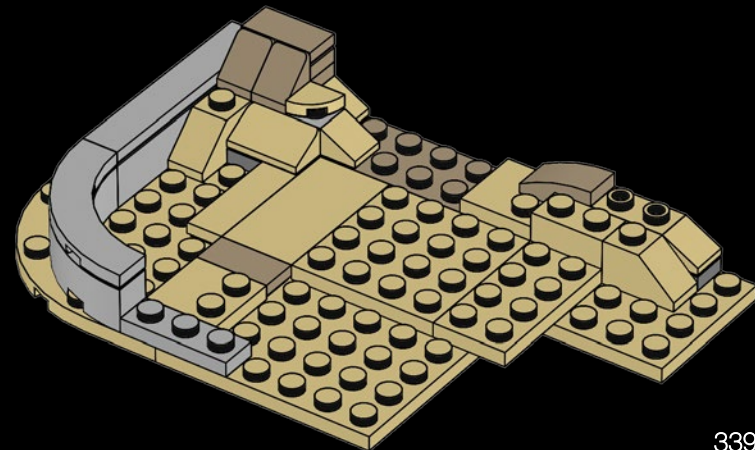

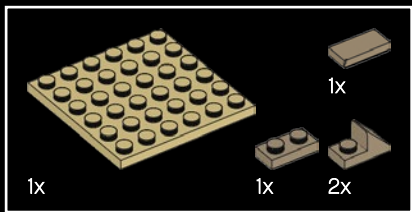

438

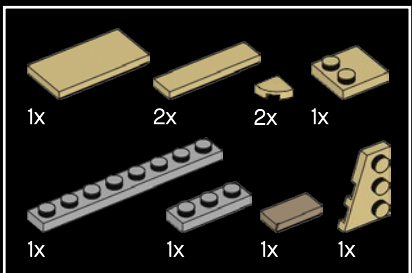
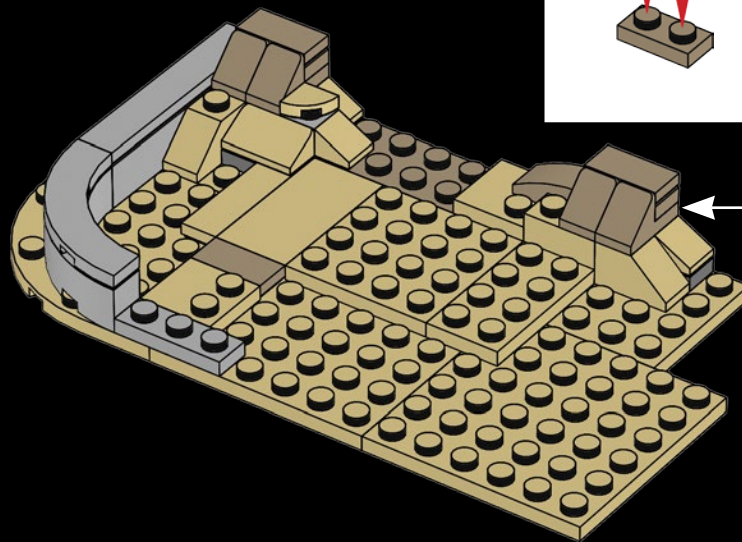
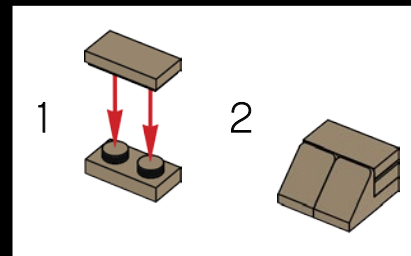

439

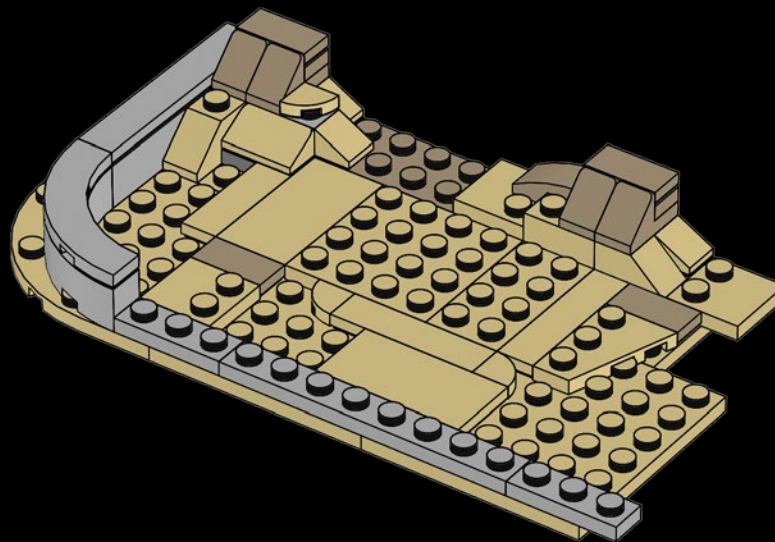

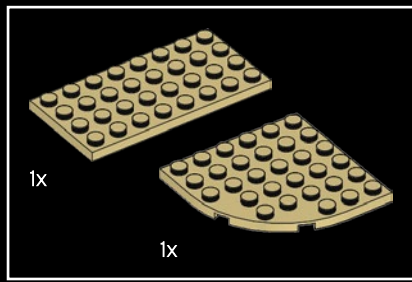

440

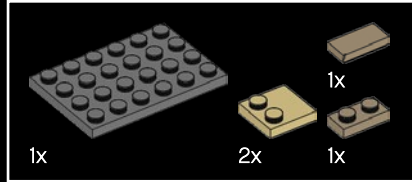
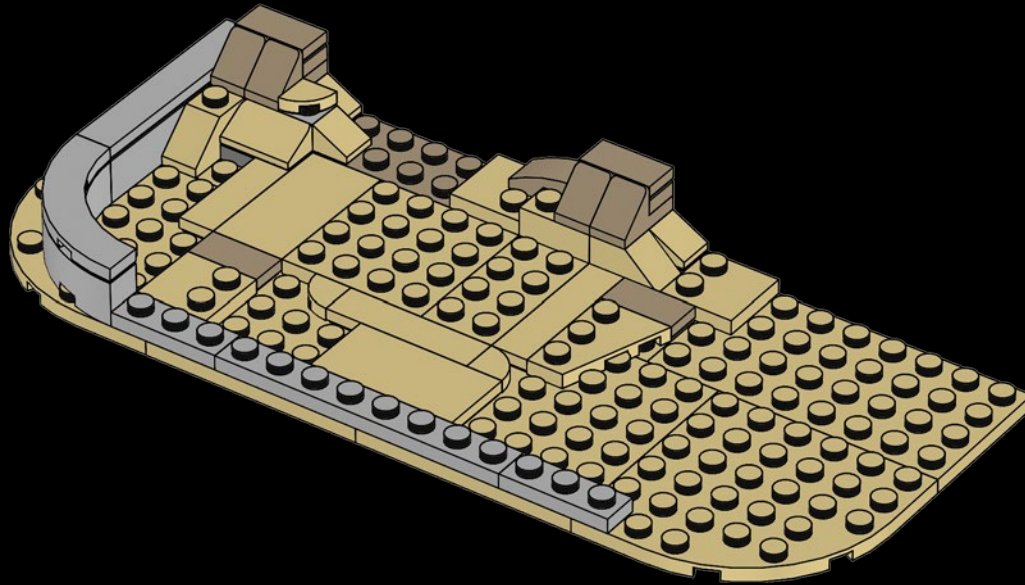

441

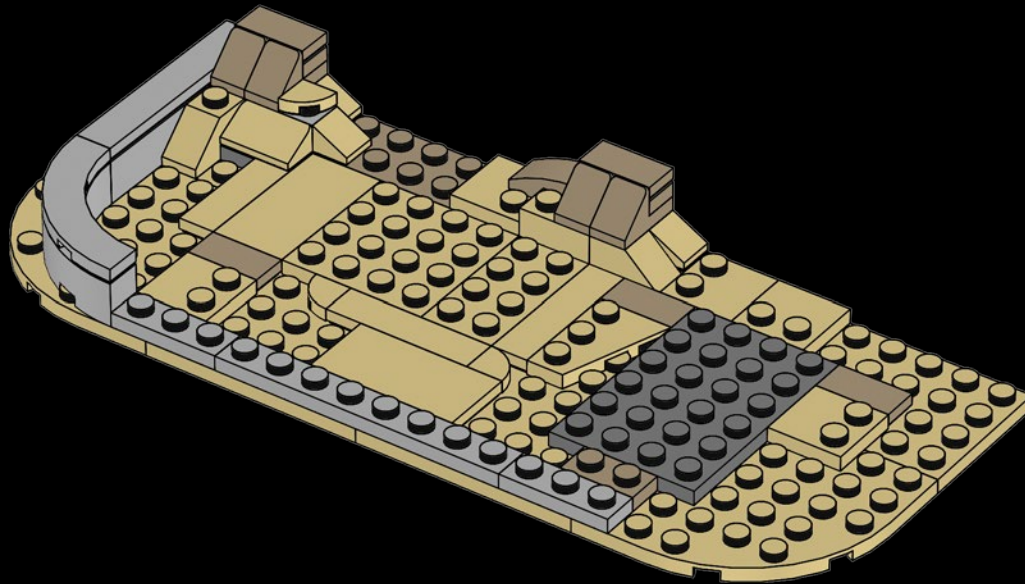

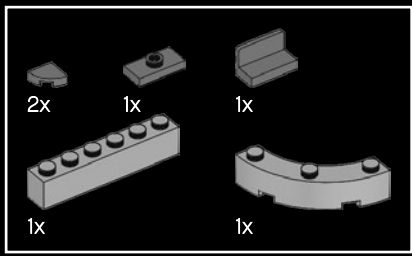

442

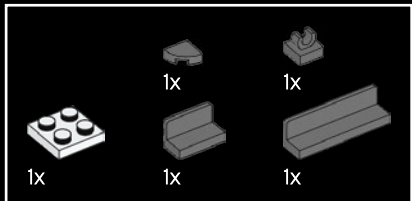
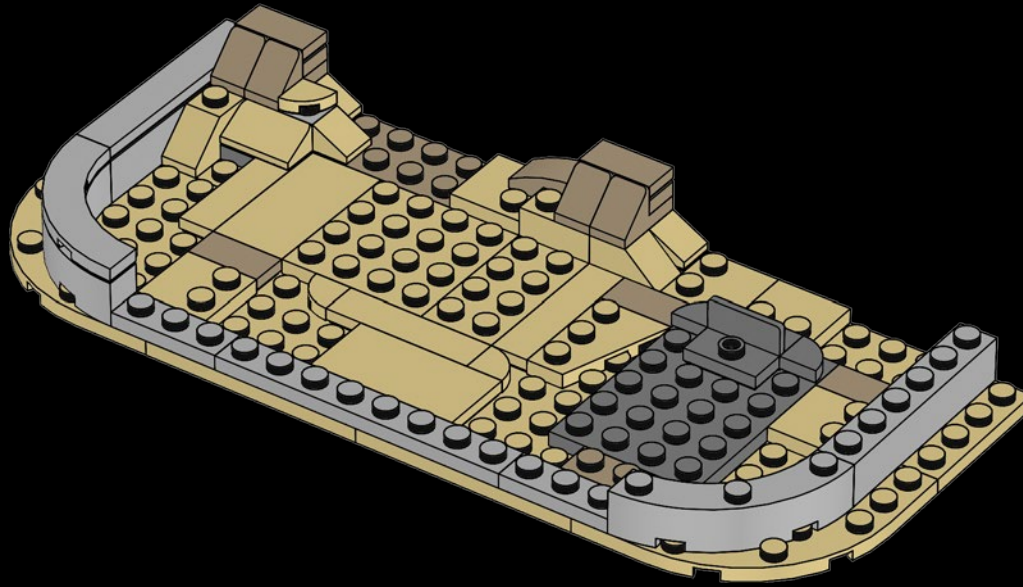

443

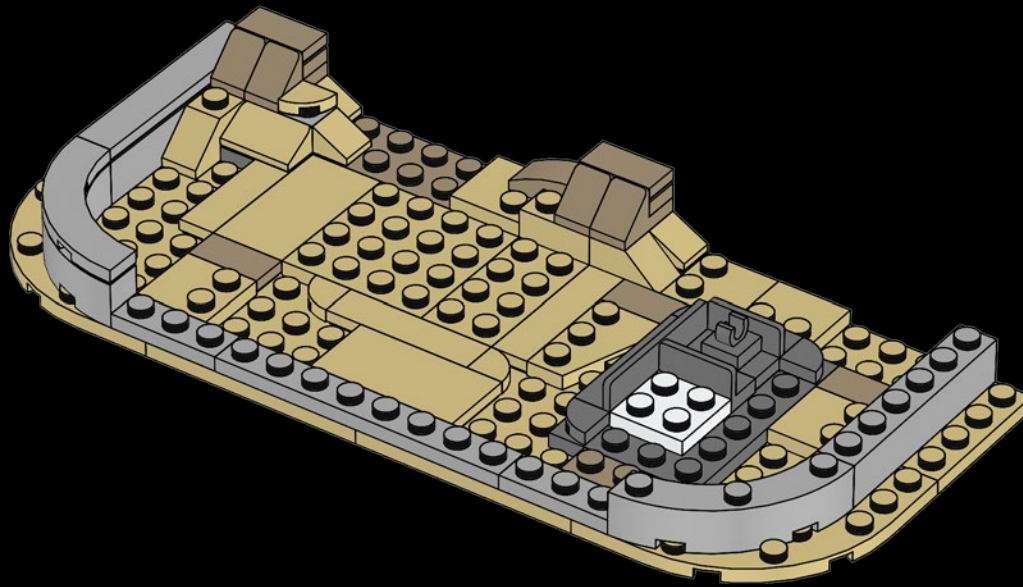

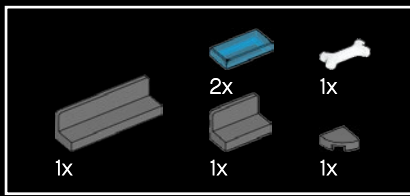

444

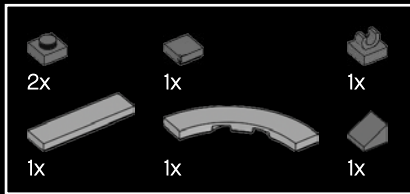
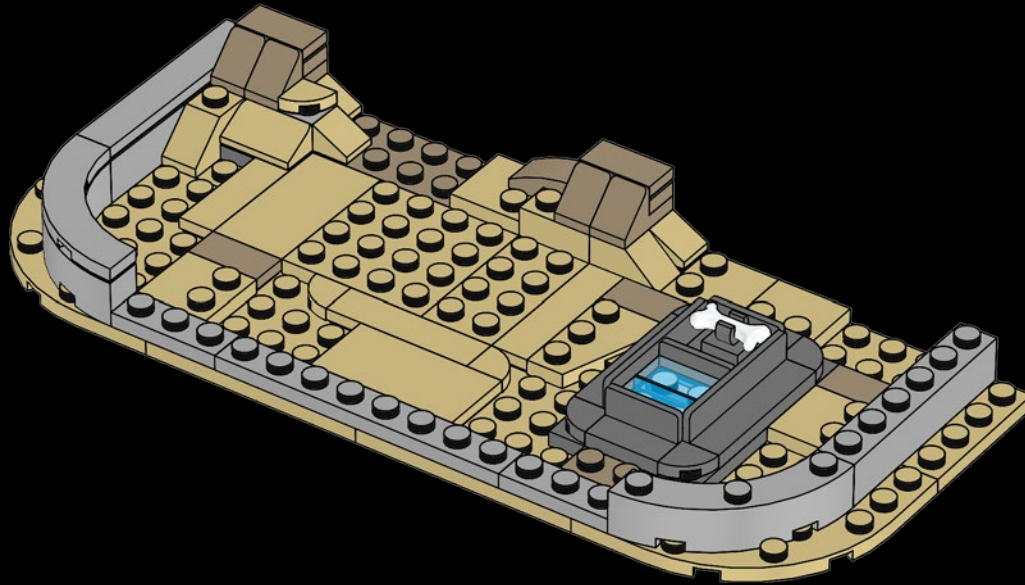

445

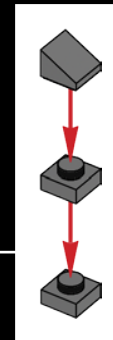
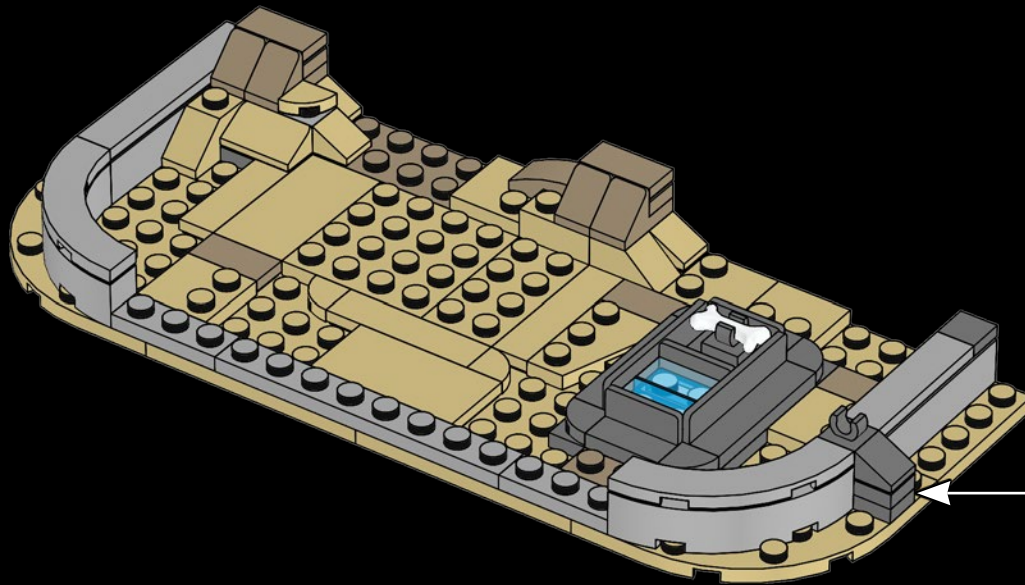

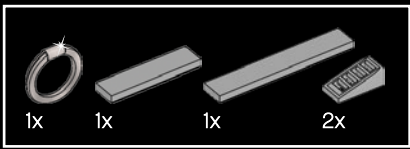

446

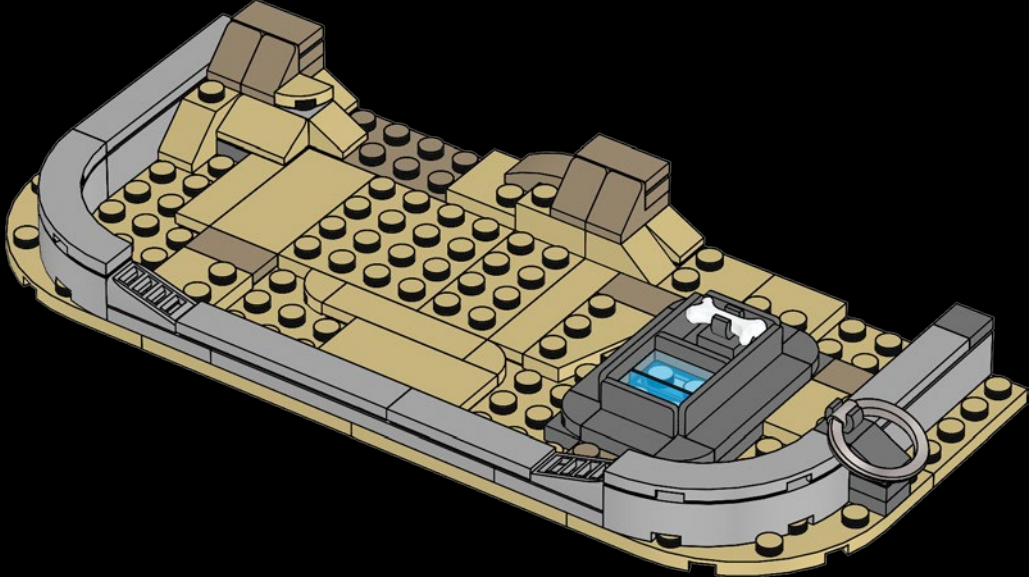

447

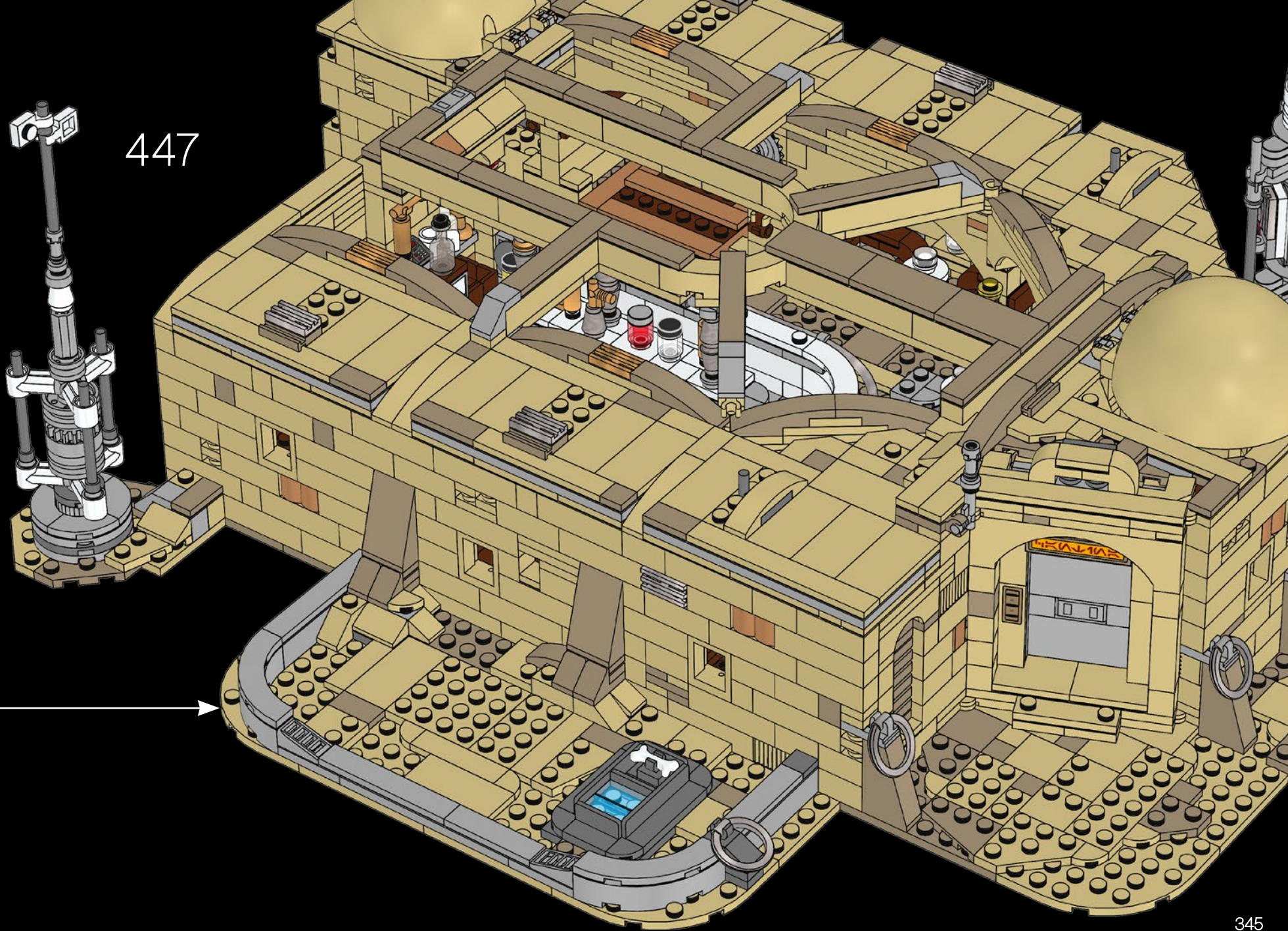

TYPICAL TATOOINE BUILDINGS

The Cantina itself is known for strong drinks, hot tunes and plenty of action. Outside the bar there's room for shady action, too. The 2 extra buildings in typical Tatooine style can connect to the Cantina building or work as standalone buildings in your own creative version of the Mos Eisley Cantina. Both buildings open and you can lift the roofs to see the details and accessories.

The 2 buildings function as a one-room house and a small junk shop operated by the Jawa minifigure. This could be where the fastest hunk of junk in the galaxy gets its spare parts from. You will find pieces of scrap metal, engines and tools for sale, and its proprietor is quick to make dubious deals with unsuspecting scoundrels passing through the Spaceport. (Maybe he plans to strip the Ubrikkian 9000 Landspeeder for parts after Greedo is shot.)

BÂTIMENTS TYPIQUES DE TATOOINE

La cantina est reconnue pour ses boissons fortes, sa musique entraînante et son effervescence. L'extérieur du bar connaît aussi son lot de magouilles. Les 2 bâtiments additionnels typiques de Tatooine peuvent se connecter à la cantina, ou servir de bâtiments autonomes dans votre propre version de la cantina de Mos Eisley. Chaque bâtiment s'ouvre et vous pouvez soulever le toit pour voir les détails et les accessoires à l'intérieur.



© & ™ Lucasfilm Ltd.

Les 2 bâtiments servent de maison d'une pièce et de petite brocante exploitée par la figurine de Jawa. C'est peut-être de là que proviennent les pièces de rechange du tas de ferraille le plus rapide de la galaxie. Le magasin vend des morceaux de ferraille, des moteurs et des outils, et son propriétaire n'hésite pas à faire des transactions douteuses avec des scélérats crédules qui transitent par l'astroport. (Peut-être prévoit-il dépouiller le landspeeder Ubrikkian 9000 de ses pièces après que Greedo ait été abattu.)

ARQUITECTURA TÍPICA DE TATOOINE

La cantina es conocida por sus bebidas fuertes, su moderna música y su incesante acción. Fuera del bar también hay espacio para asuntos de dudosa legalidad.

Los 2 edificios complementarios presentan el típico estilo de Tatooine y se pueden conectar al modelo de la cantina o ubicarse en posiciones independientes, dándote la oportunidad de crear tu propia versión creativa de la Cantina de Mos Eisley. Además, se abren y cuentan con techo removible para ver los detalles y accesorios que contienen.

Uno de ellos representa una casa de una habitación, mientras que el otro es una pequeña tienda de chatarra administrada por la minifigura del Jawa. Tal vez sea de aquí de donde saca sus refacciones el pedazo de chatarra más rápido de la galaxia. El establecimiento vende pedazos de metal de desecho, motores y herramientas, y su propietario no duda en hacer tratos cuestionables con alguno que otro rufián desprevenido que pase por el puerto espacial. (Tal vez planea desarmar el landspeeder Ubrikkian 9000 para venderlo por partes una vez que Greedo deje de estar allí para impedirlo.)



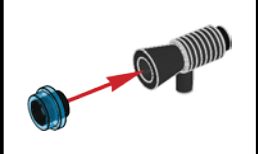
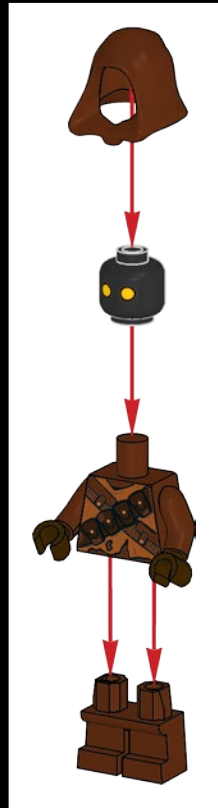
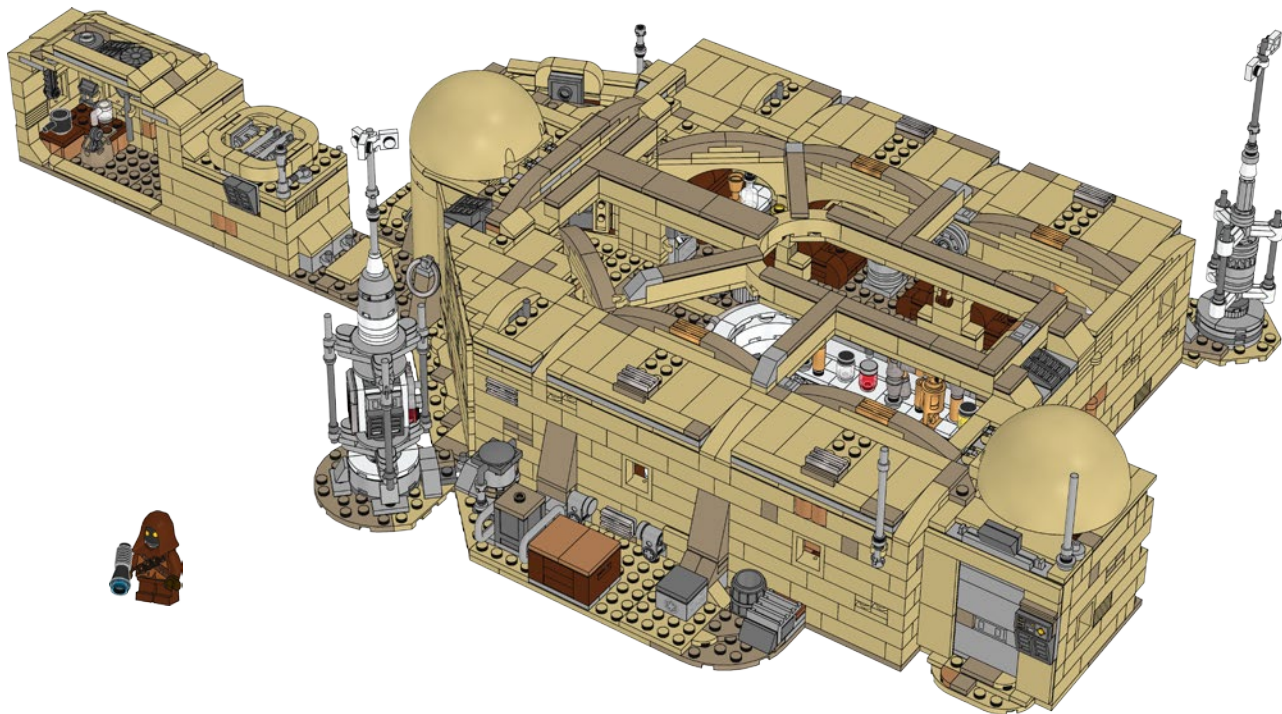
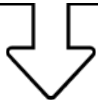

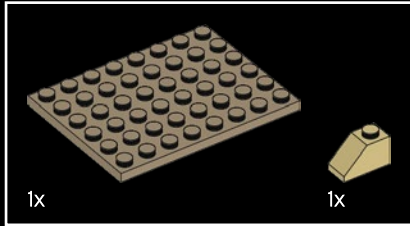
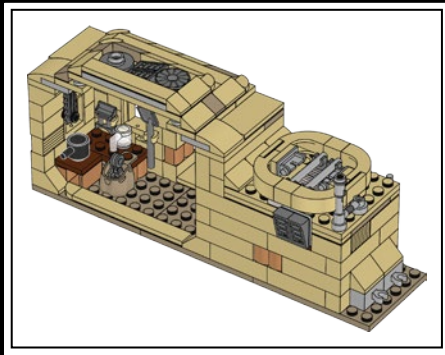

448

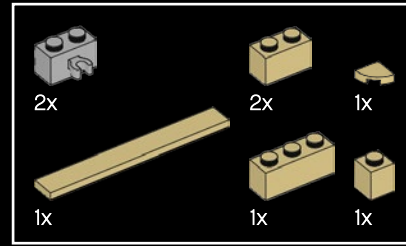
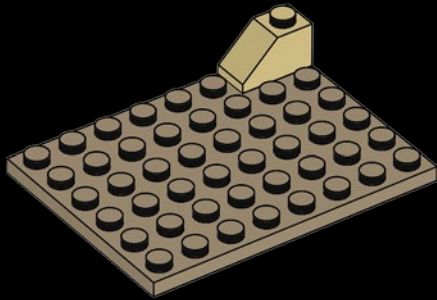

449

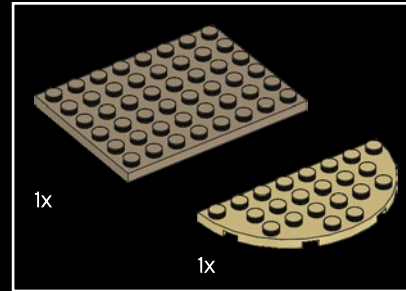
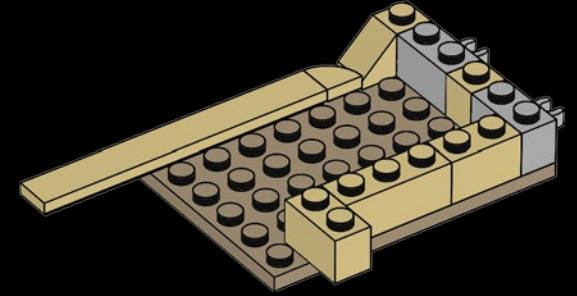

450

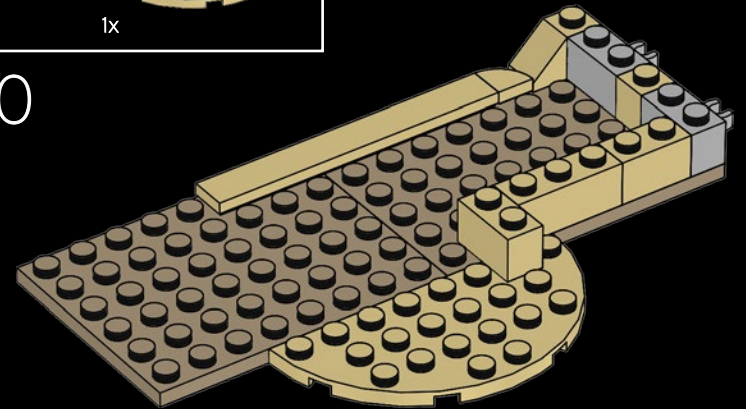

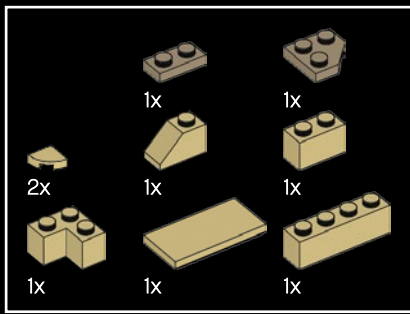

451

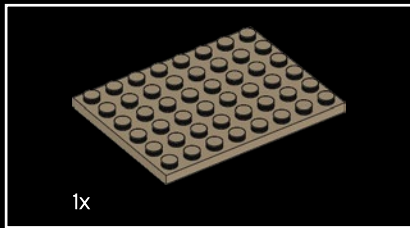
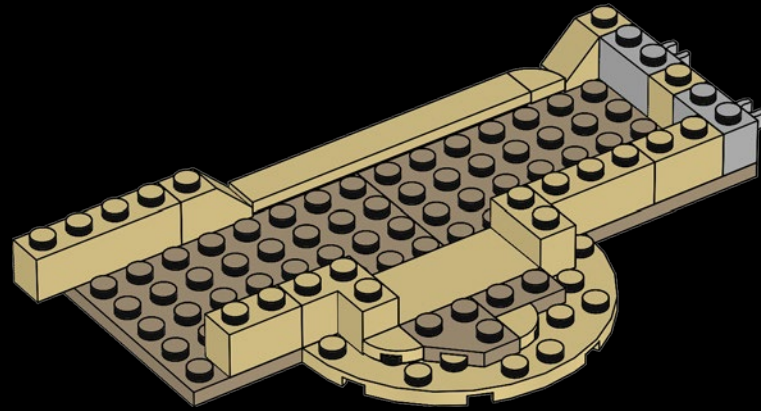

452

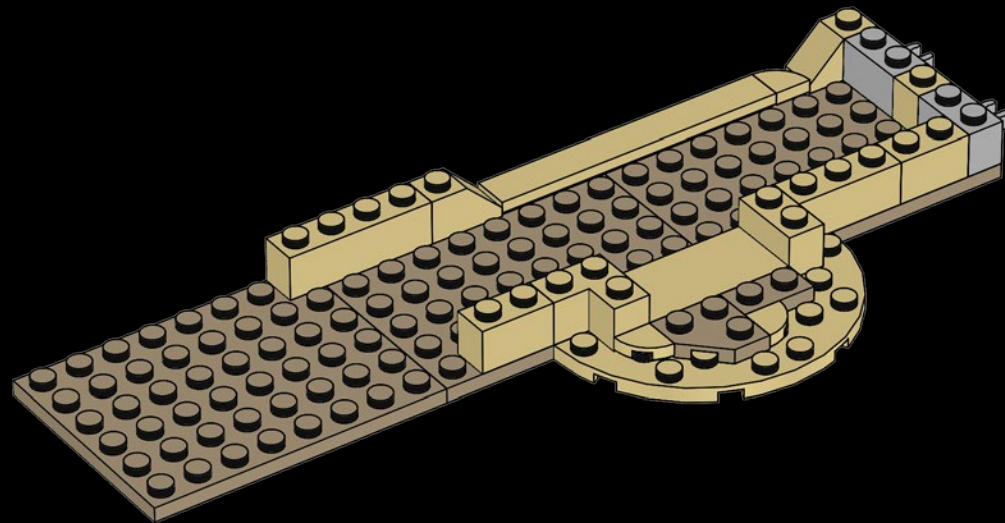

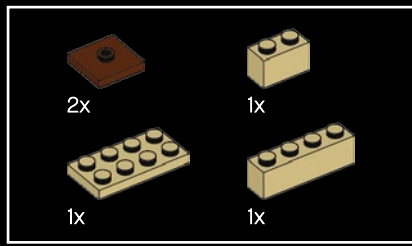

453

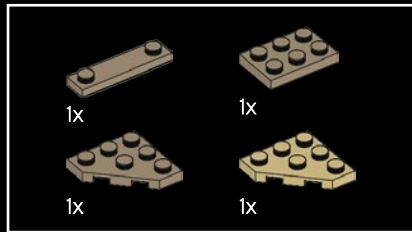
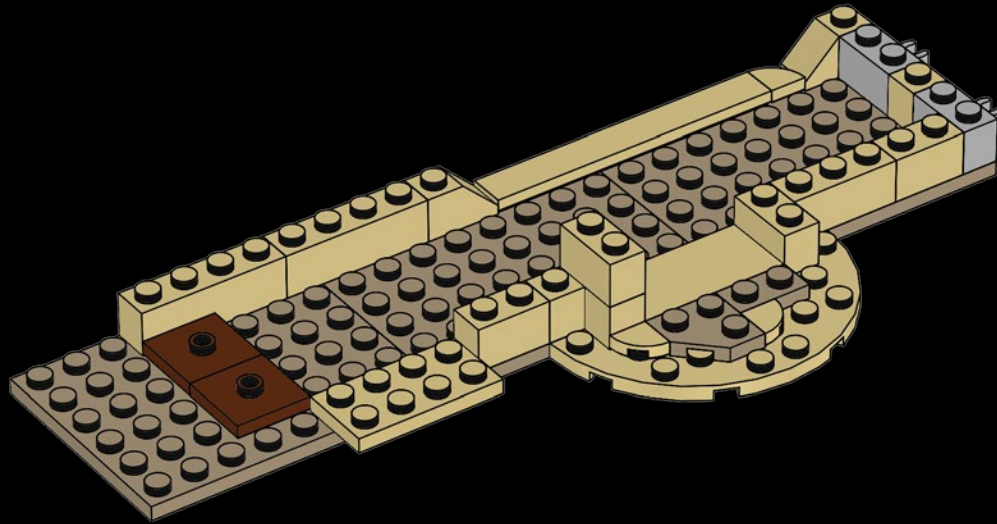

454

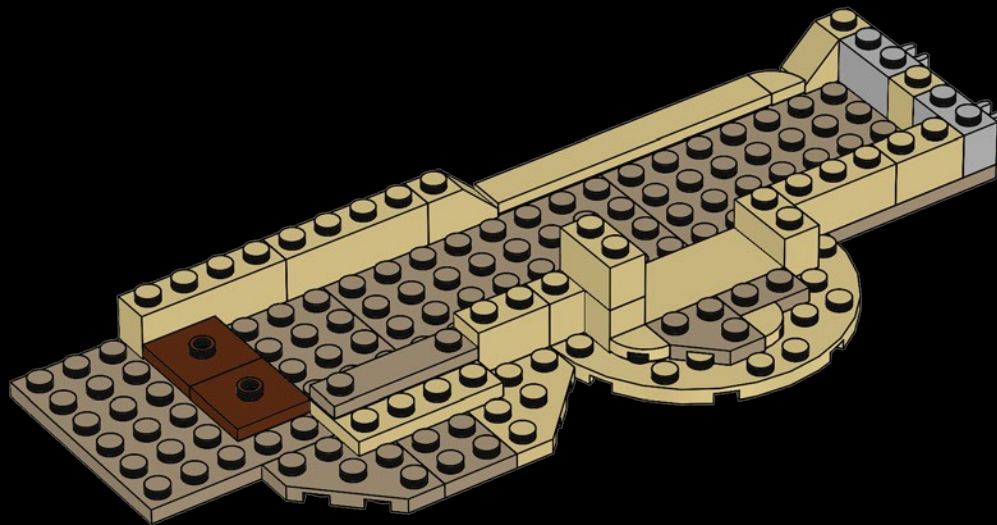

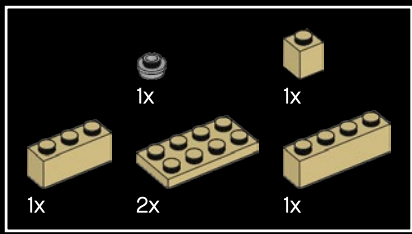

455

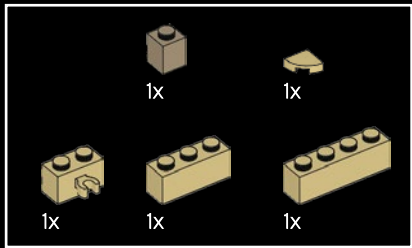
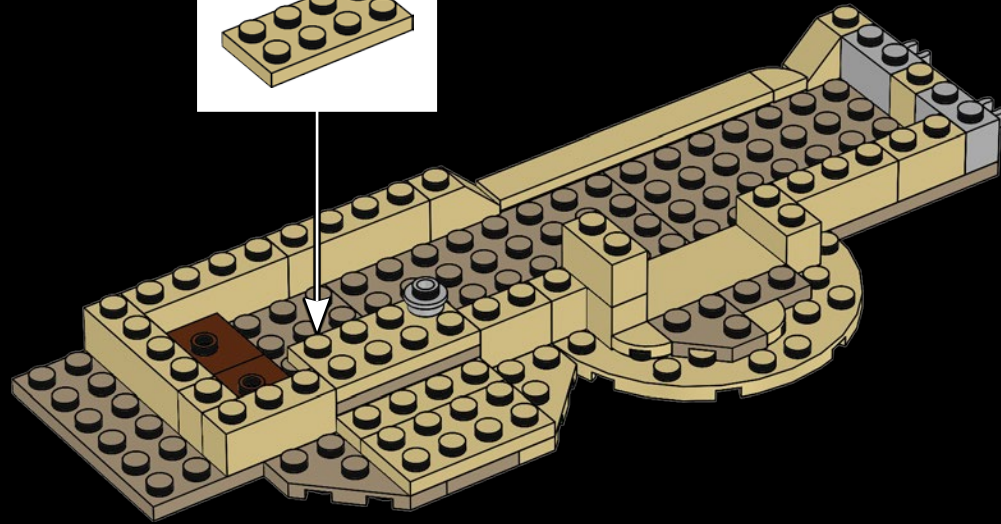
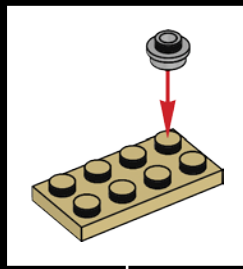

456

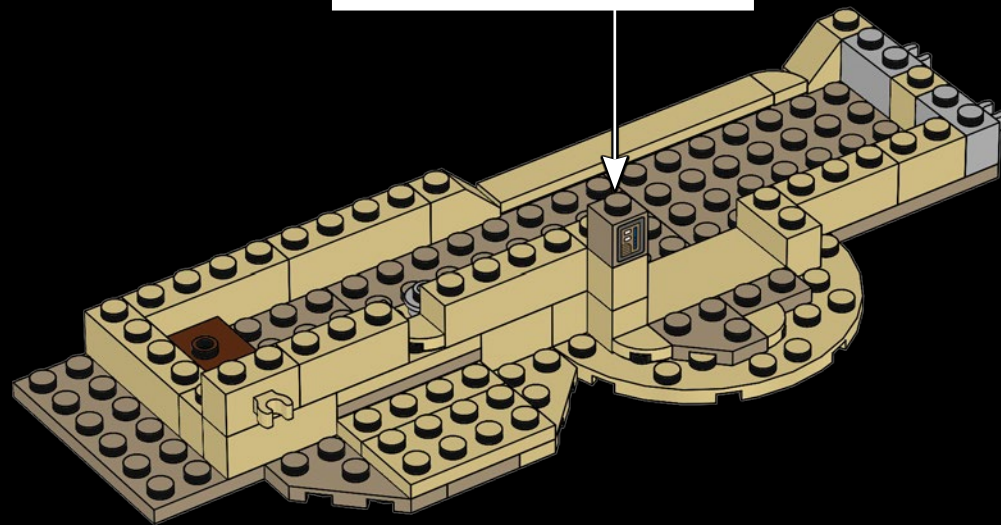
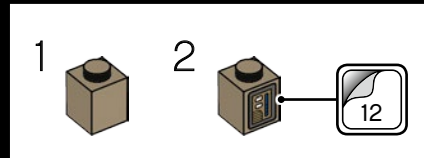

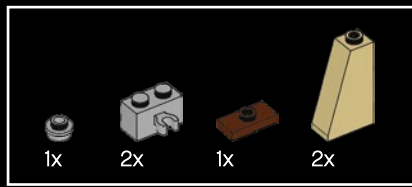

457

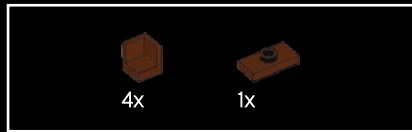
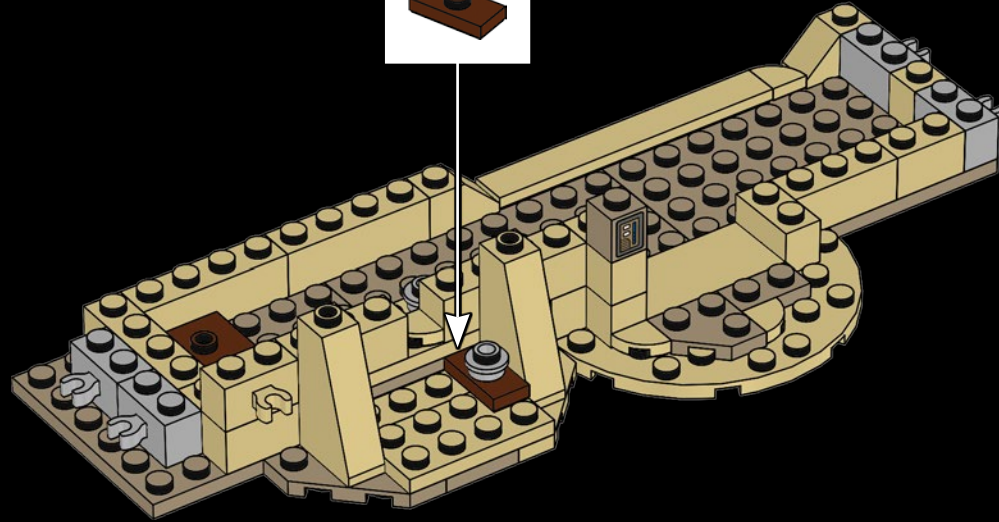
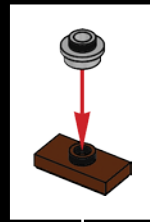

458

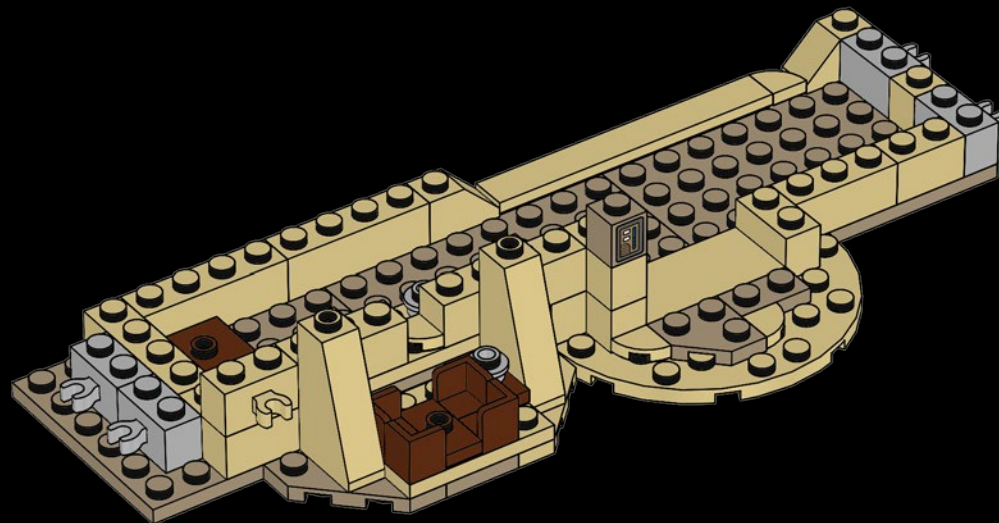

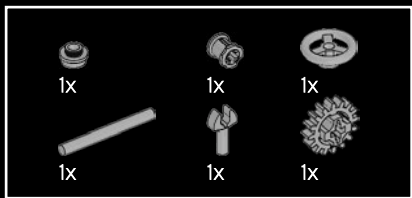

459

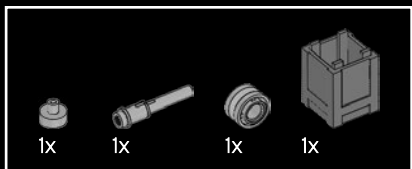
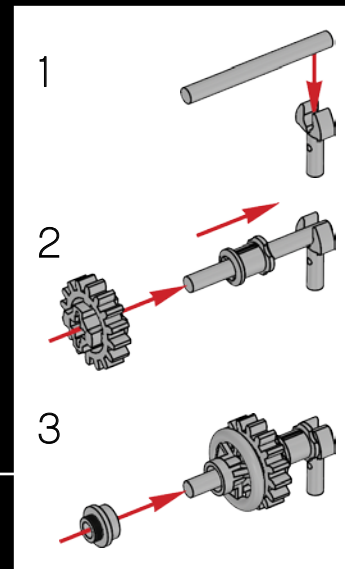
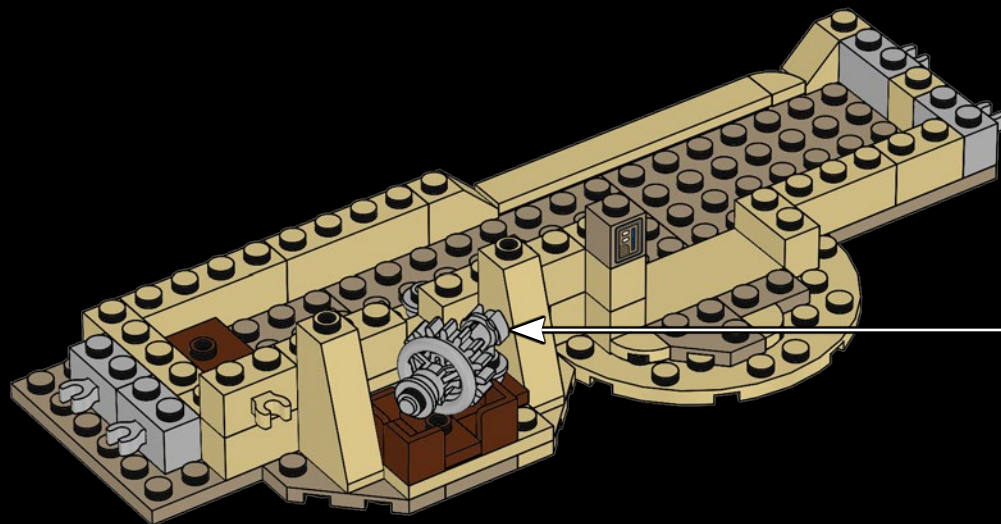

460

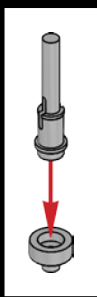
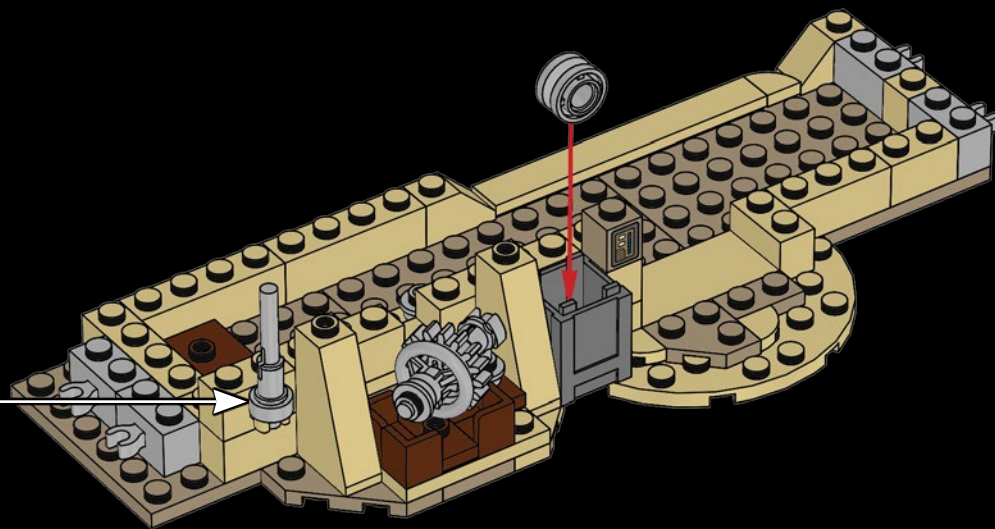

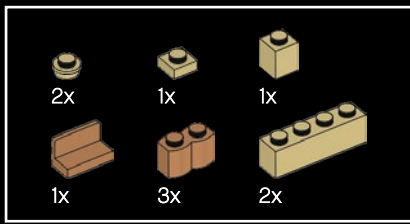

461

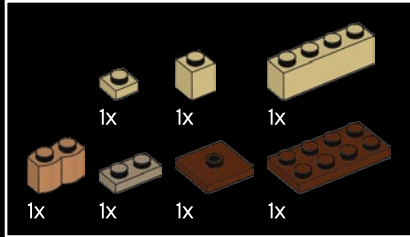
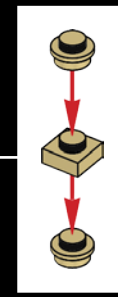
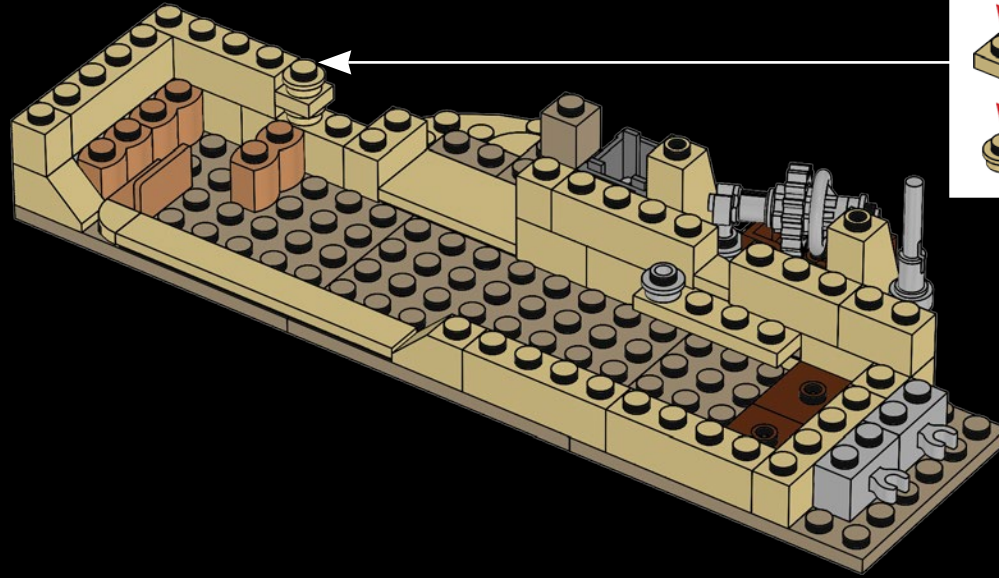

462

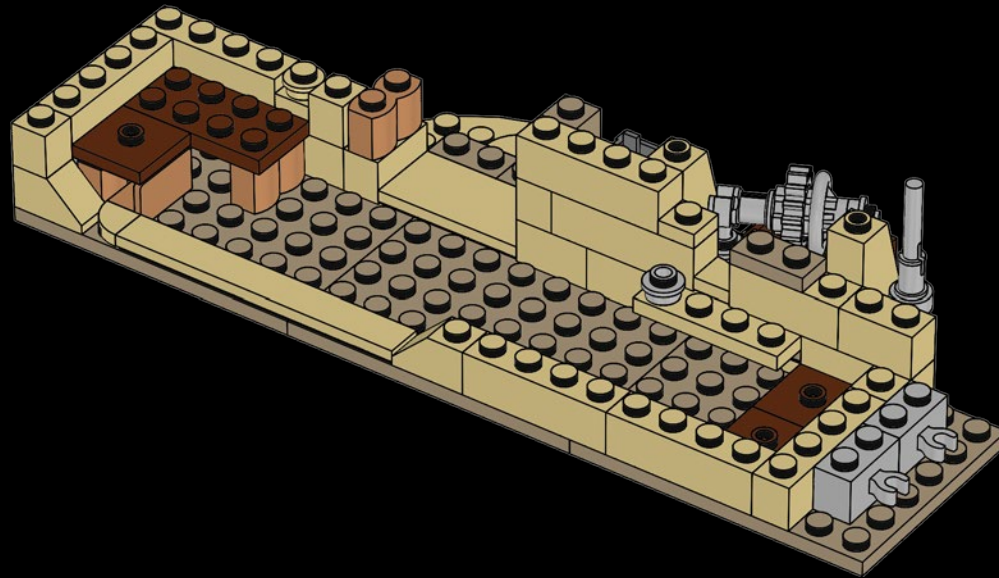

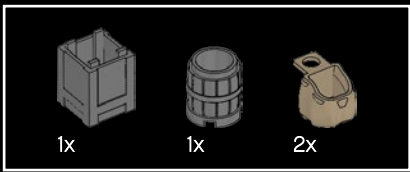

463

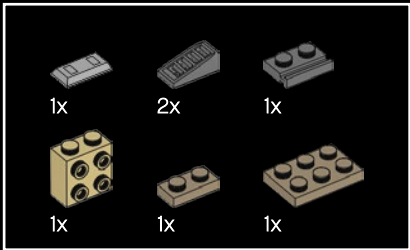
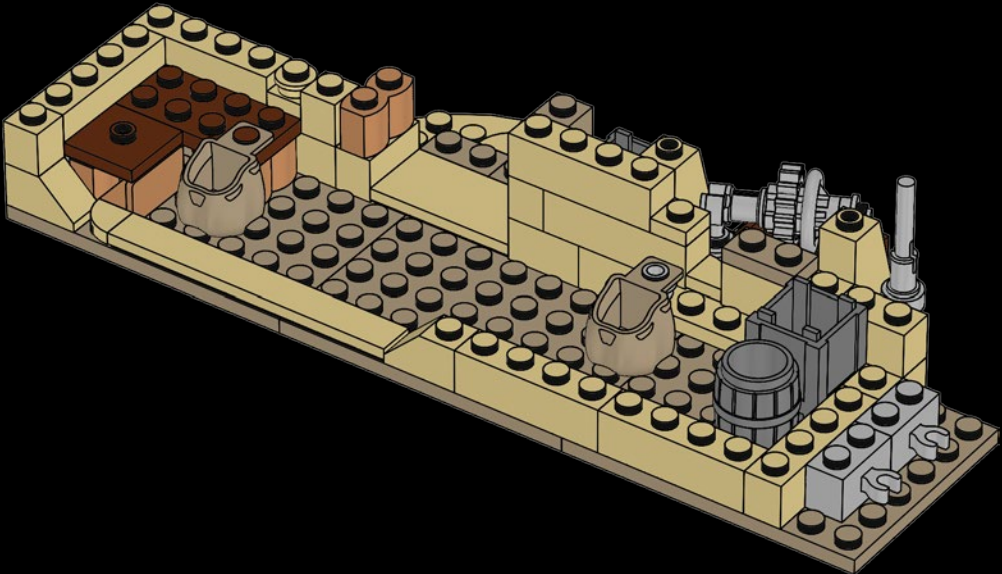

464

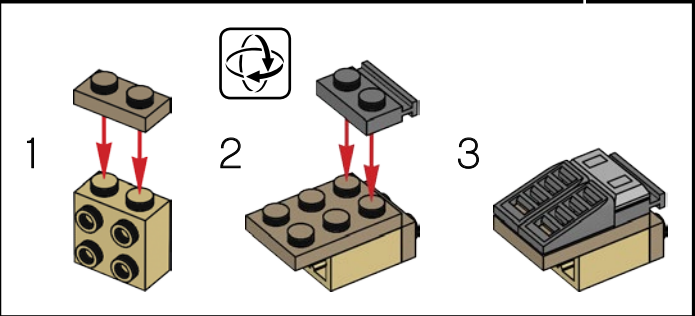
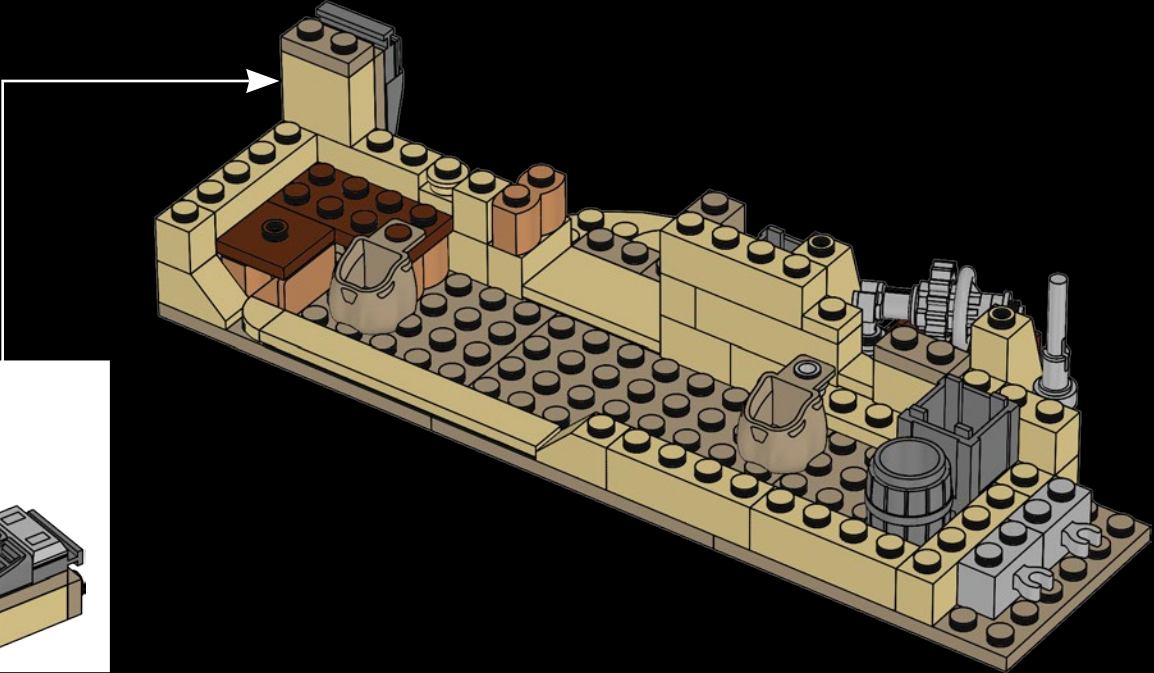

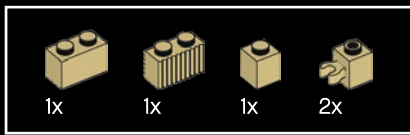

465

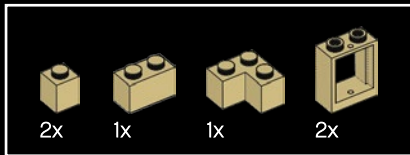
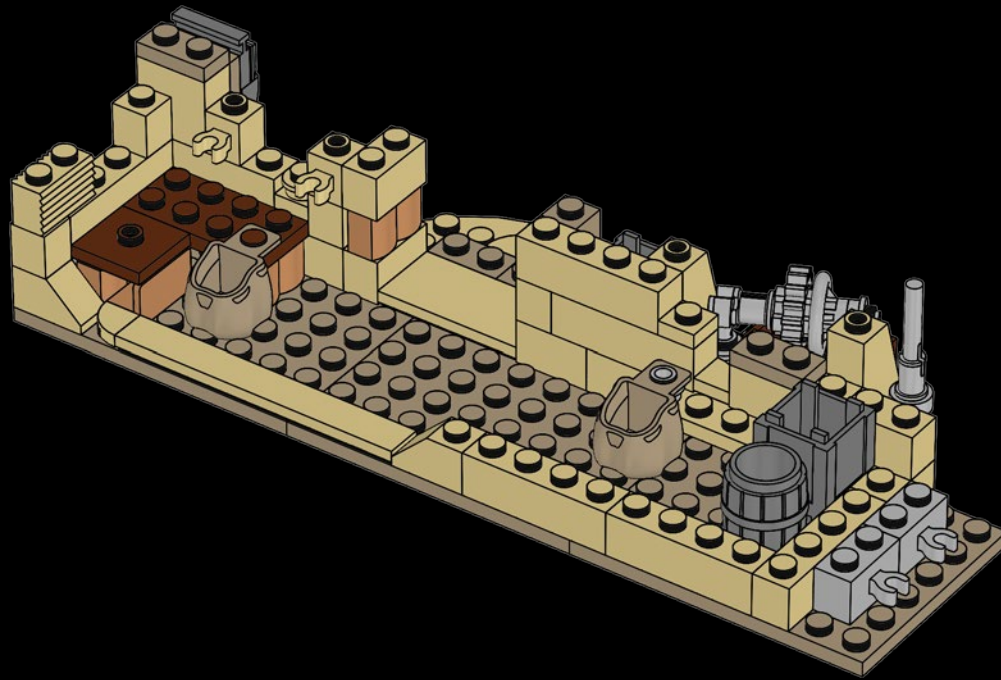

466

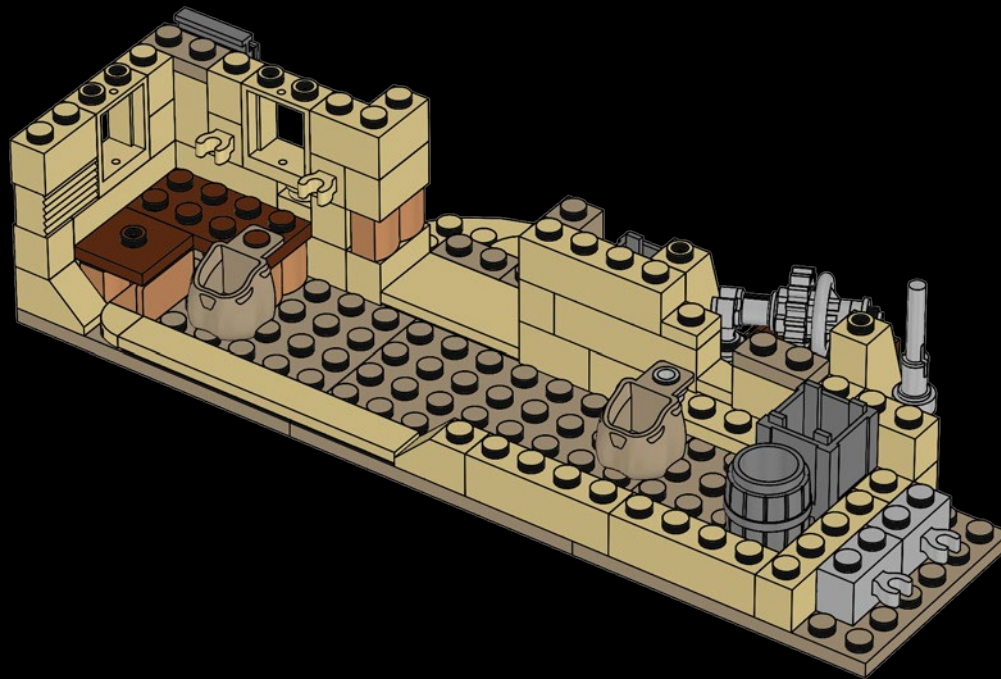



467

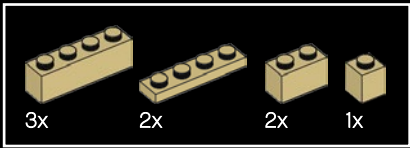
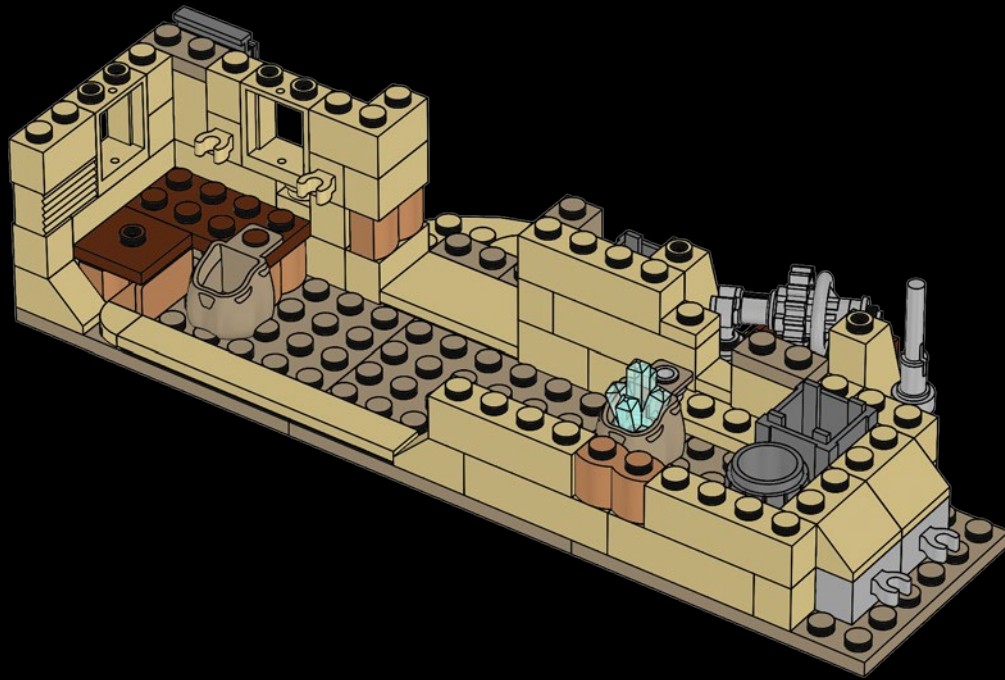

468

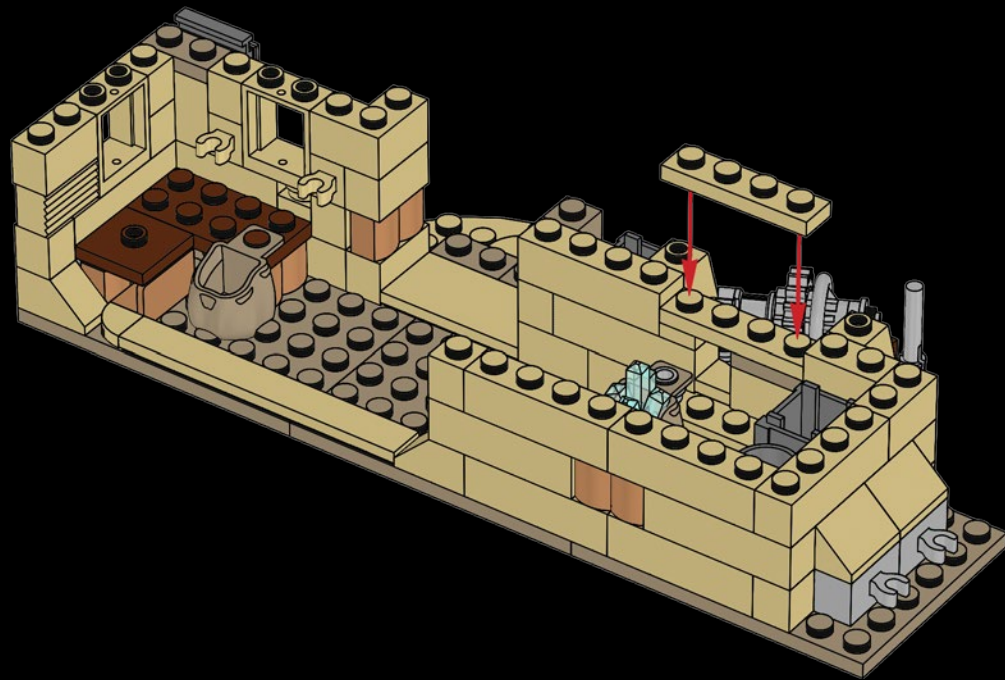

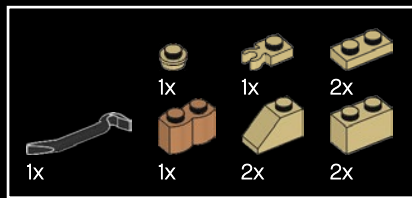

469

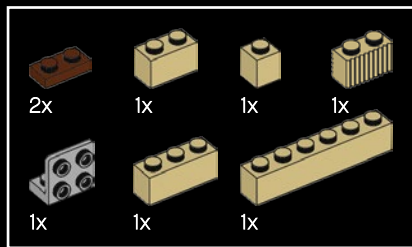
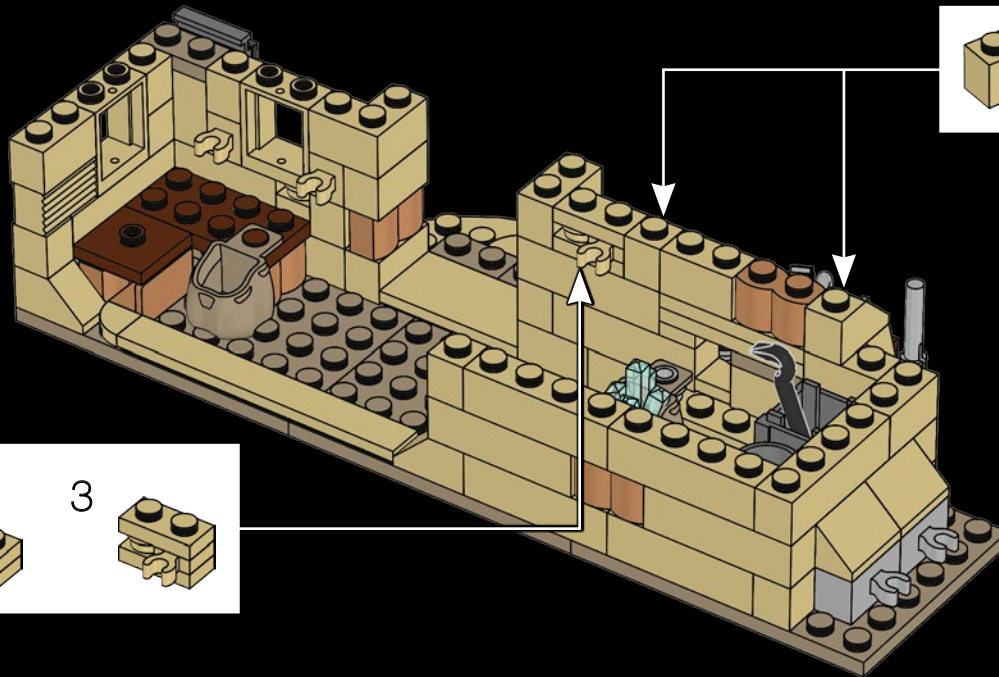
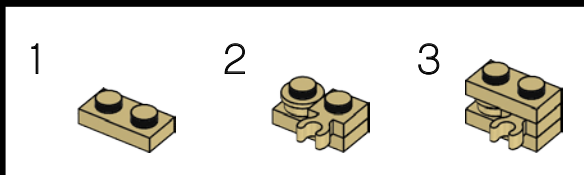
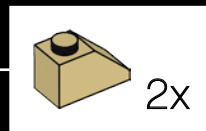

470

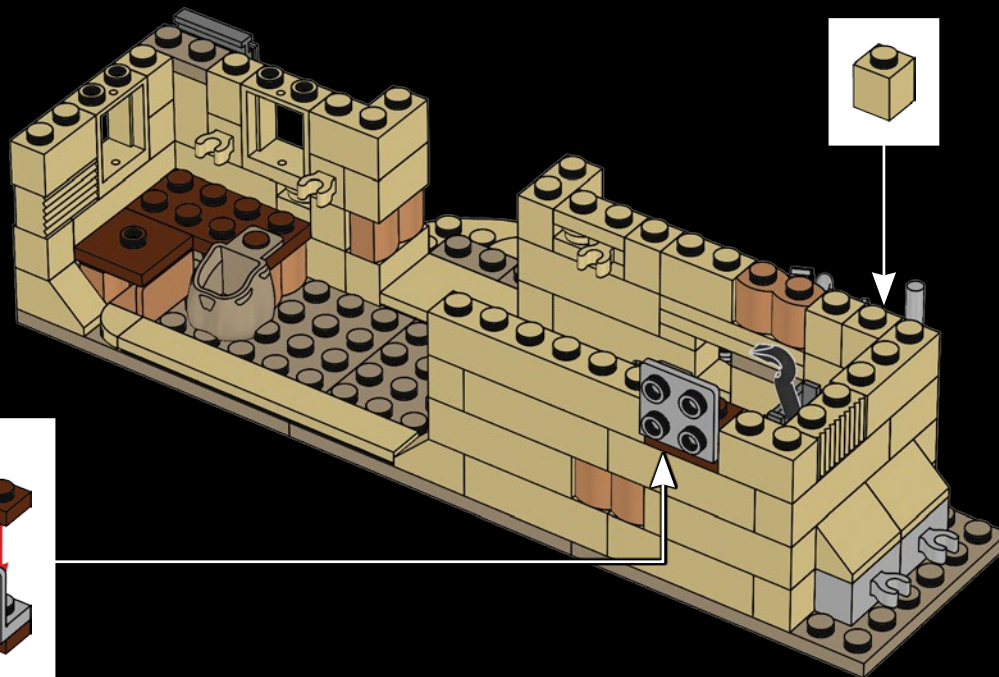
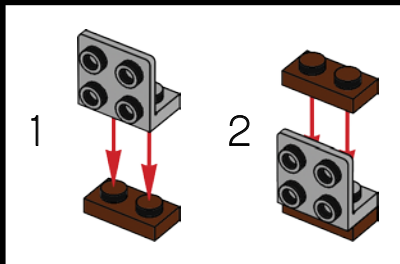
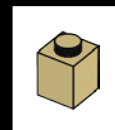

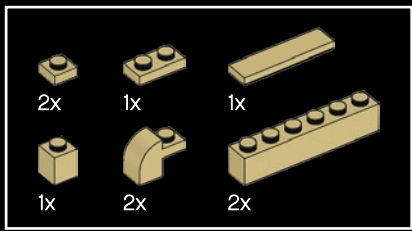

471

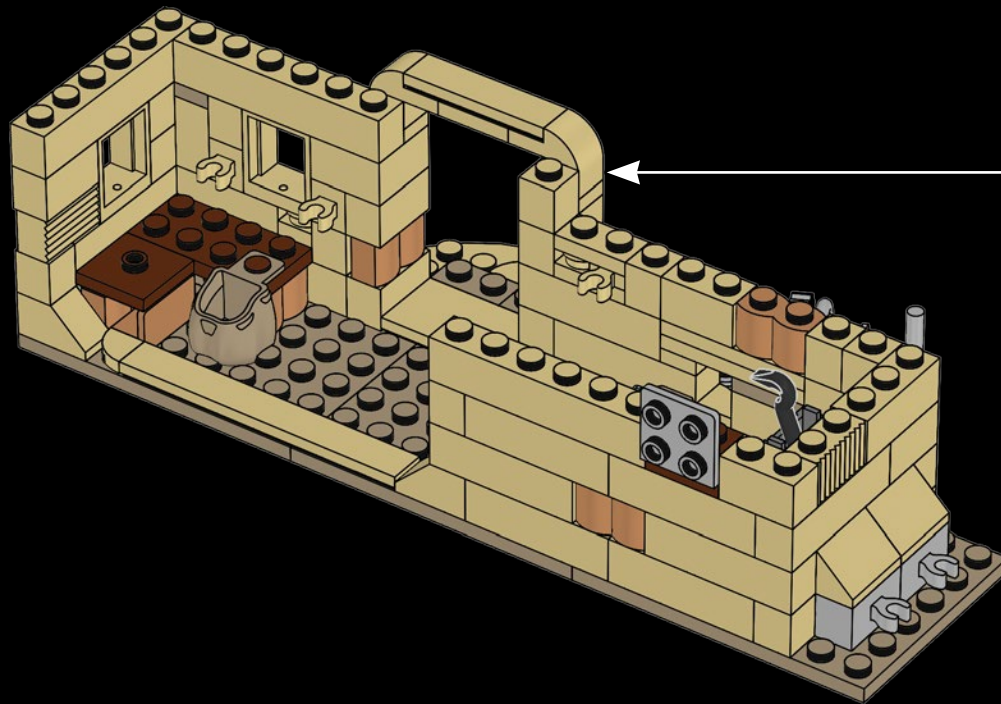
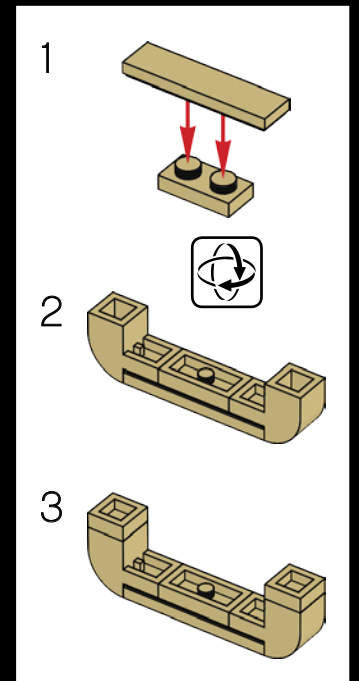

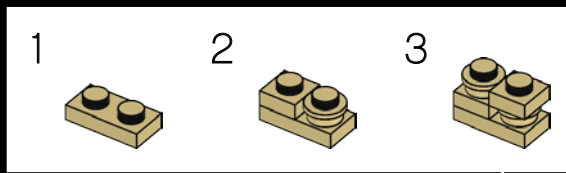
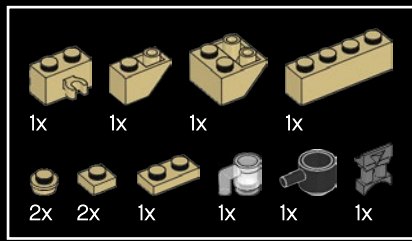

472

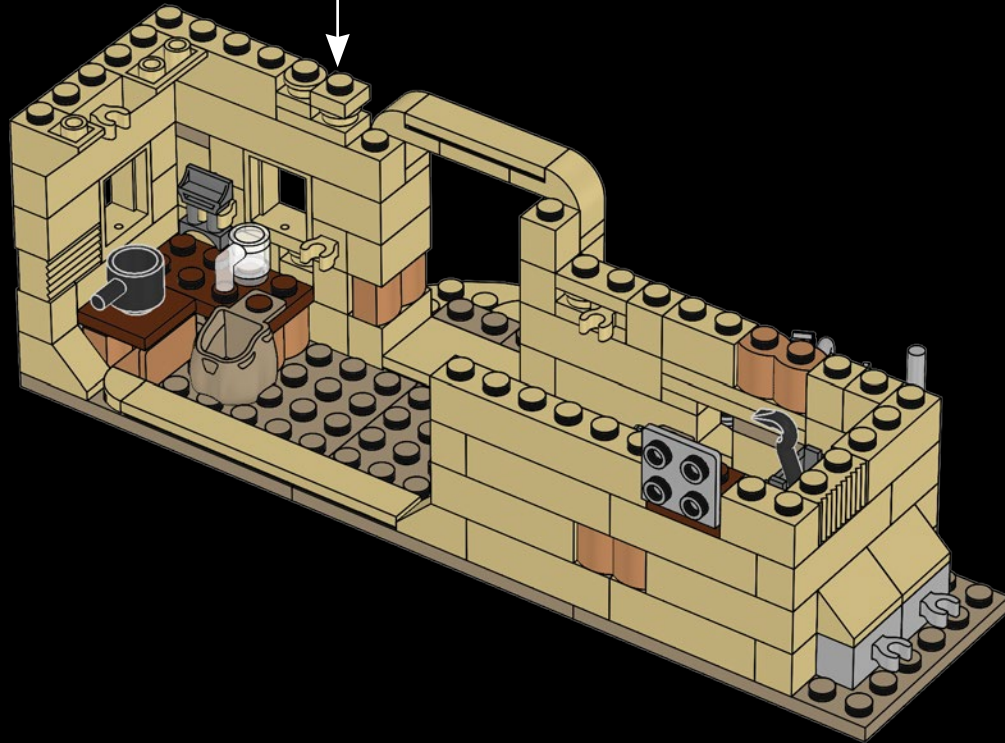

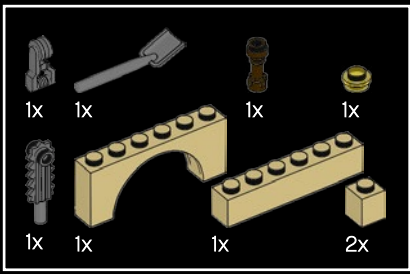

473

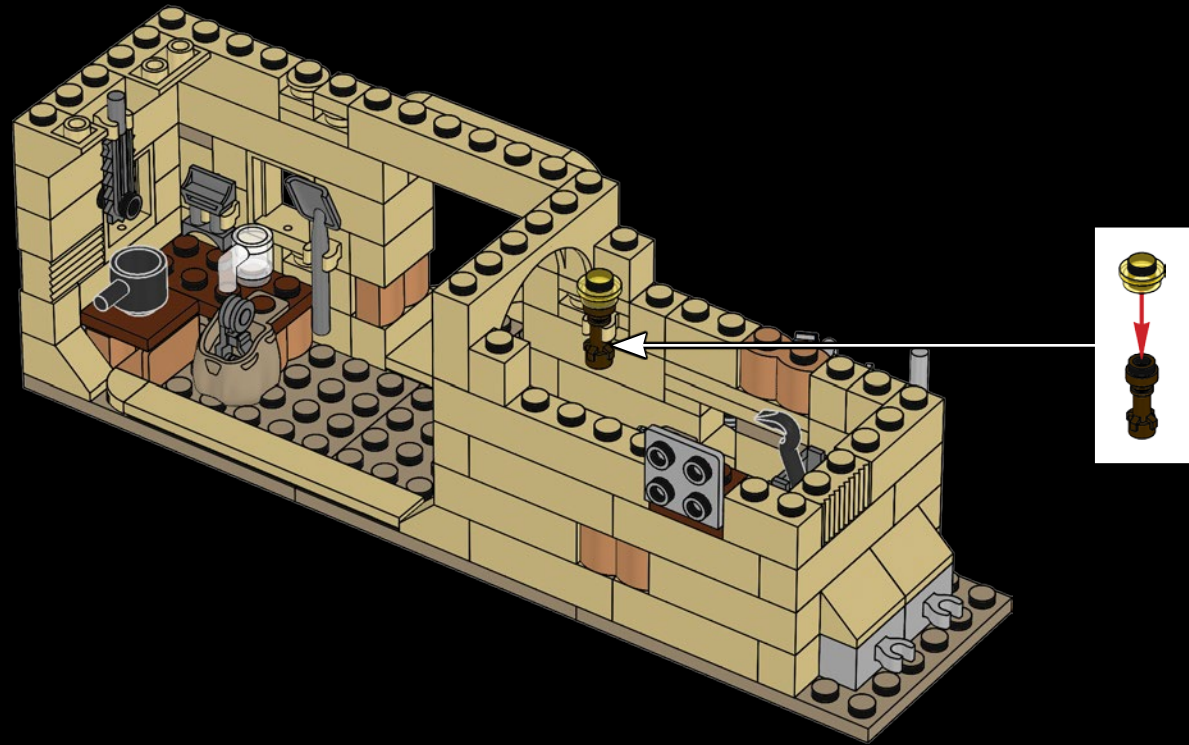

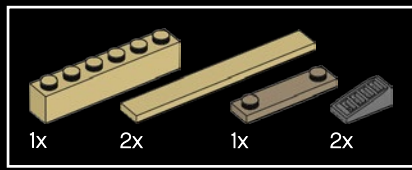

474



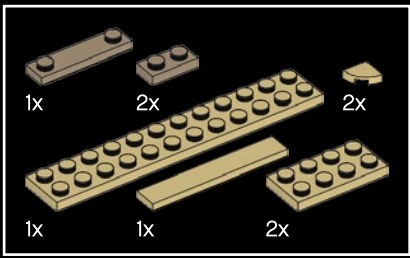

475

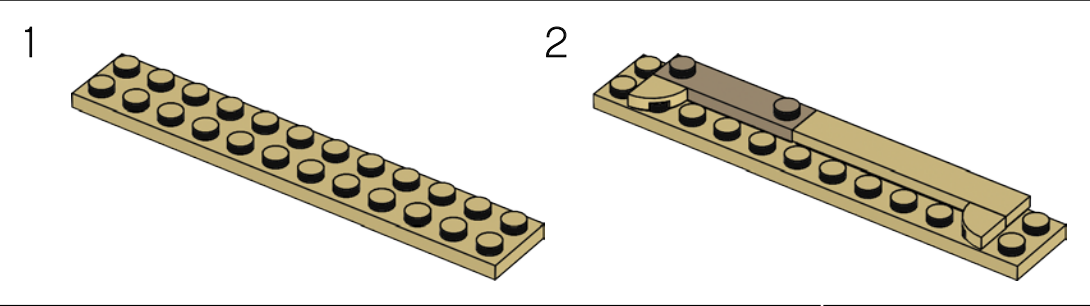

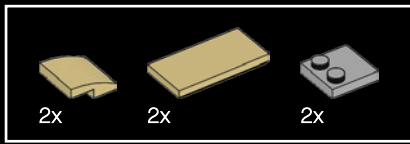

476

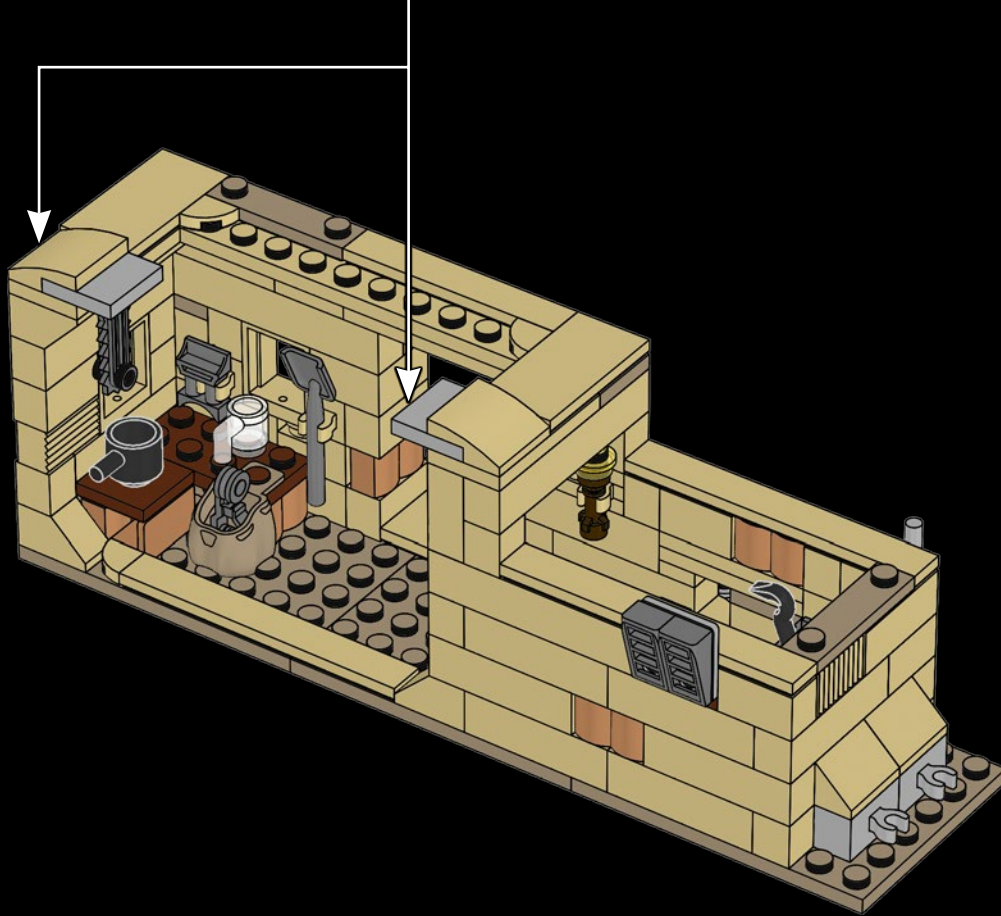
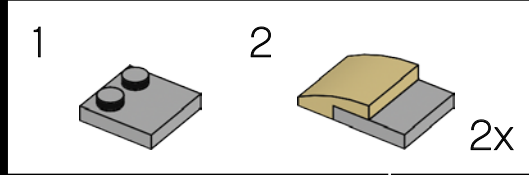

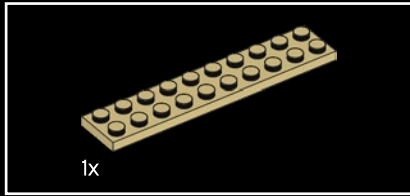
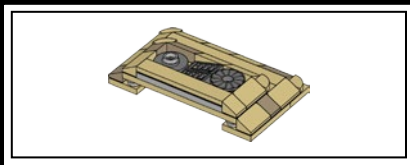

477

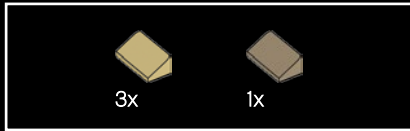
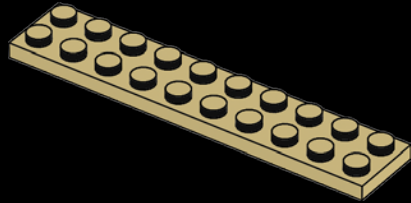

478

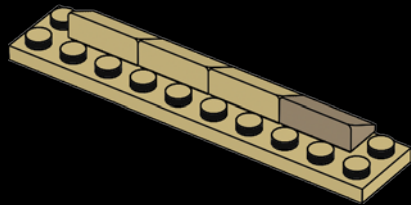

479

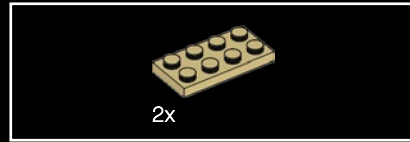
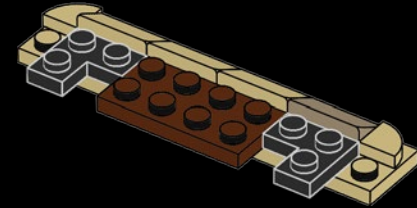

480

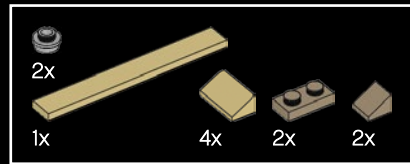
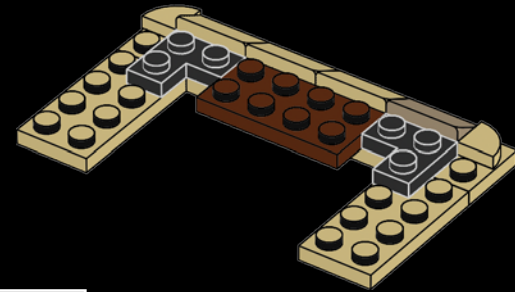

481

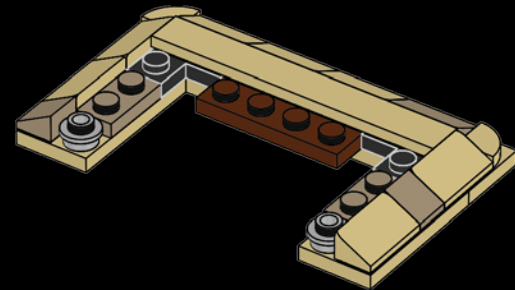

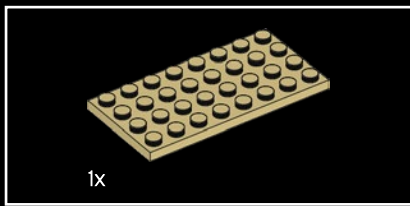

1x

482

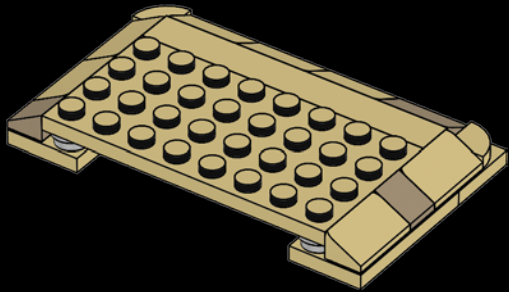

2x

2x

1x

483

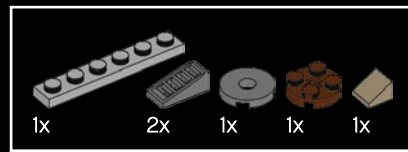
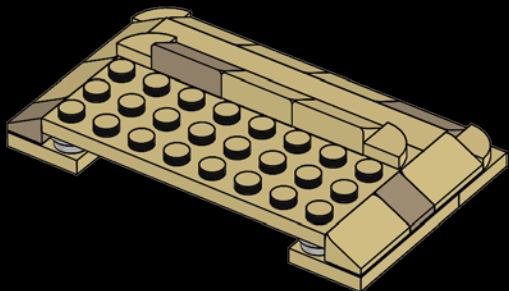

1x

2x

1x

1x

1x

484

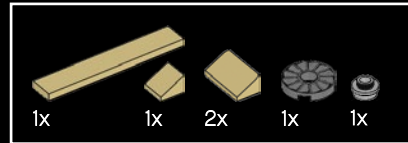
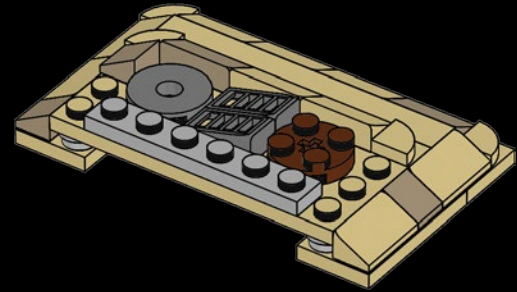

1x

1x

2x

1x

1x

485

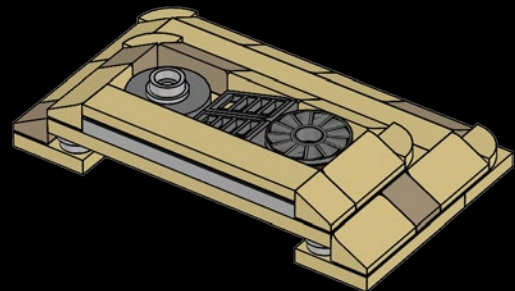

486



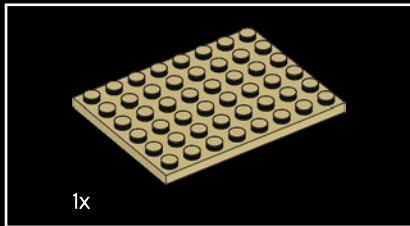
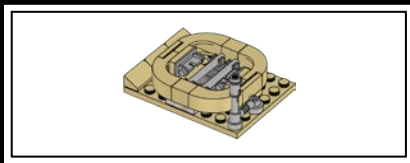

1x

487

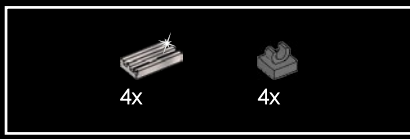
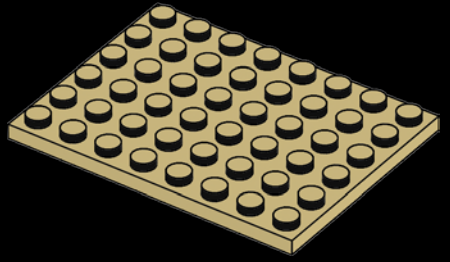

488

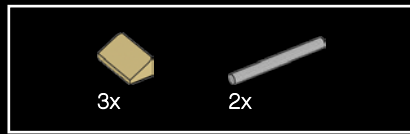
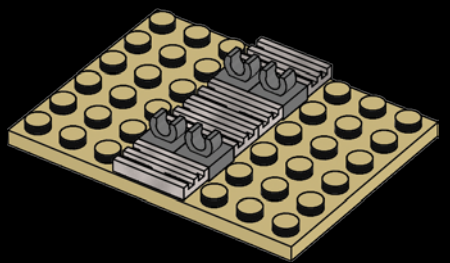

489

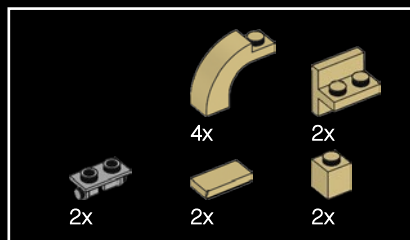
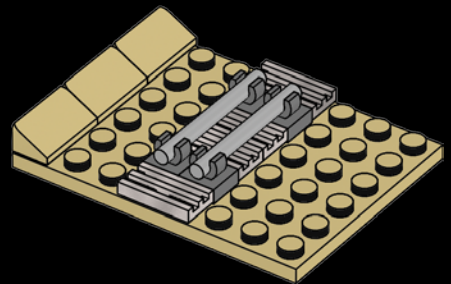

490

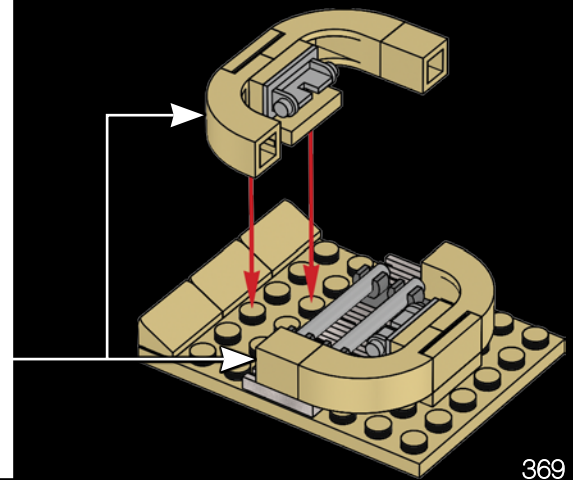
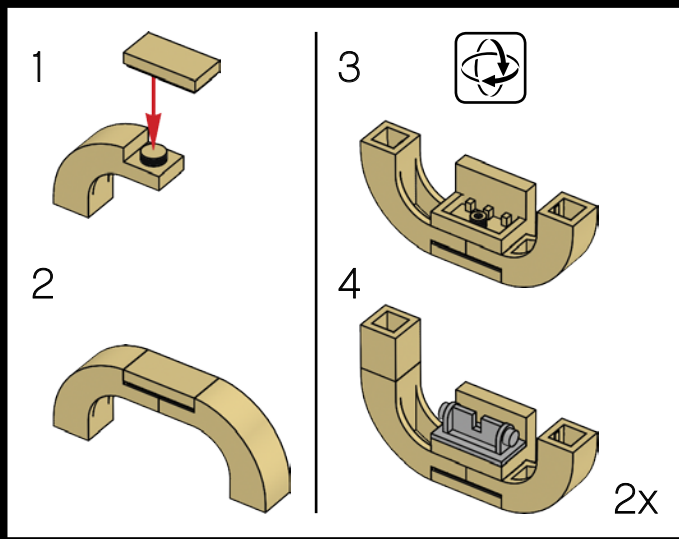



491

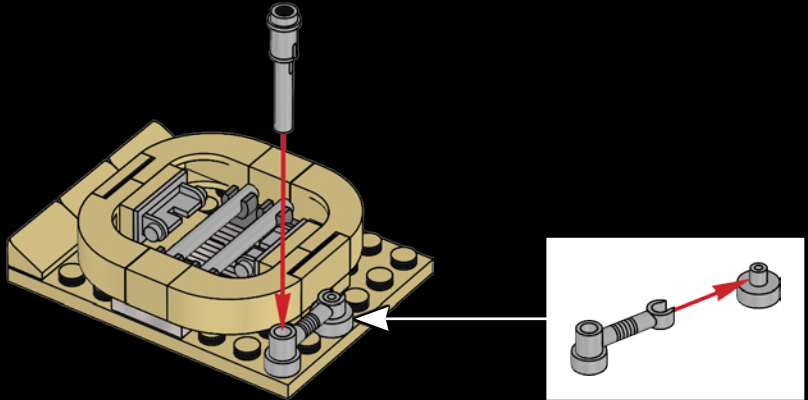

492

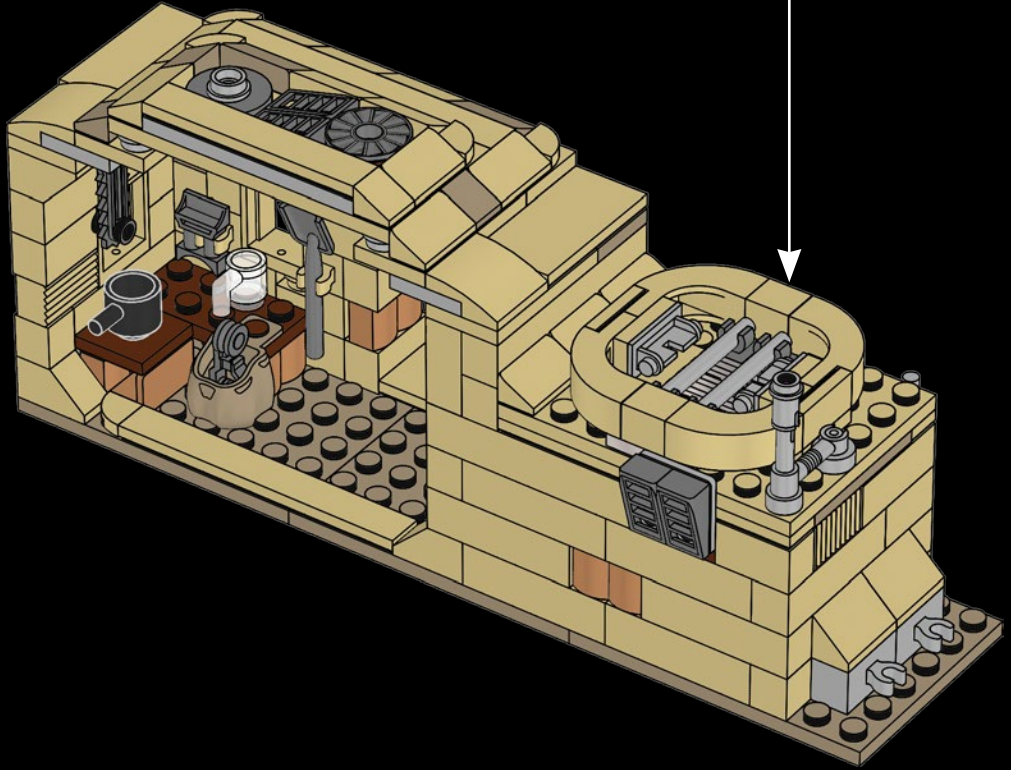

493

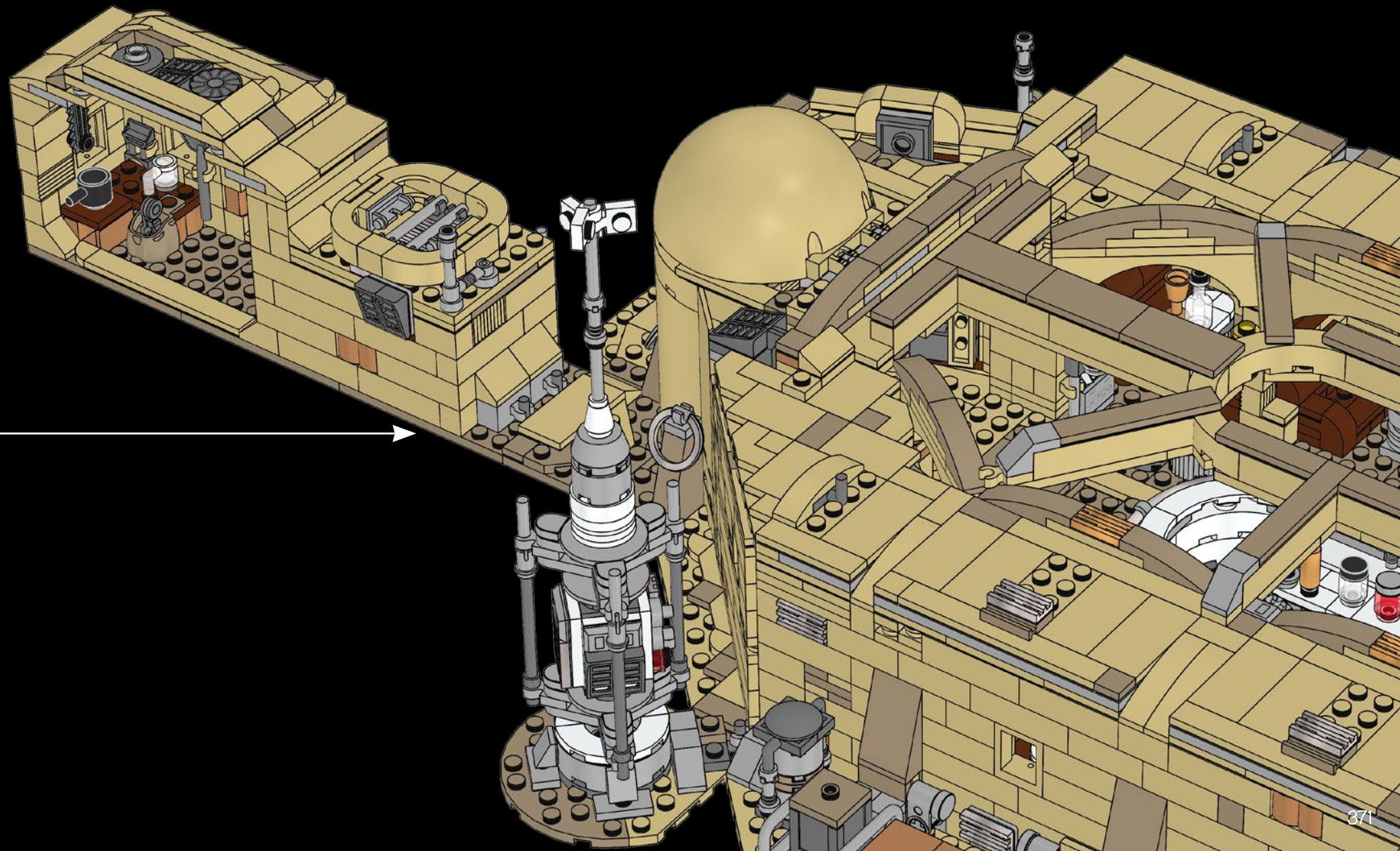

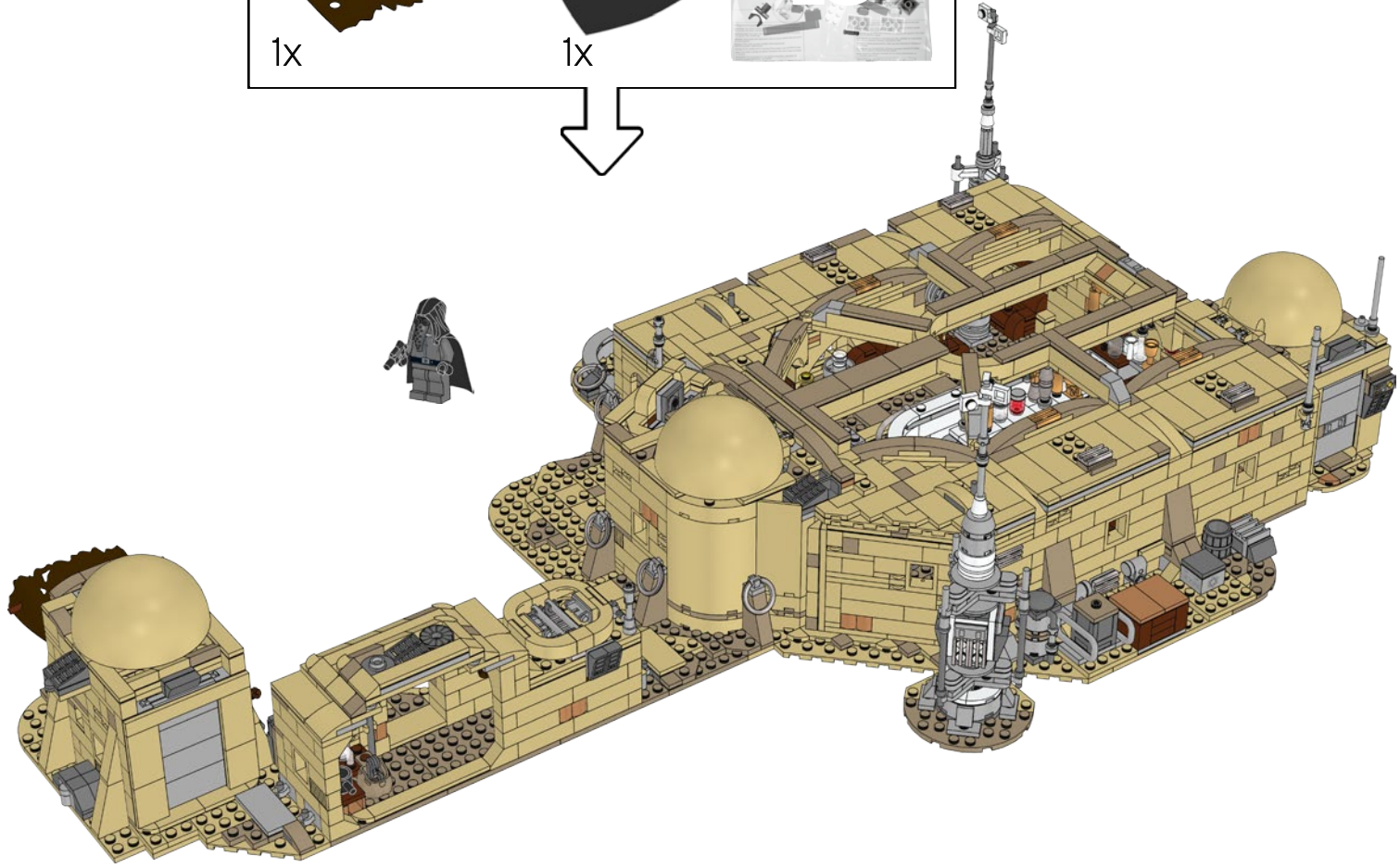
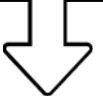
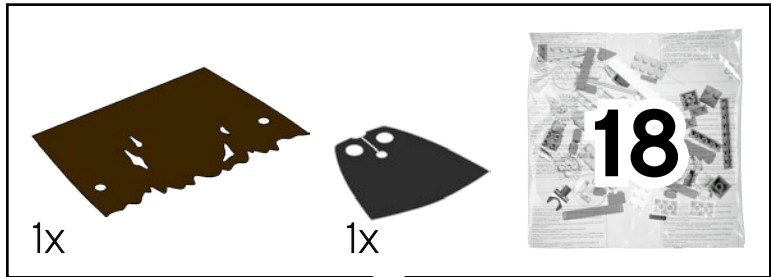

Garindan is a member of the long-snouted Kubaz species from the planet Kubindi. He made a living as an Imperial informant during the Galactic Civil War. In *Star Wars: A New Hope*, he tracks R2-D2 and C-3PO to Docking Bay 94 where they make their narrow escape on the Millennium Falcon.

Garindan fait partie des Kubaz, une espèce à longue trompe de la planète Kubindi. Il a gagné sa vie en tant qu'informateur impérial pendant la Guerre Civile Galactique. Dans *Star Wars : Un Nouvel Espoir*, il suit R2-D2 et C-3PO à la baie d'amarrage 94, d'où ils s'échappent de justesse à bord du Faucon Millenium.

Garindan pertenece a la especie Kubaz, originaria del planeta Kubindi y caracterizada por su largo hocico. Se ganaba la vida filtrando información al Imperio durante la Guerra Civil Galáctica. En *Star Wars: Una Nueva Esperanza*, sigue los pasos de R2-D2 y C-3PO hasta la plataforma 94, desde donde los héroes escapan por poco a bordo del Halcón Milenario.

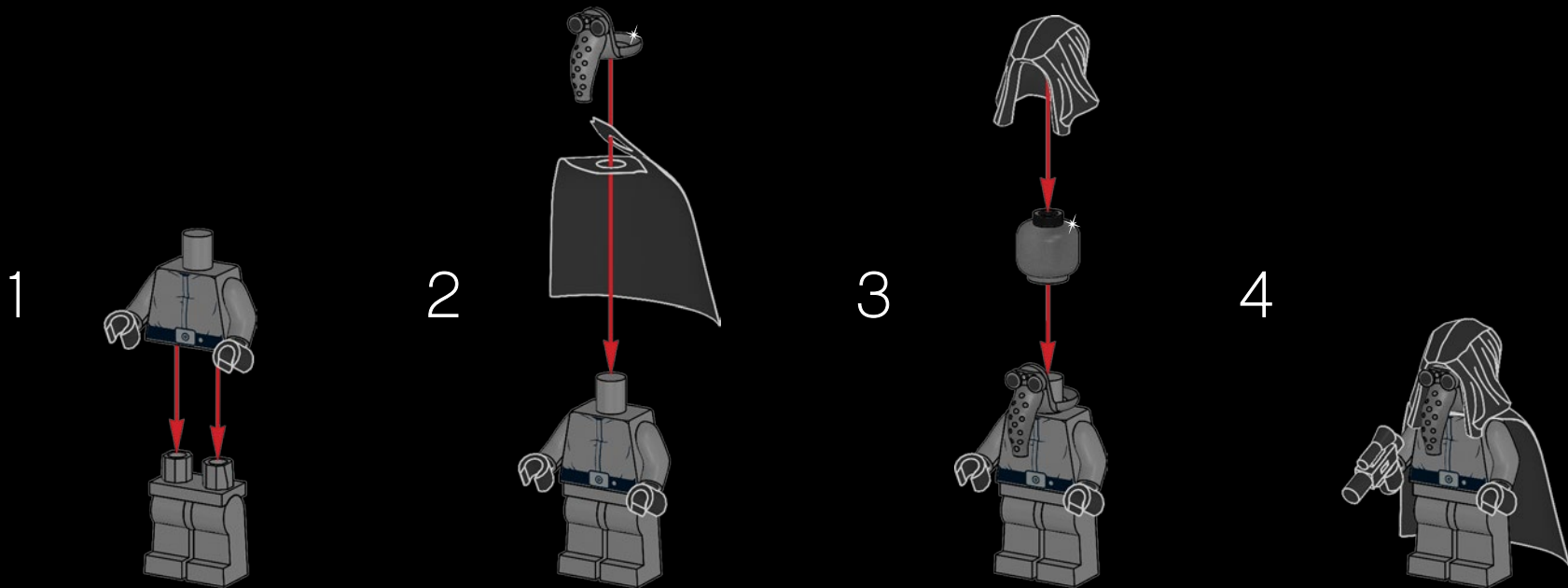

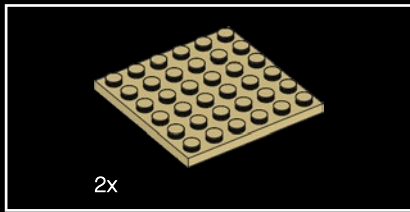
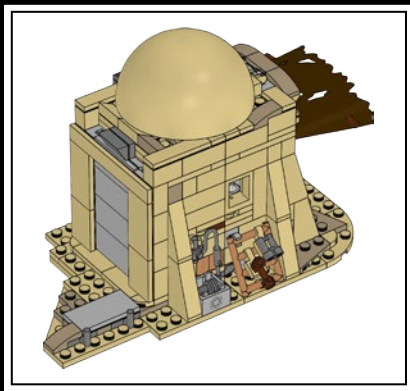

2x

494

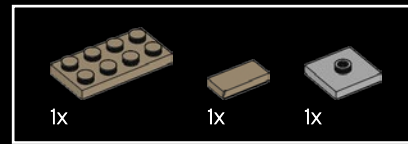
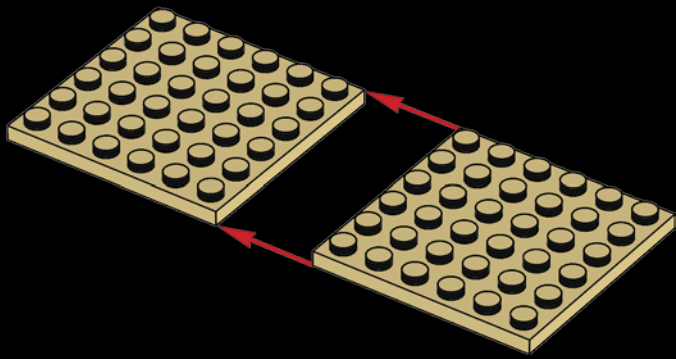

1x

1x

1x

495

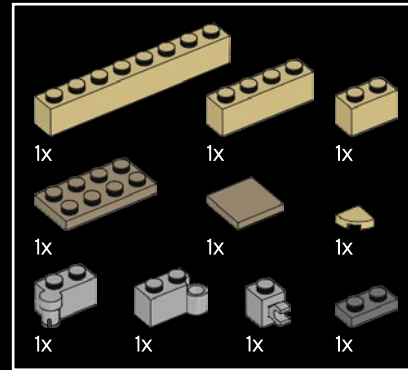
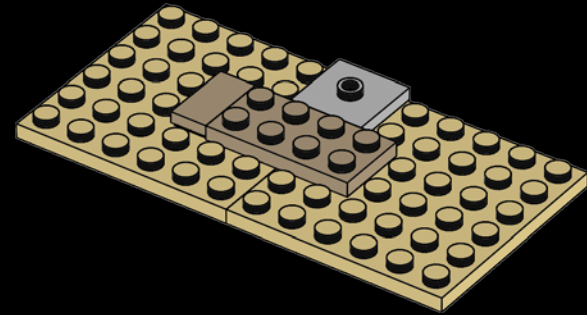

1x

1x

1x

1x

1x

1x

1x

1x

1x

1x

496

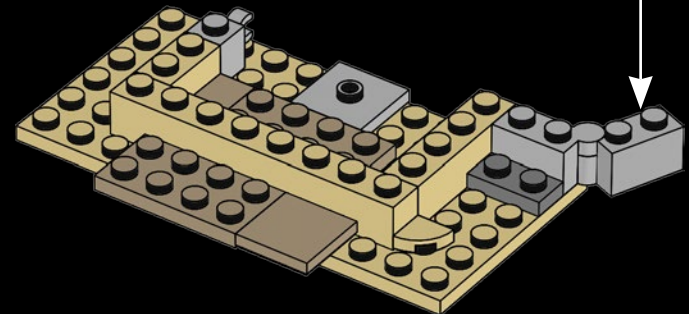
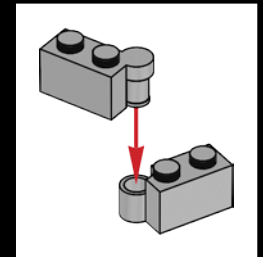

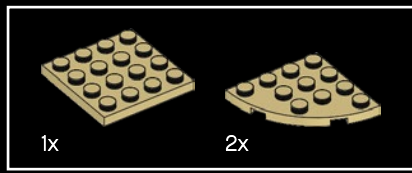

497

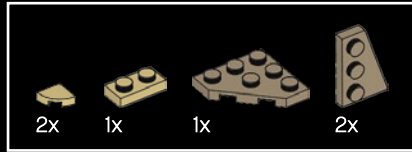
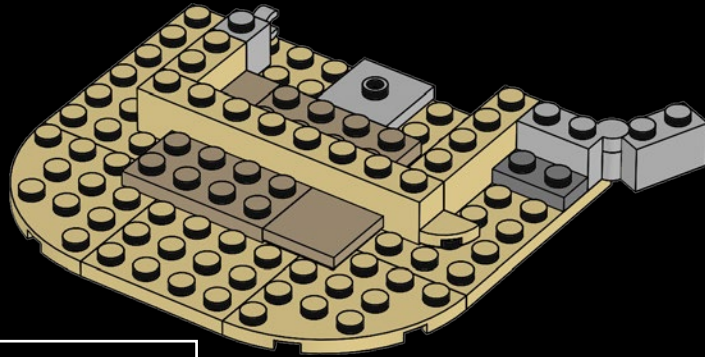

498

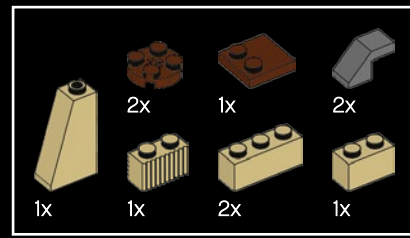
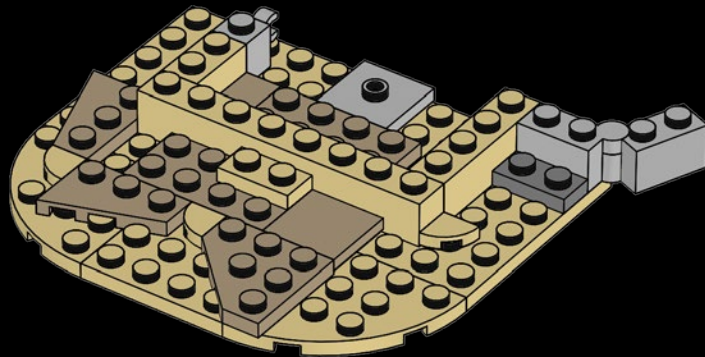

499

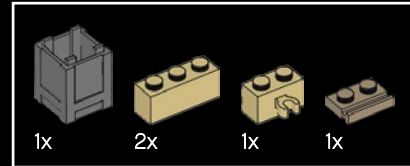
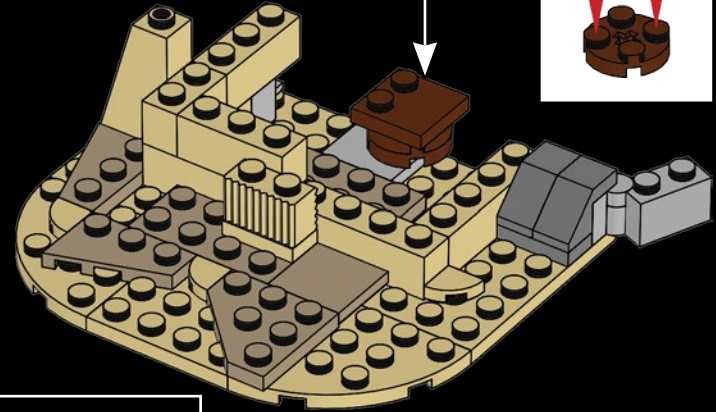

500

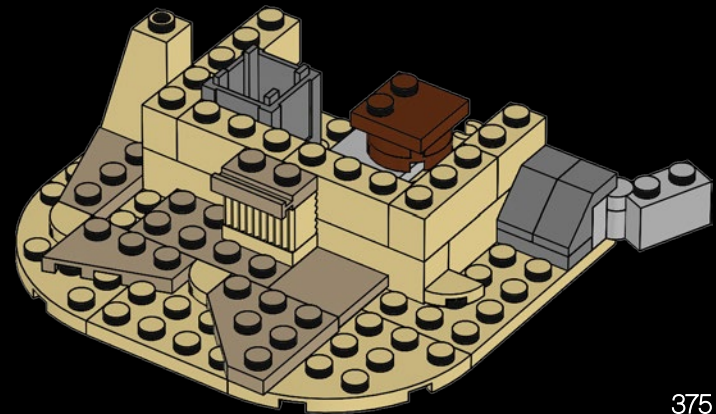

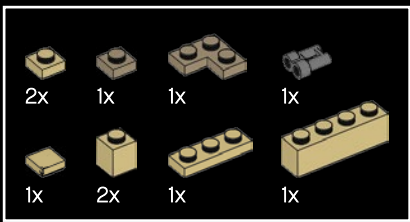

501

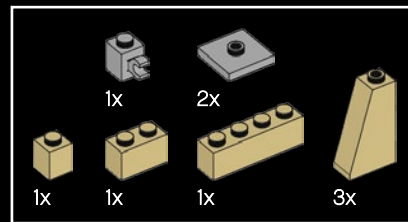
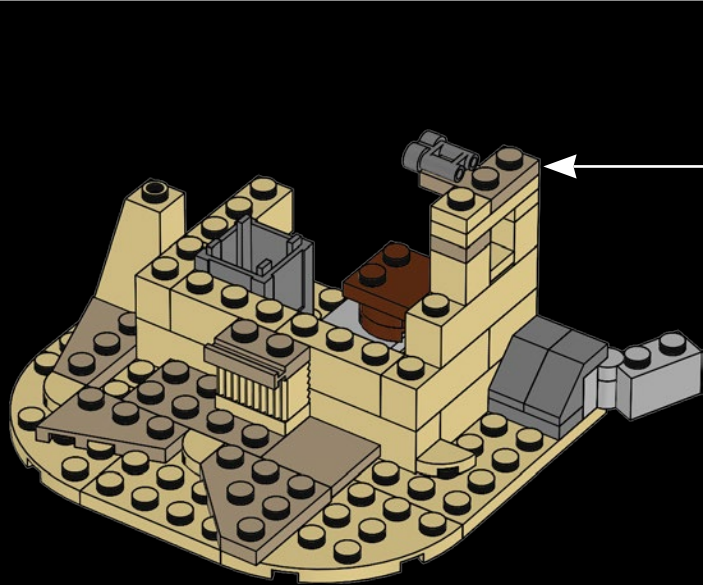
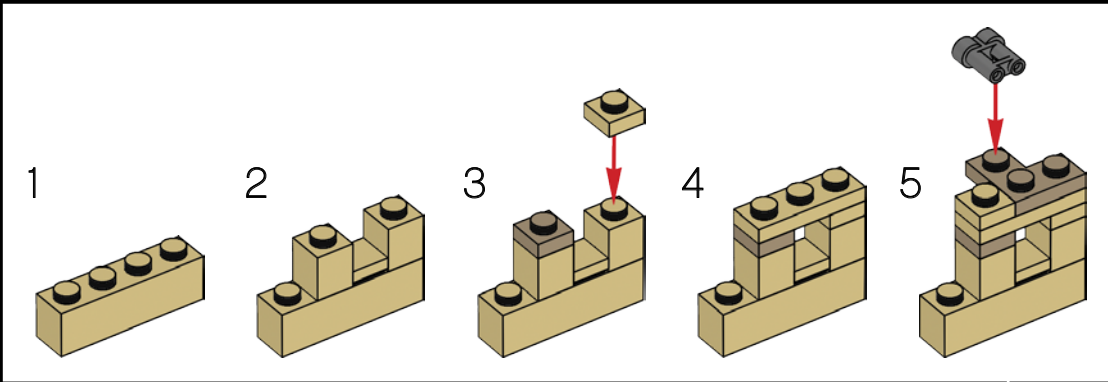

502

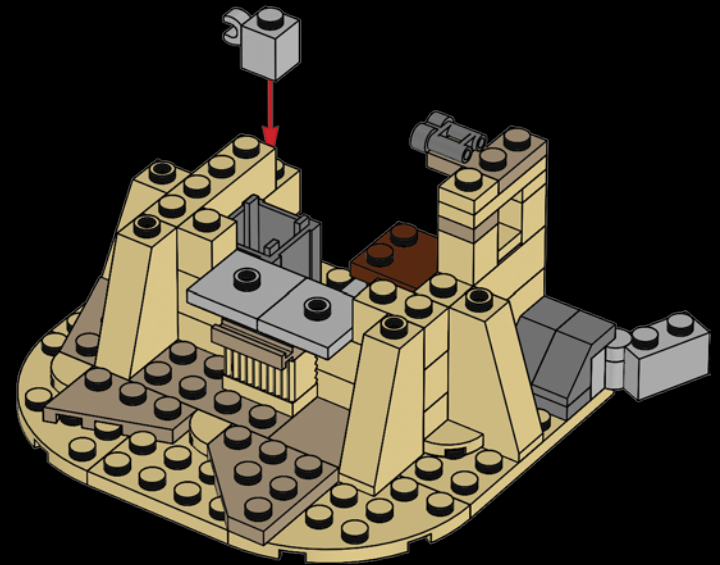

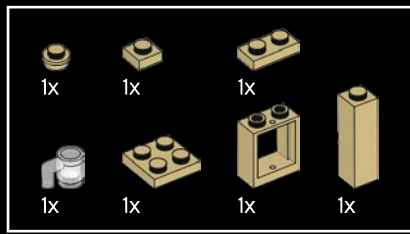

503

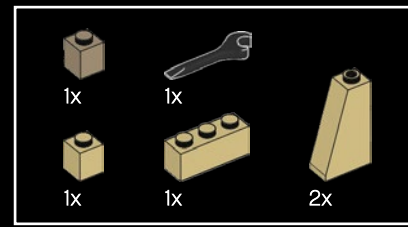
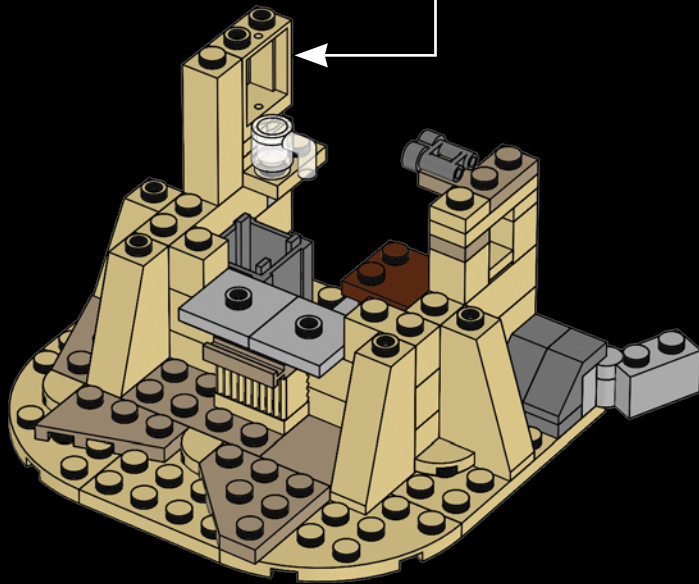
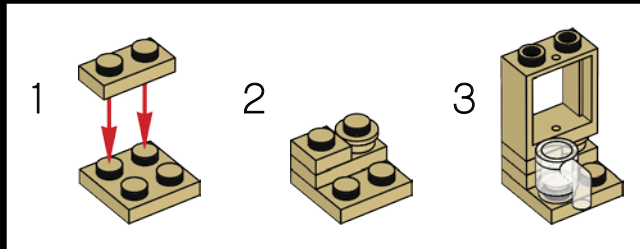

504

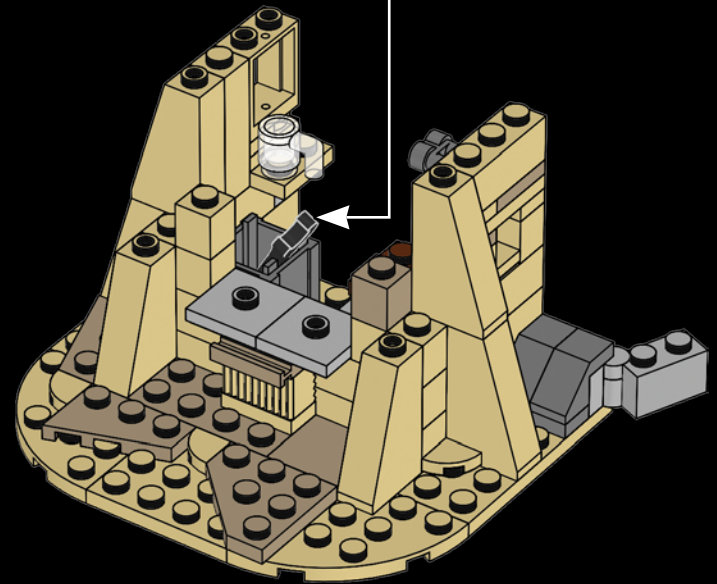

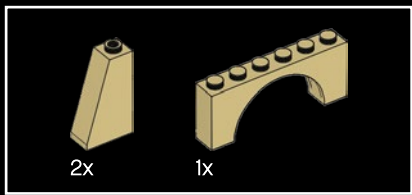

505

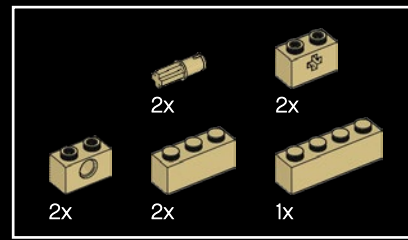
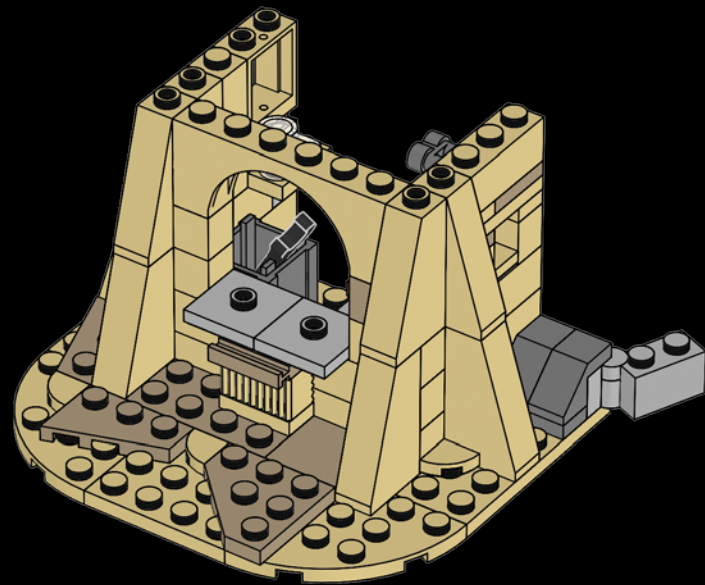

506

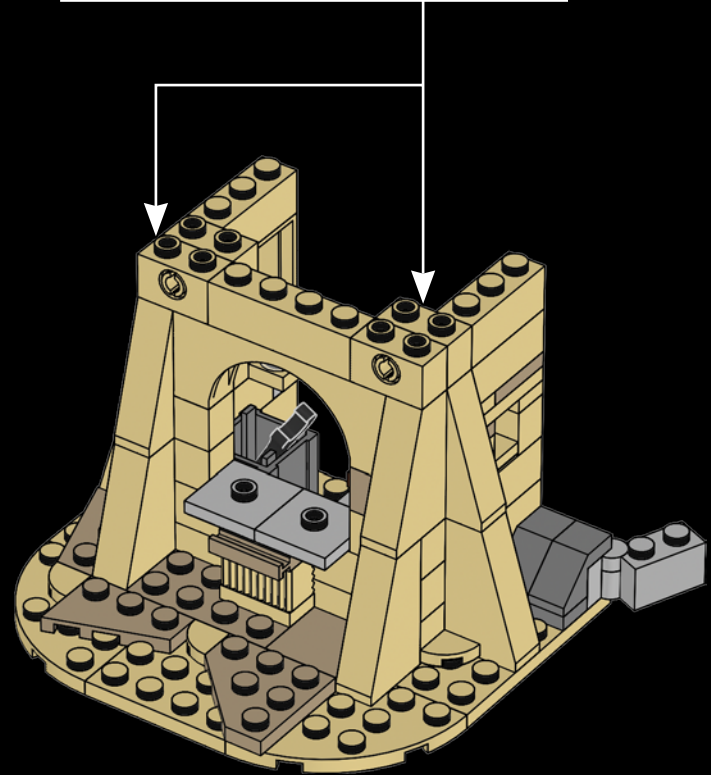
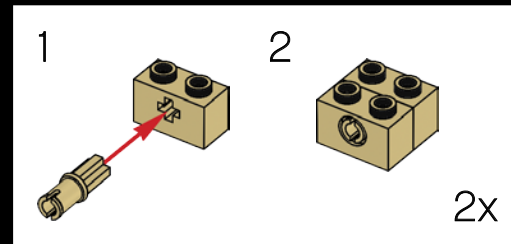

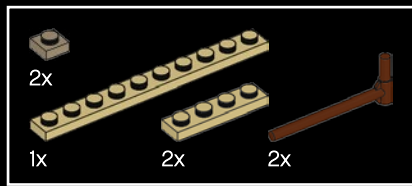

507

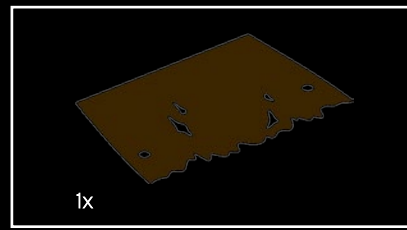
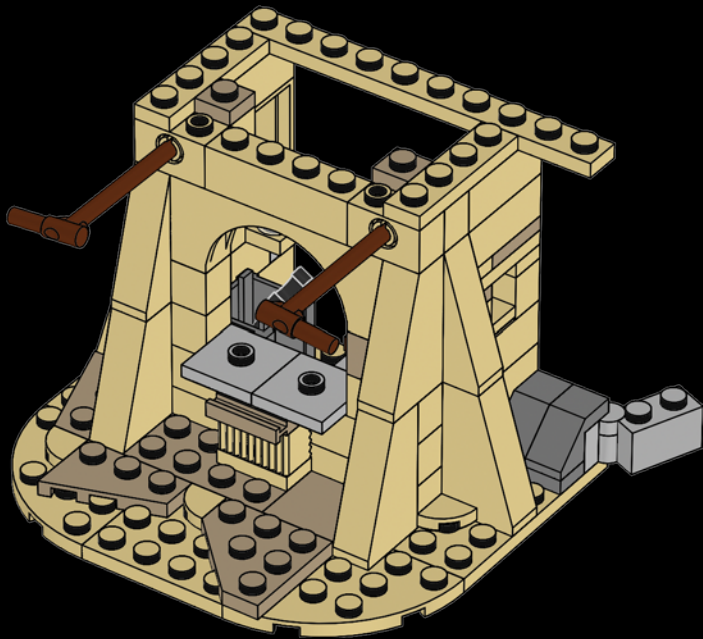

508

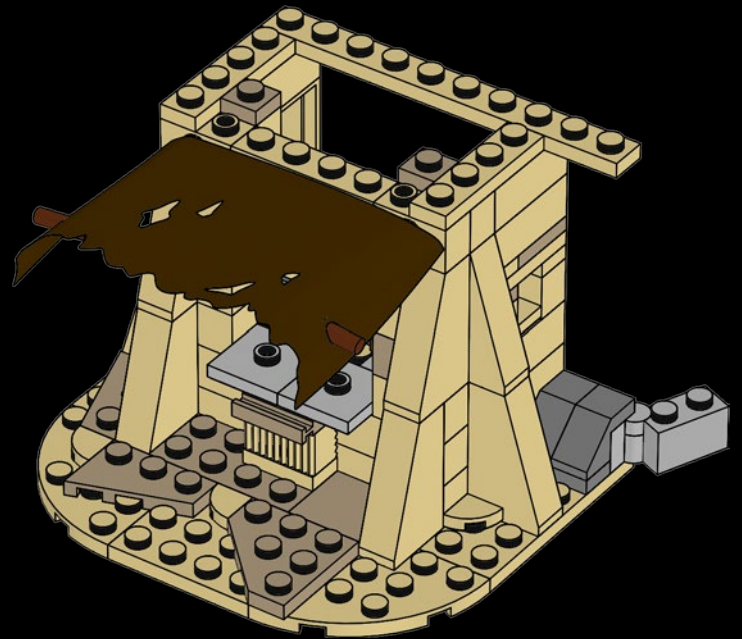

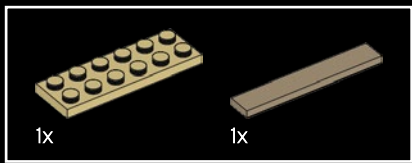

509

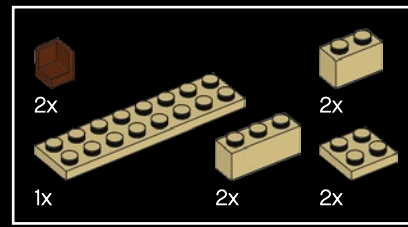
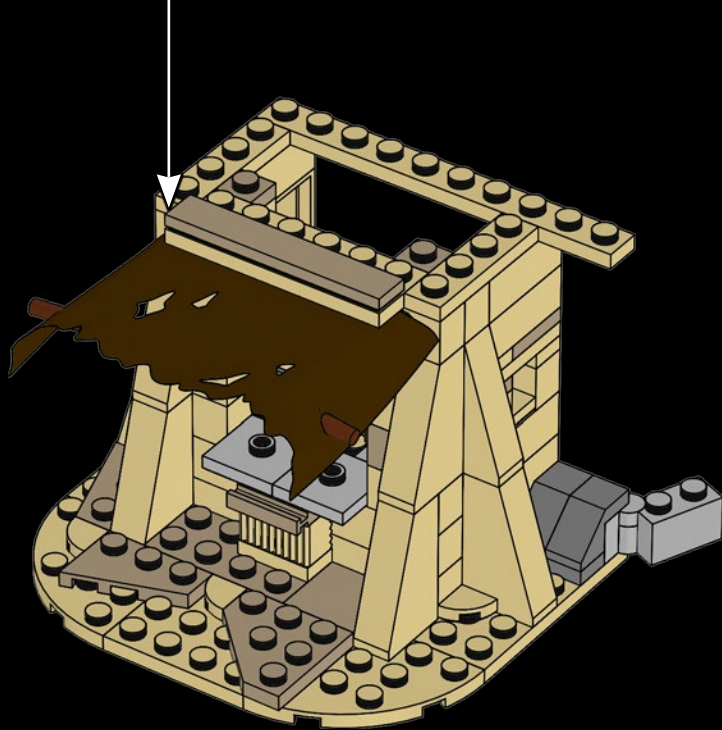
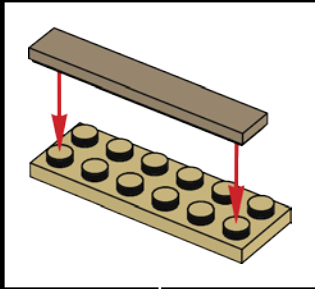

510

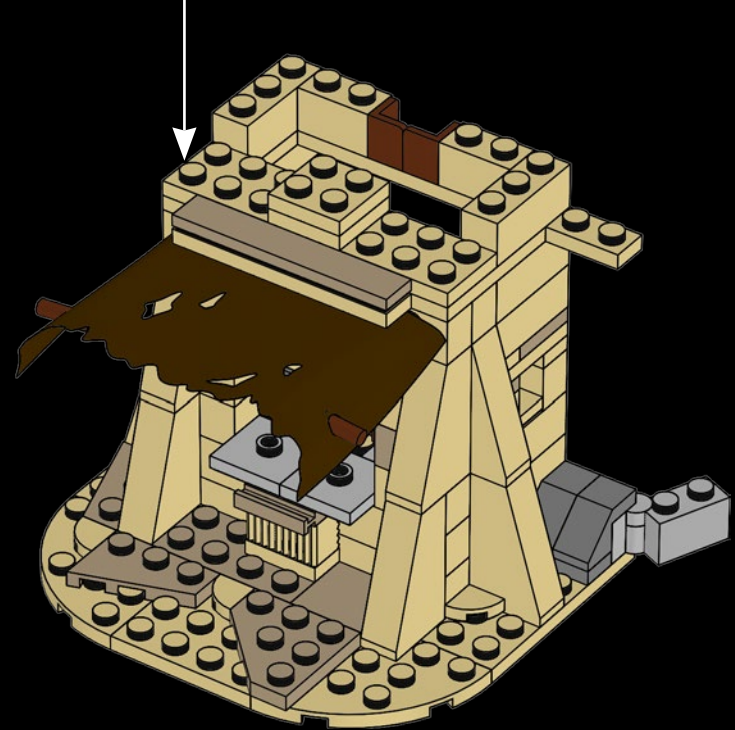
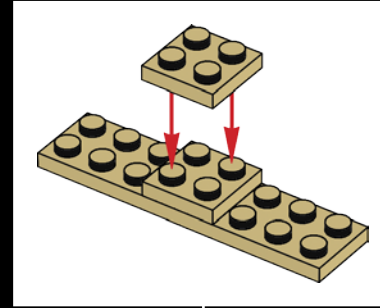

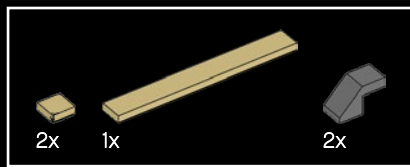

511

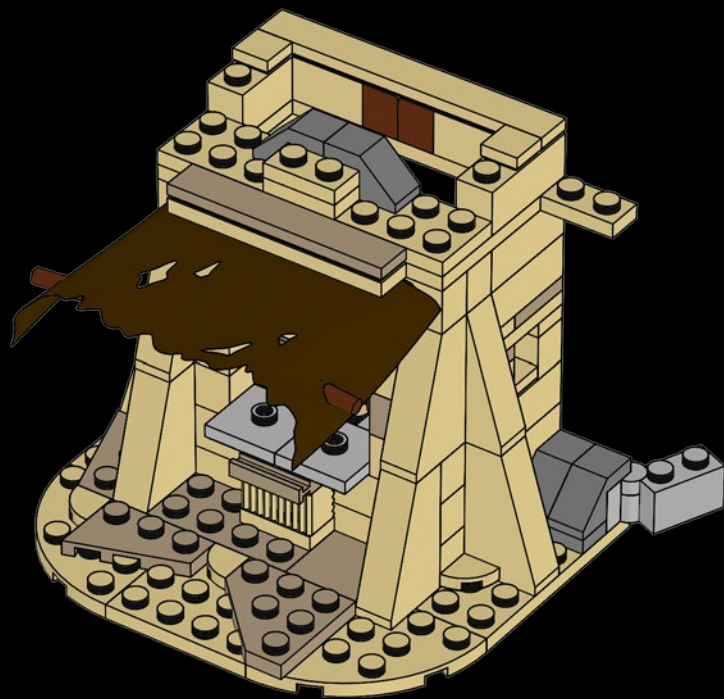

512

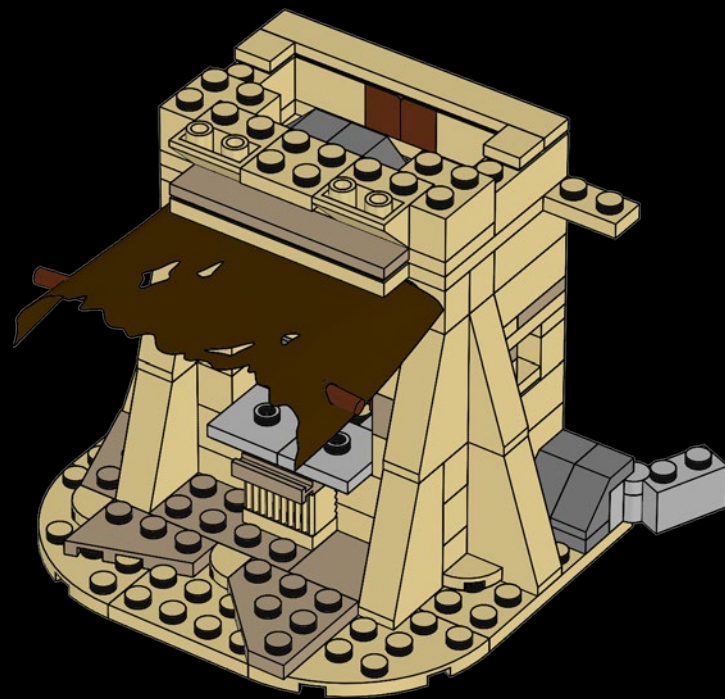



513

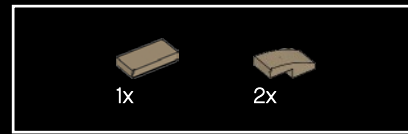
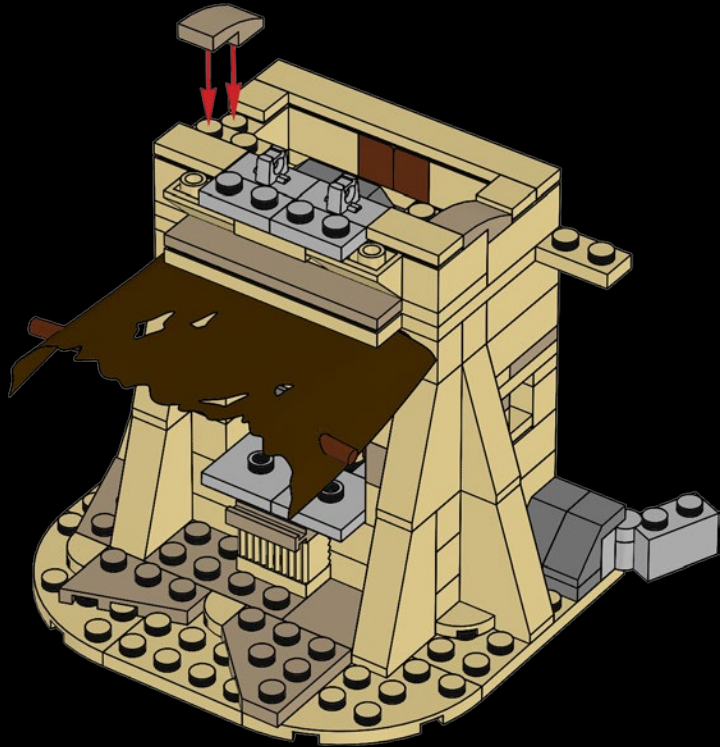

514

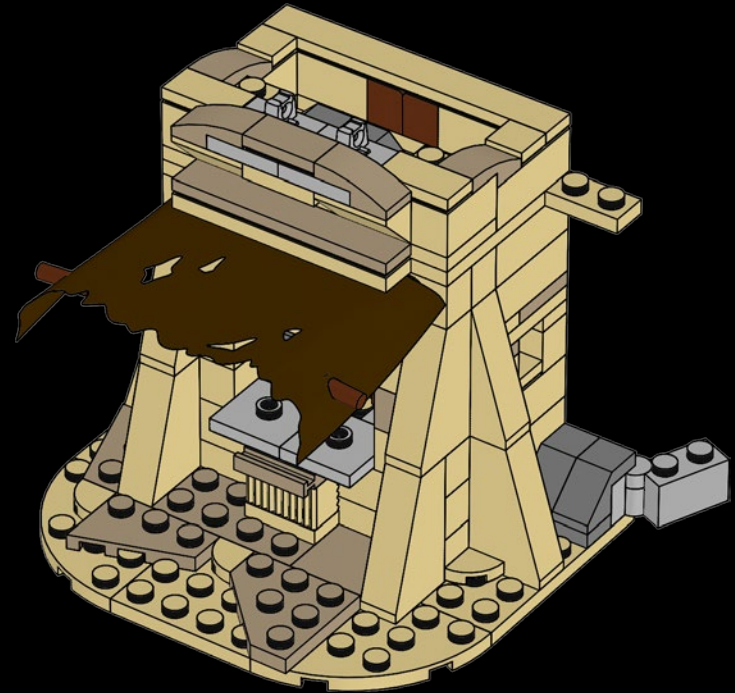

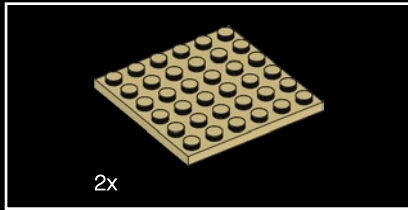
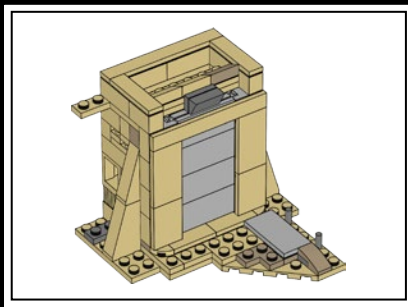

2x

515

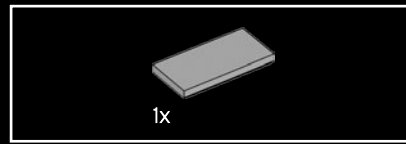
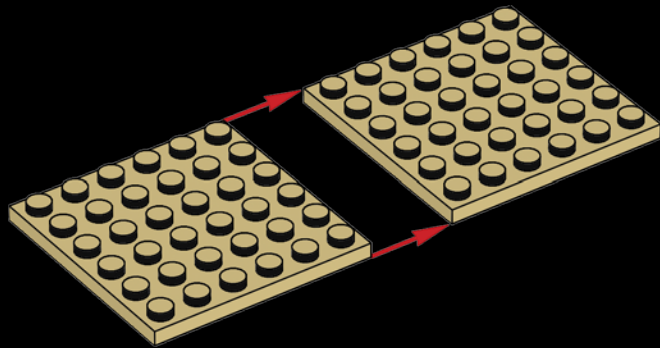

1x

516

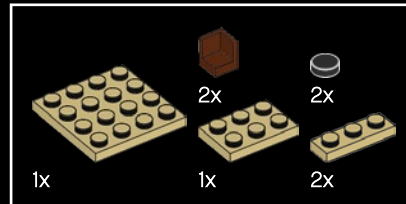
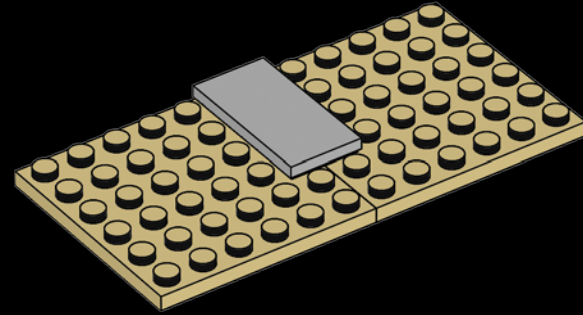

517

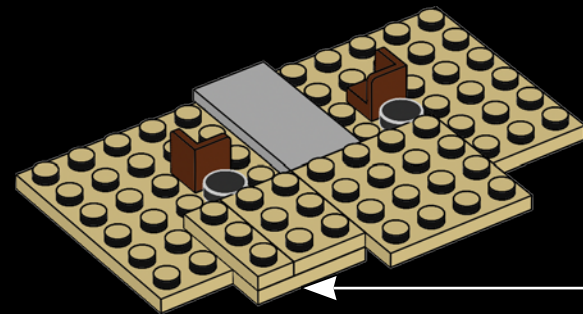
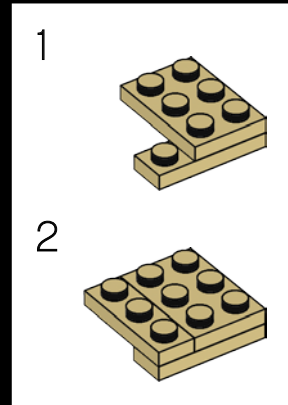

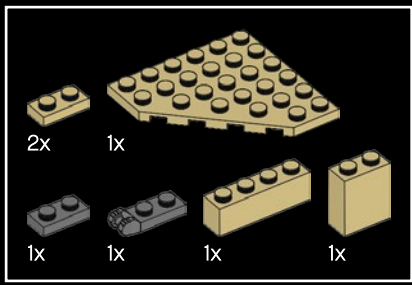

518

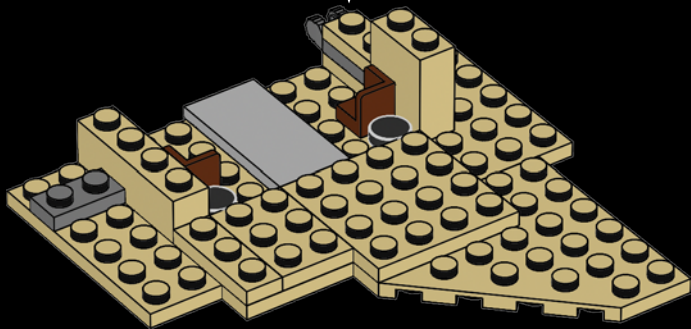
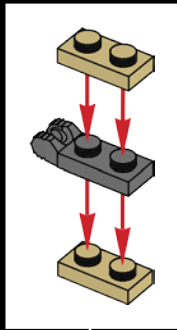

519

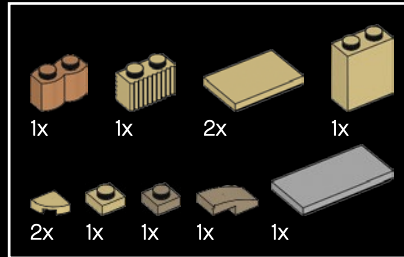
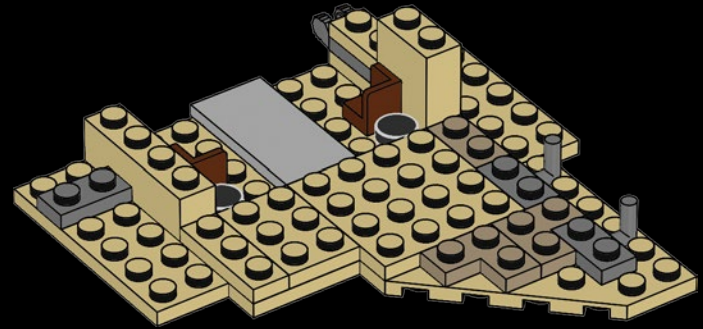

520

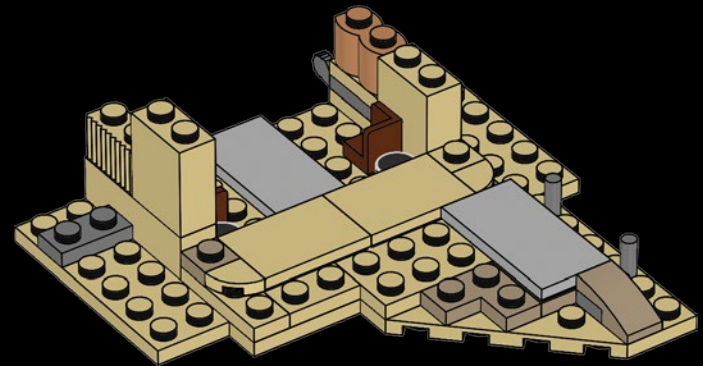

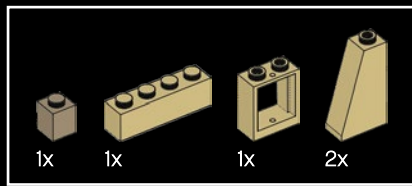

521

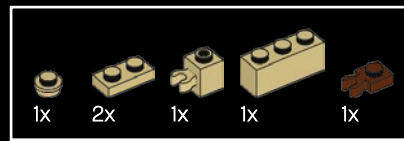
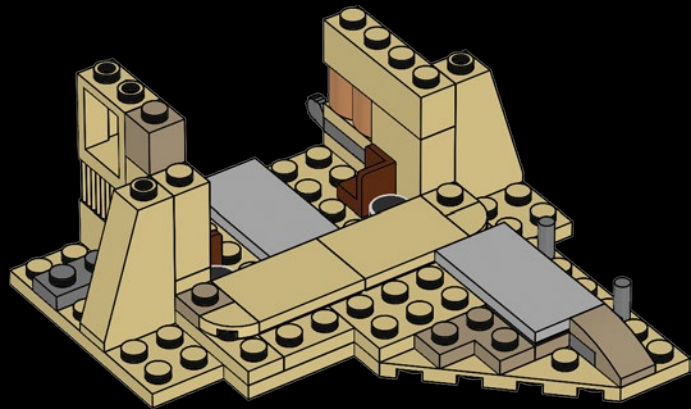

522

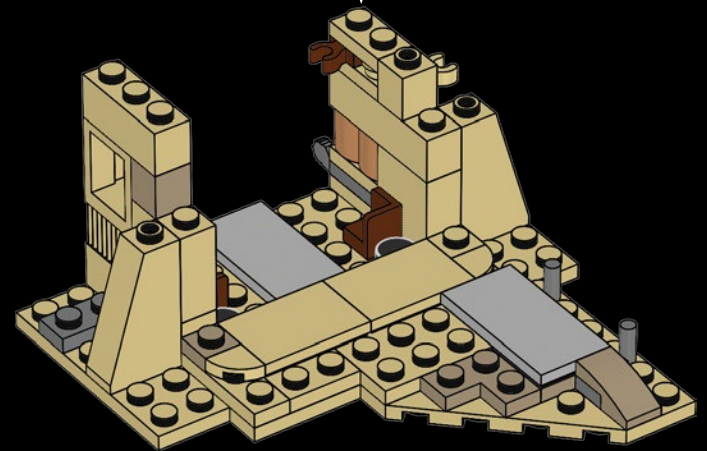
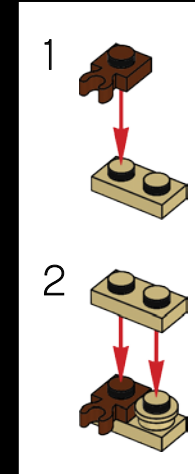

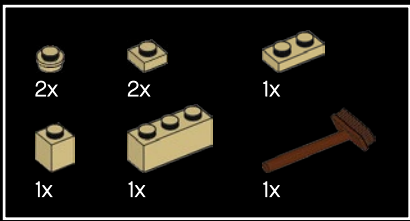

523

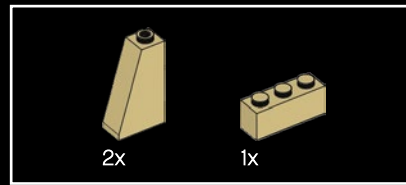
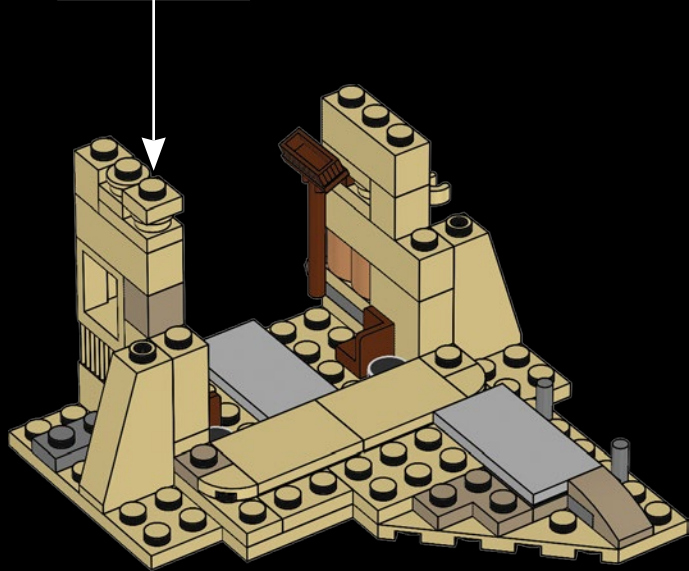
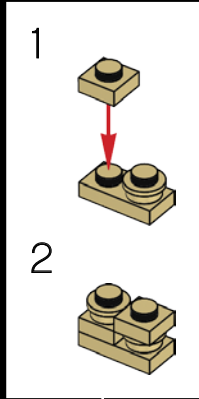

524

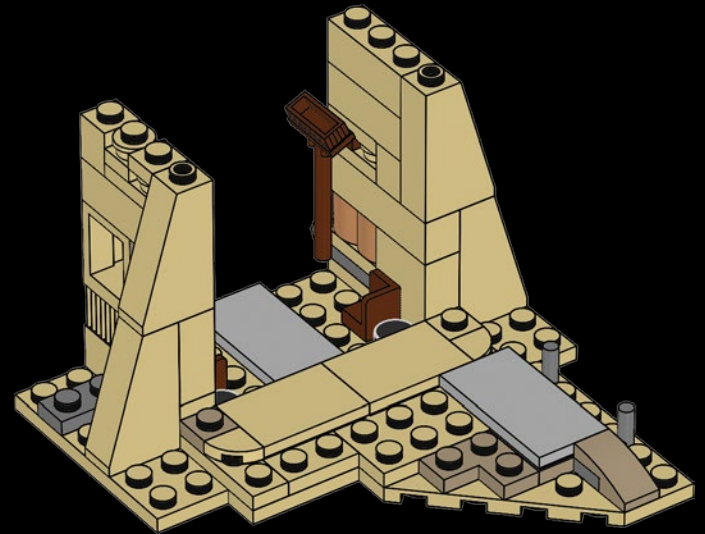

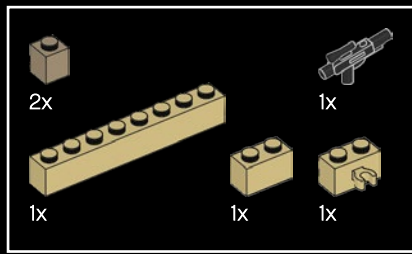

525

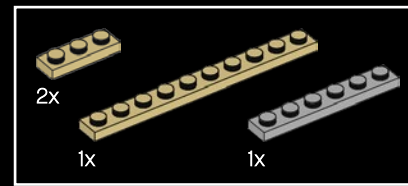
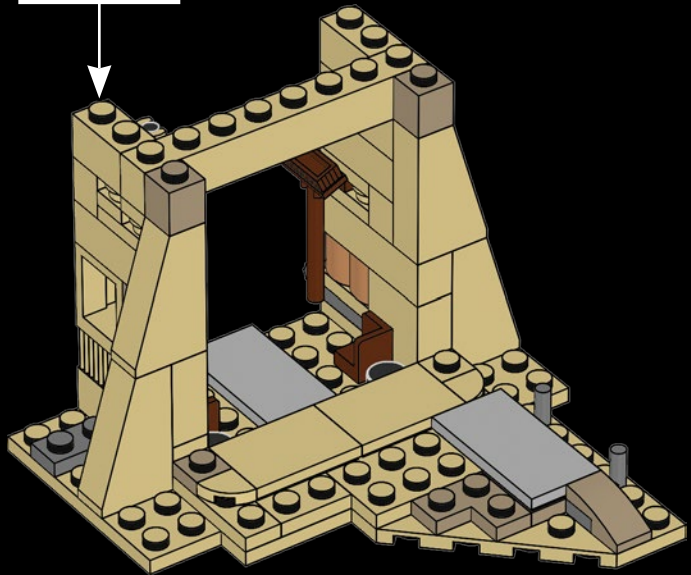

526

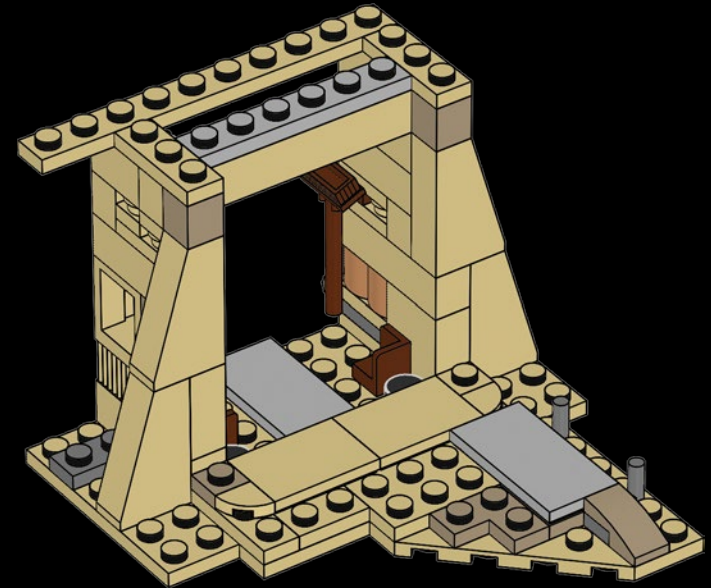

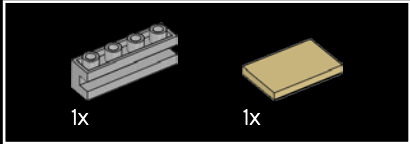
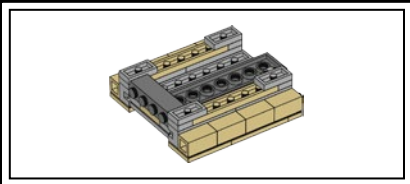

527

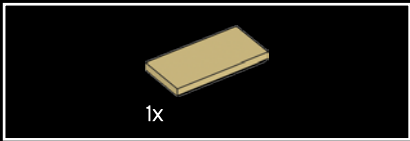
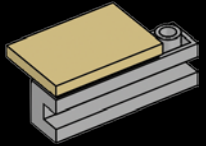

528

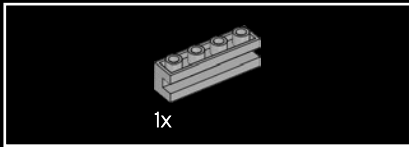
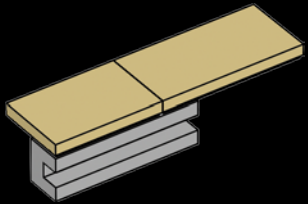

529

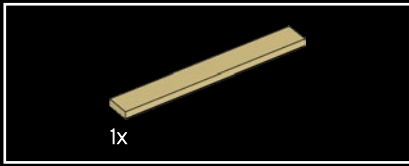
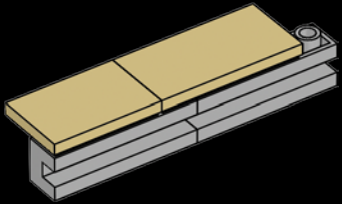

530

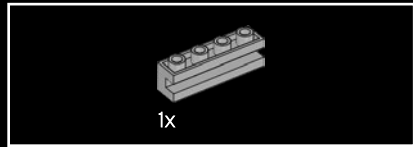
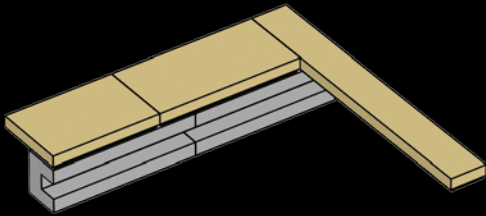

531

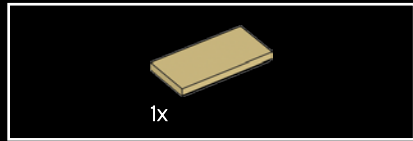
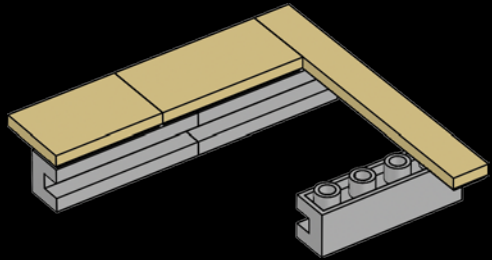

532

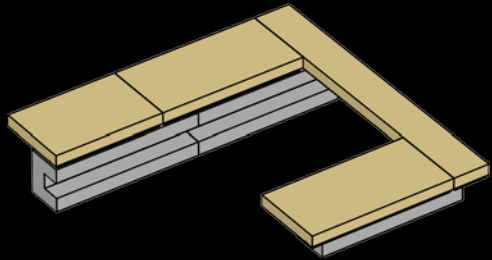

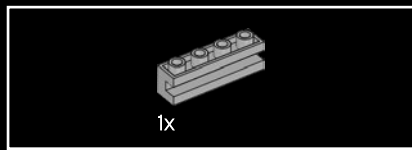

1x

533

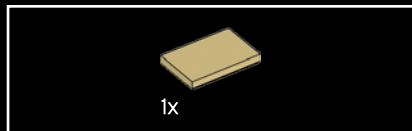
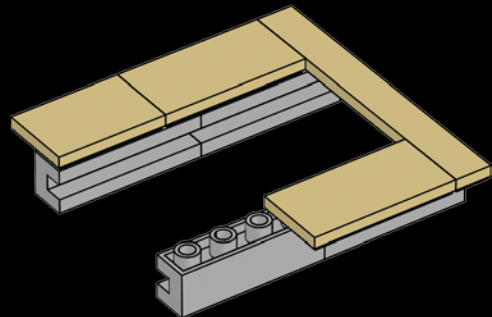

1x

534

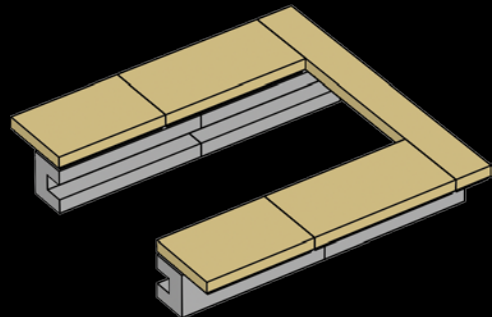

8x

535

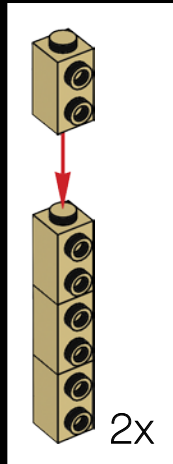

2x

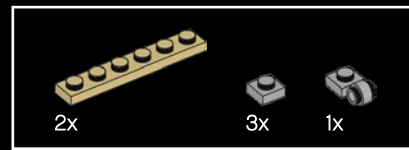
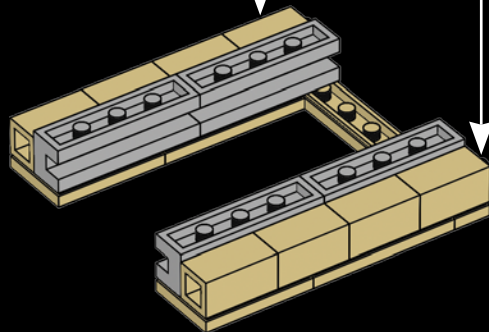

2x

3x

1x

536

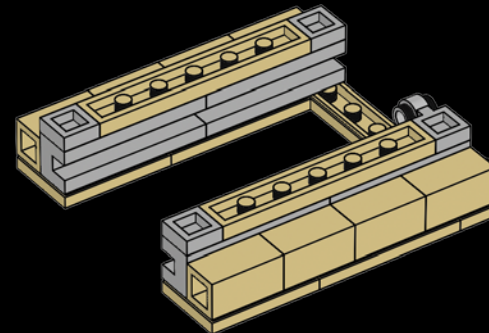

4x

537

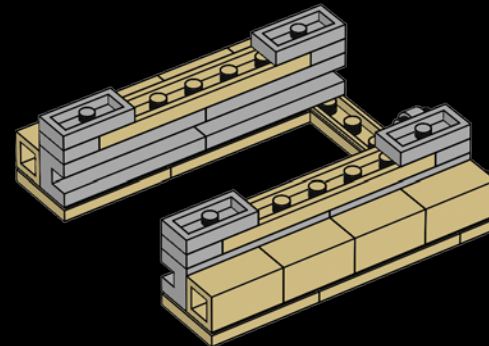

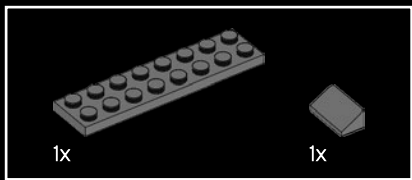

538

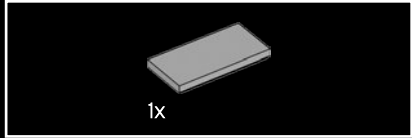
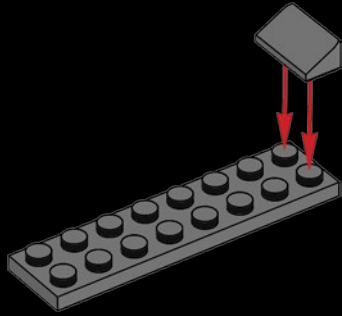

539

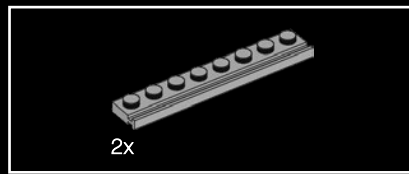
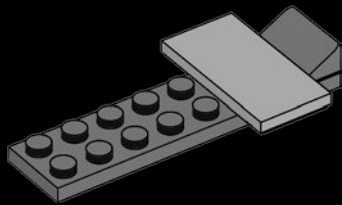

540

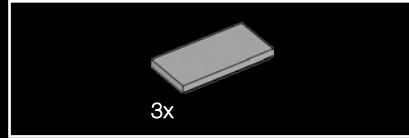
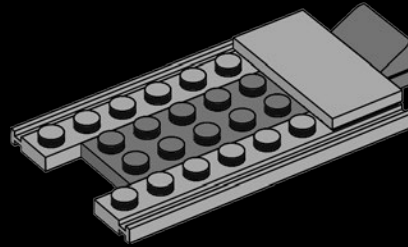

541

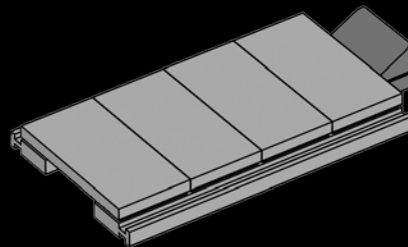

542

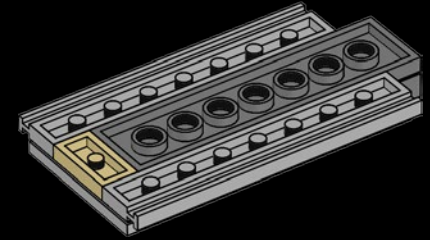

543

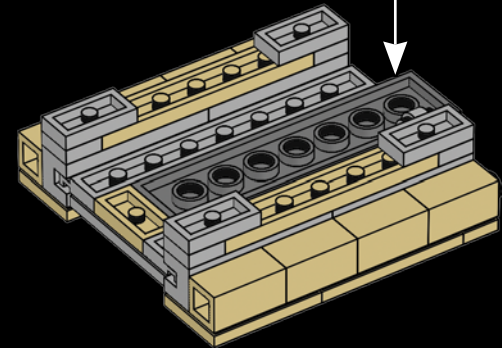

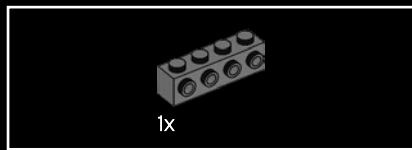

544

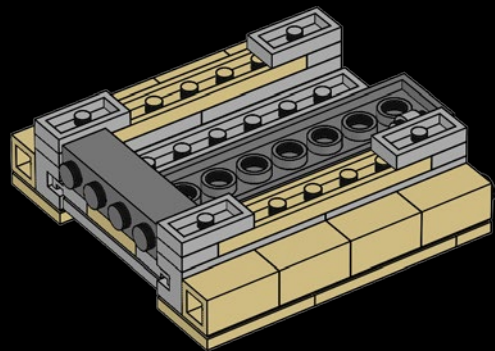

545

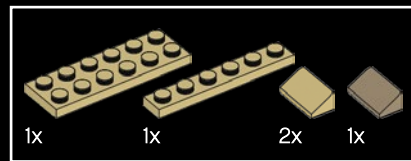
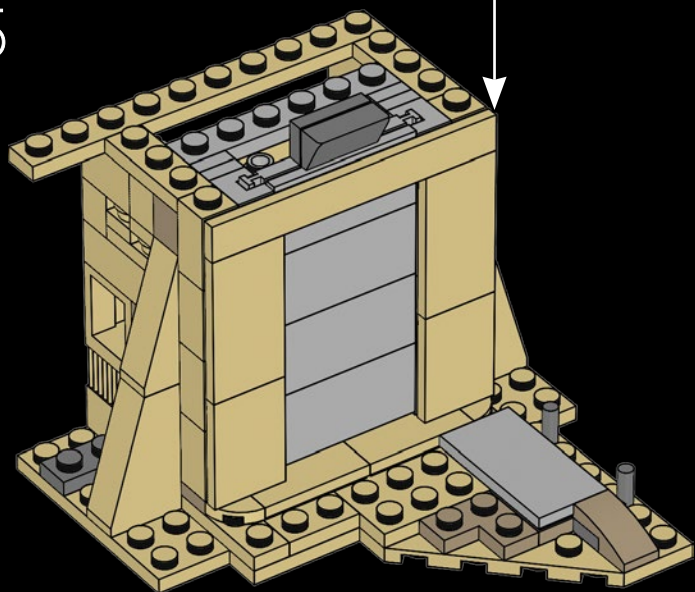

546

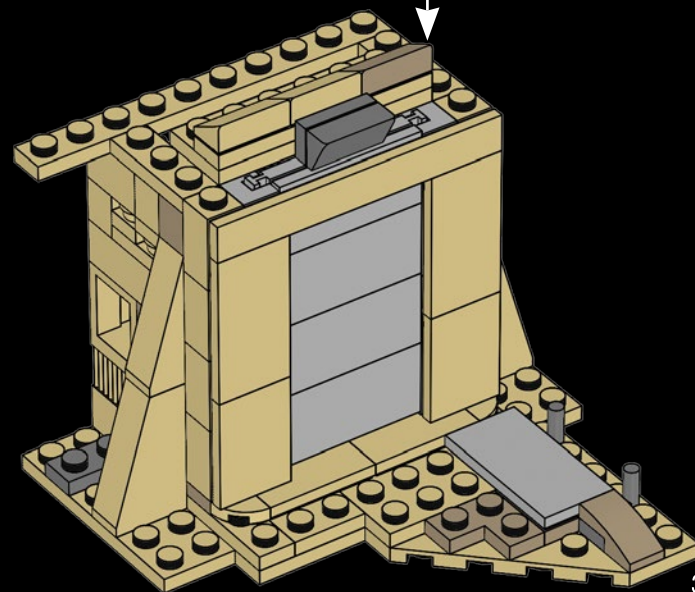
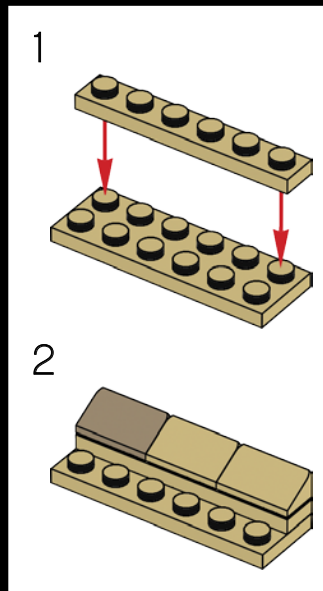

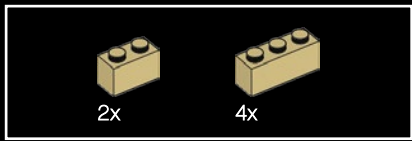

547

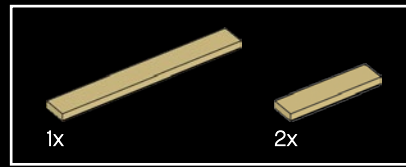
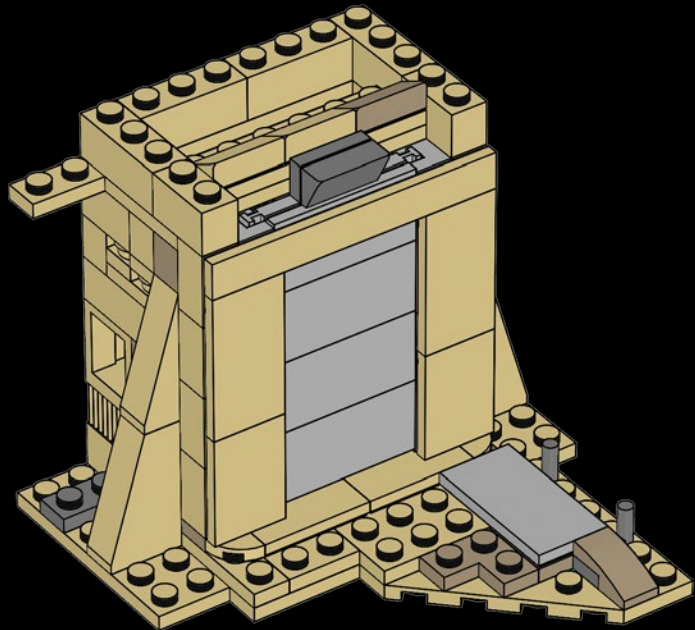

548

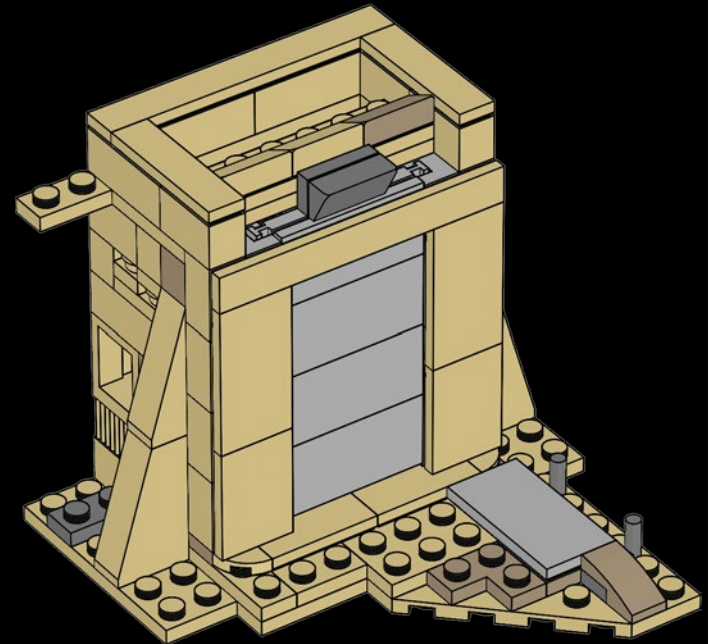

549

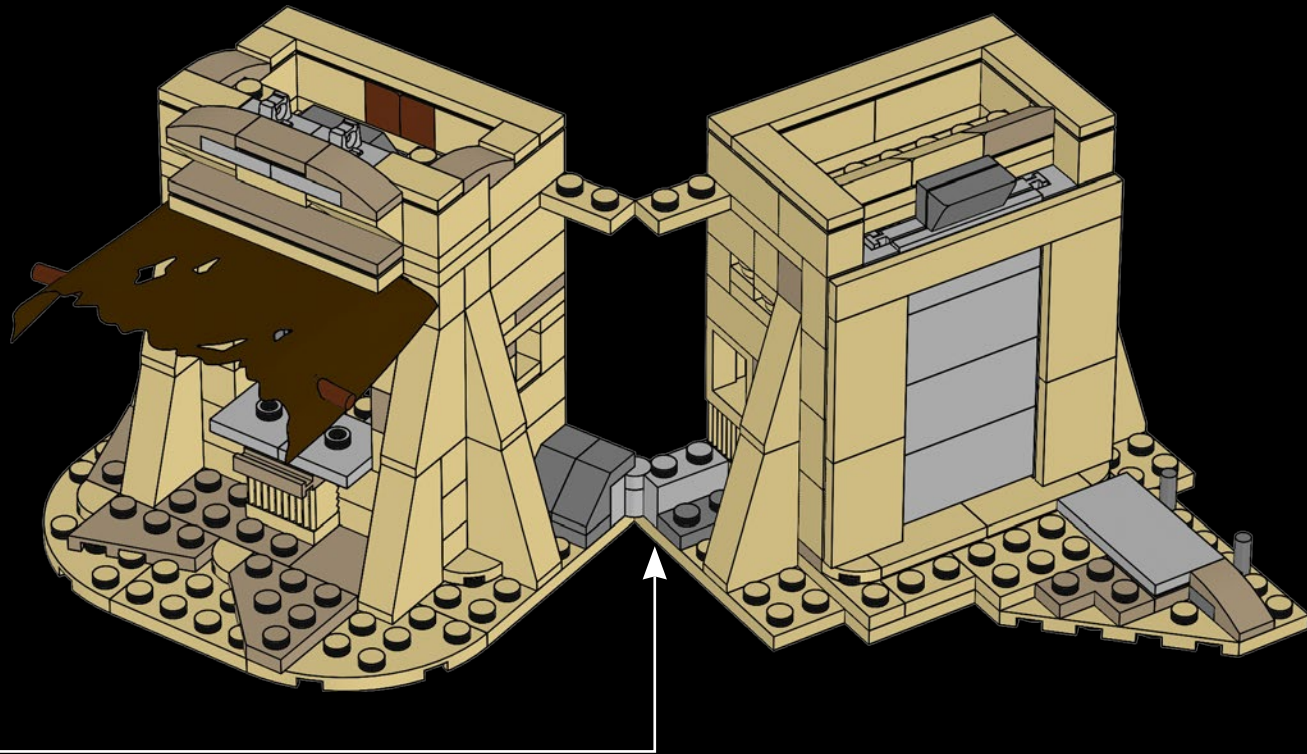



2x

550

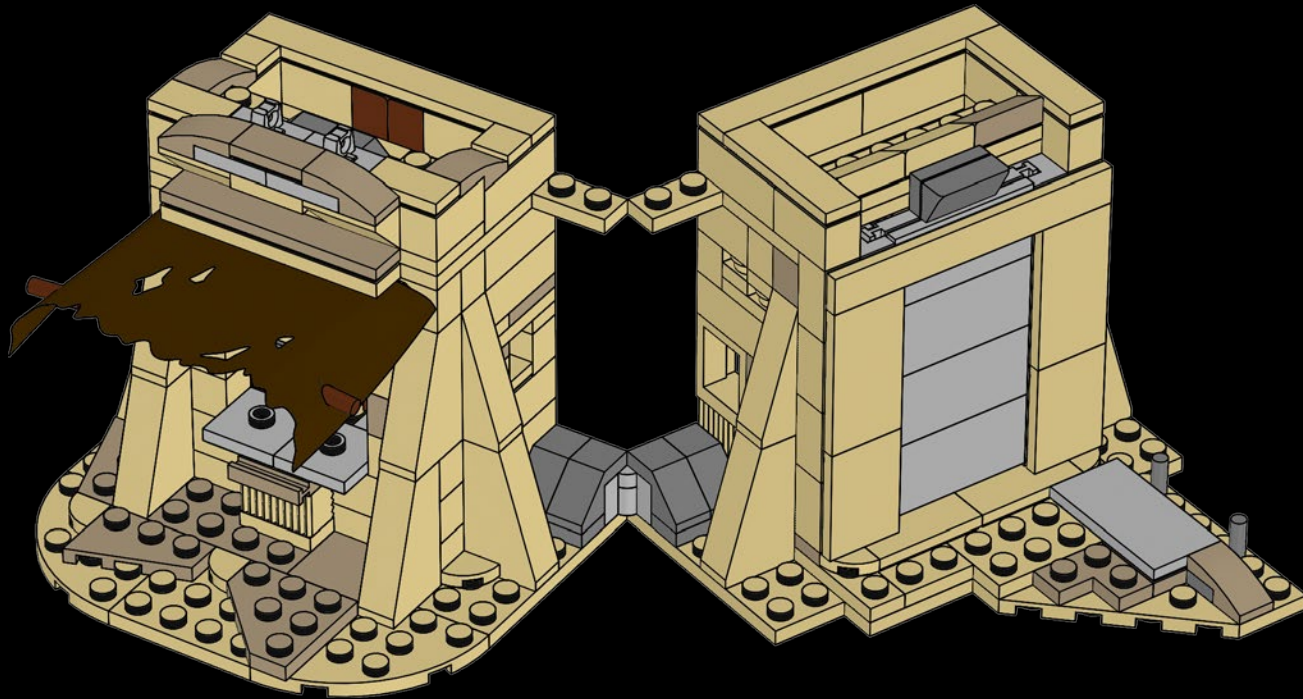

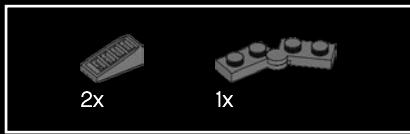

551

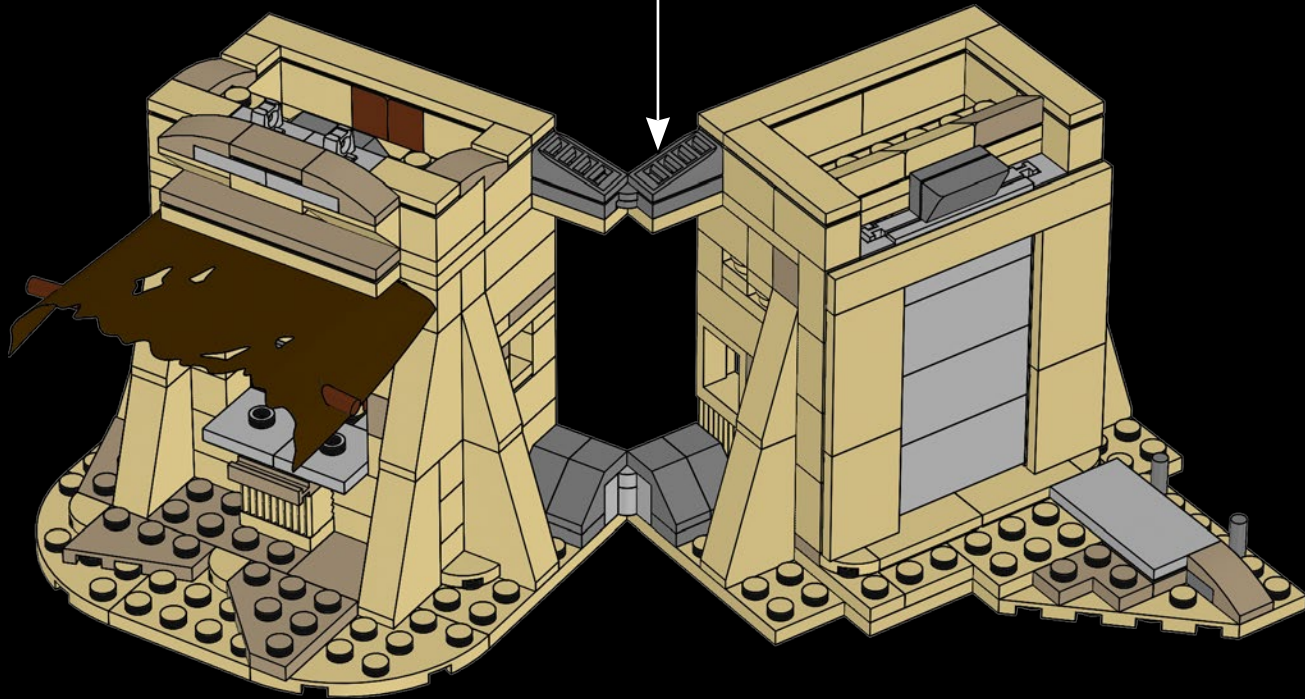
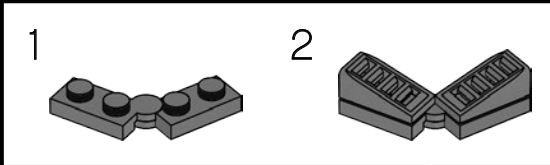

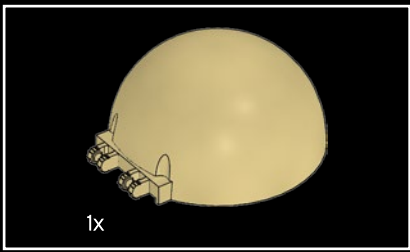

552

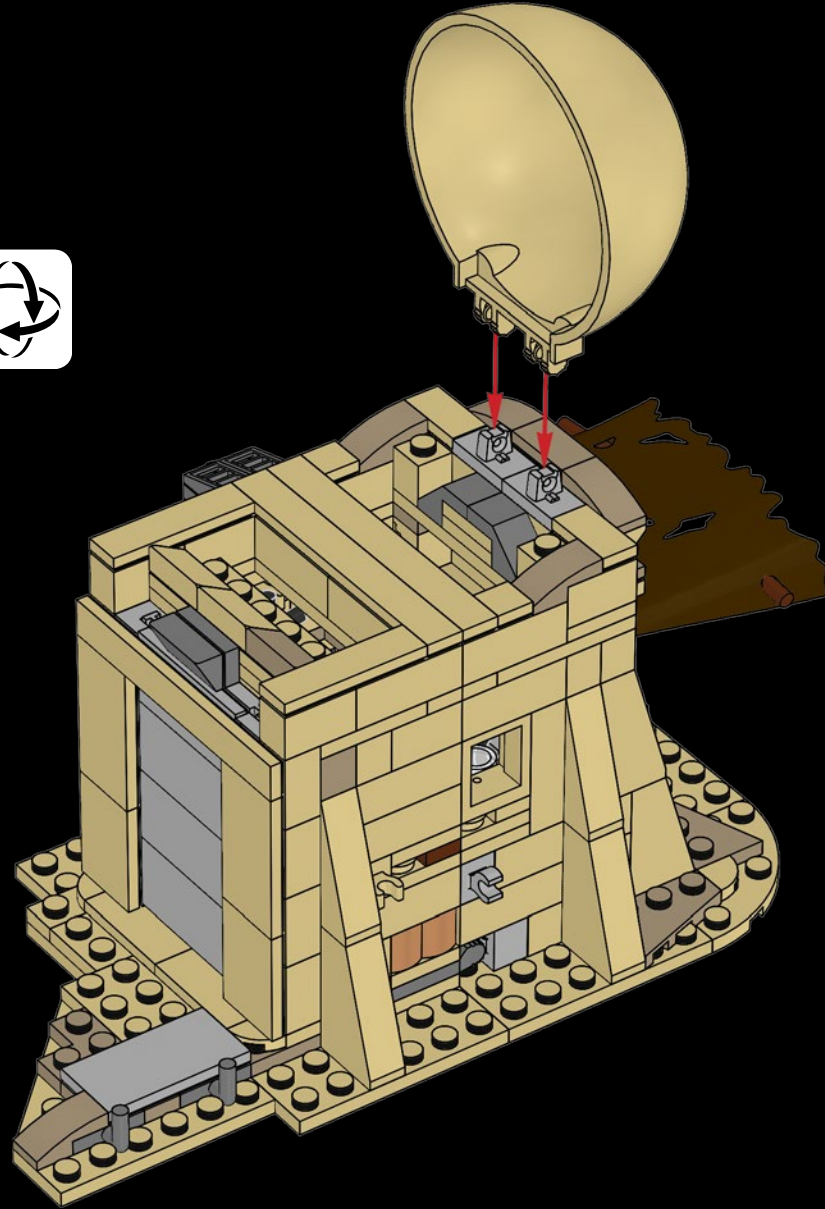

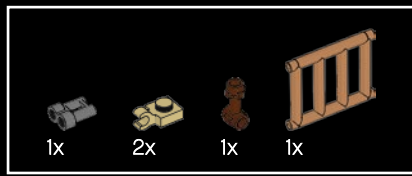

553

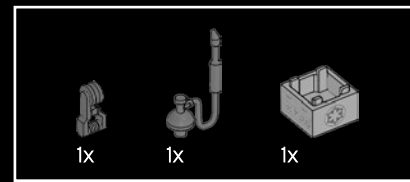
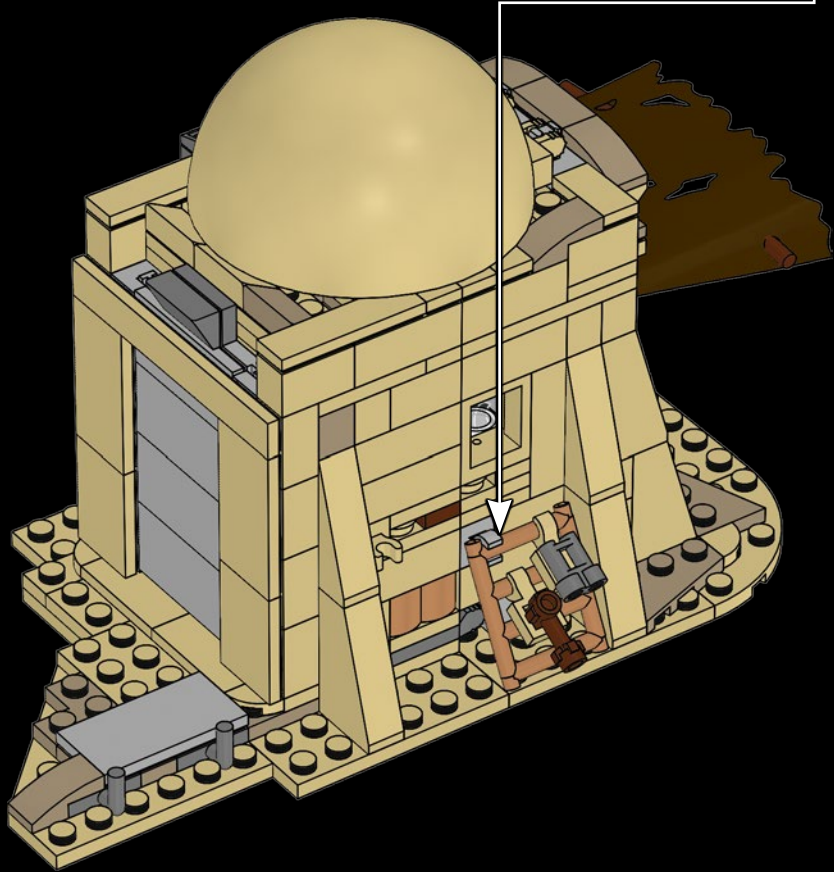
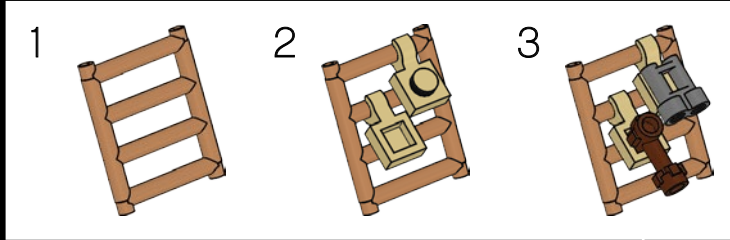

554

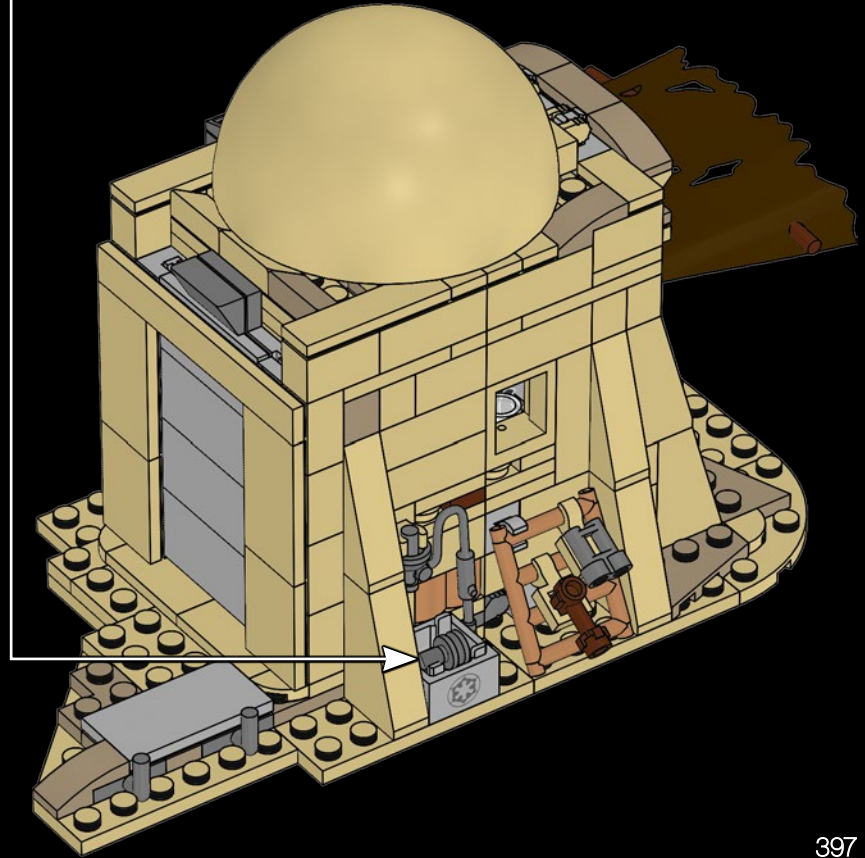

555

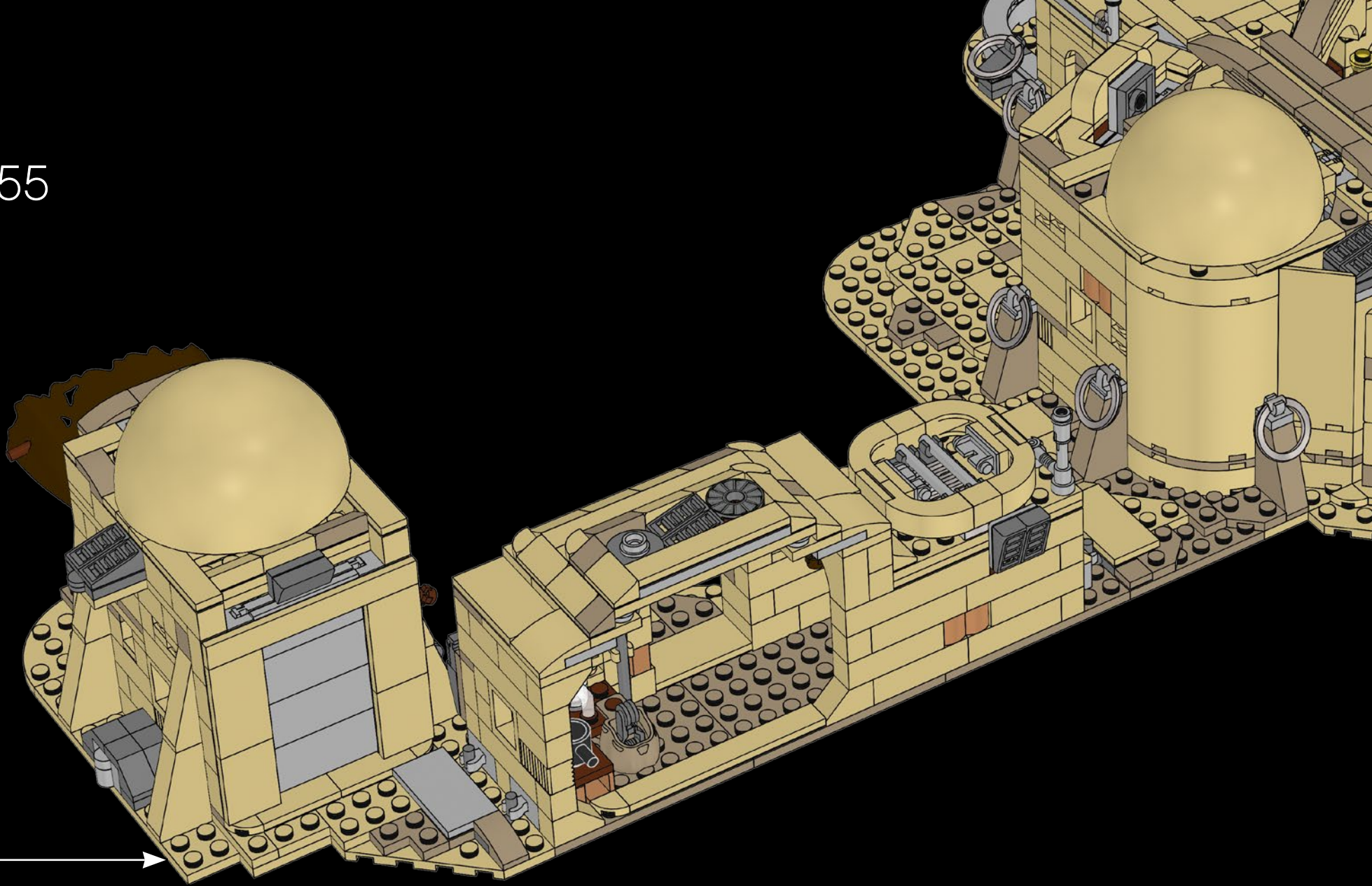

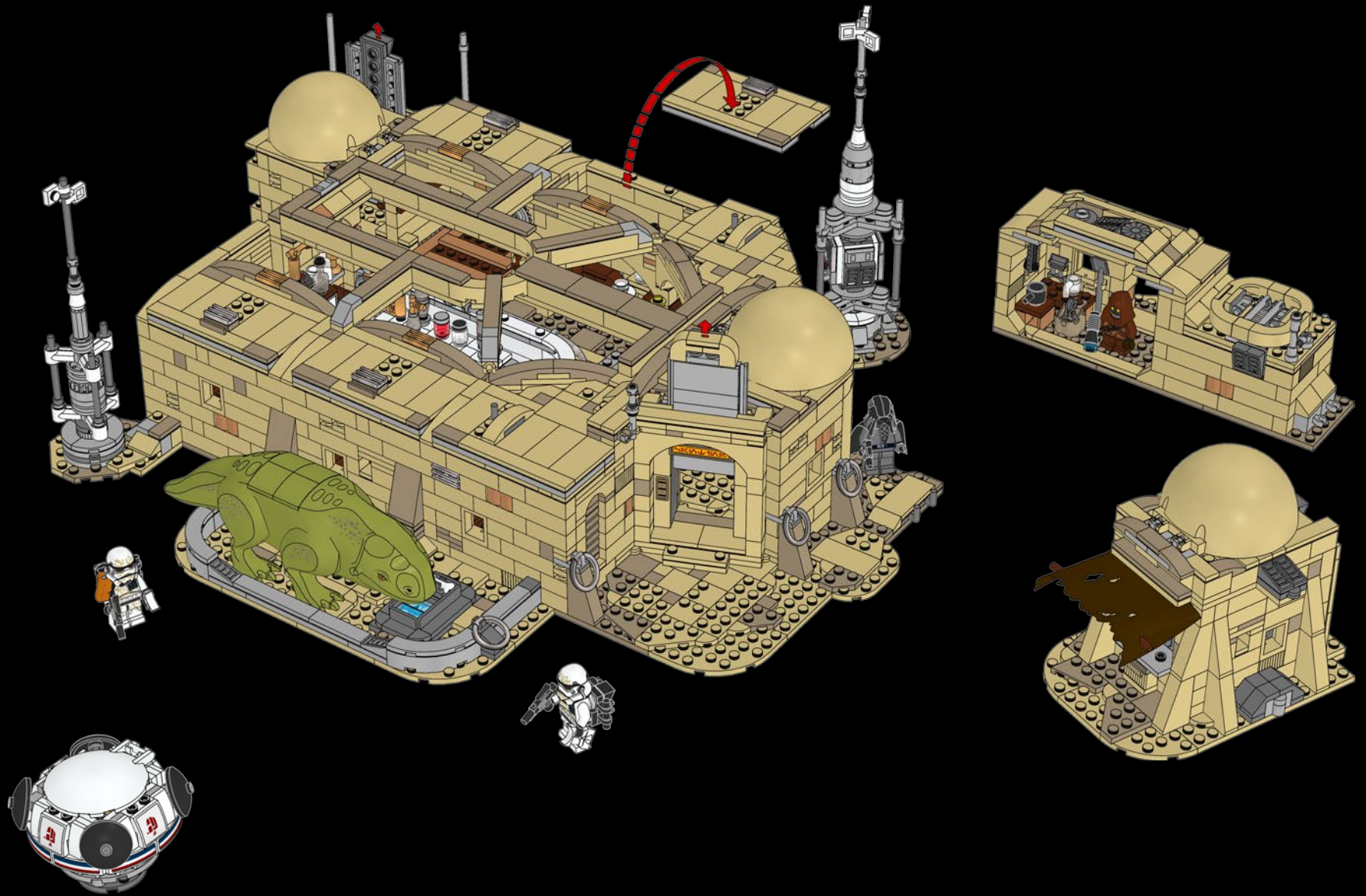

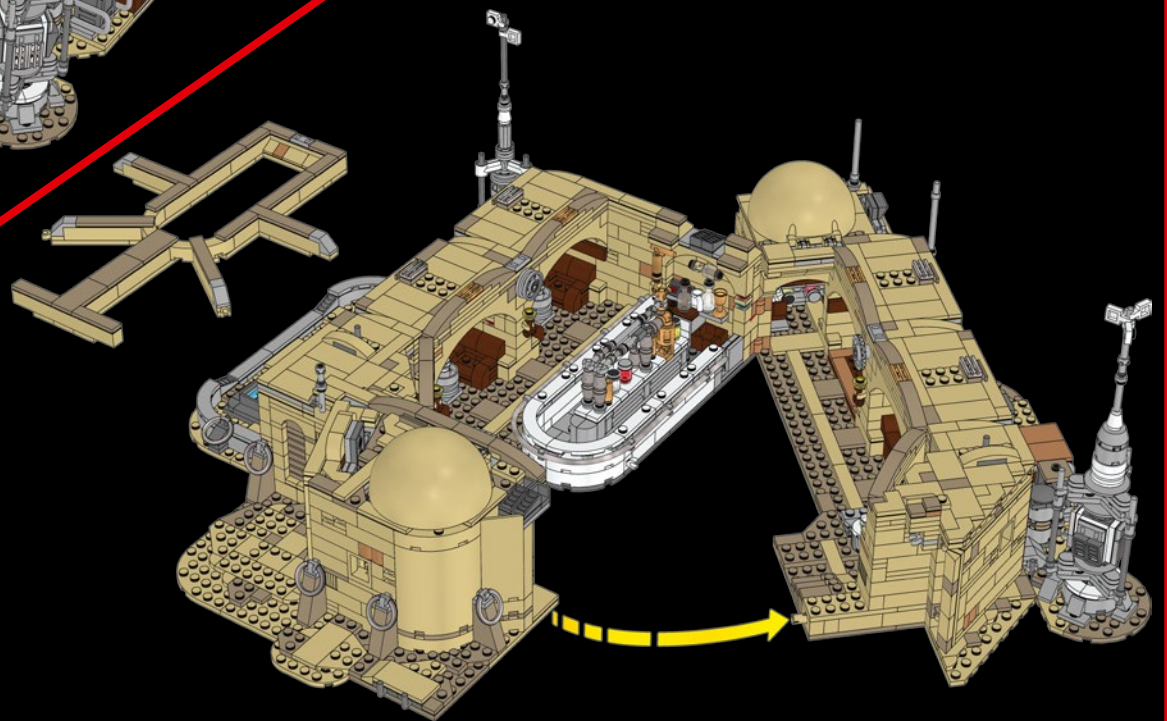
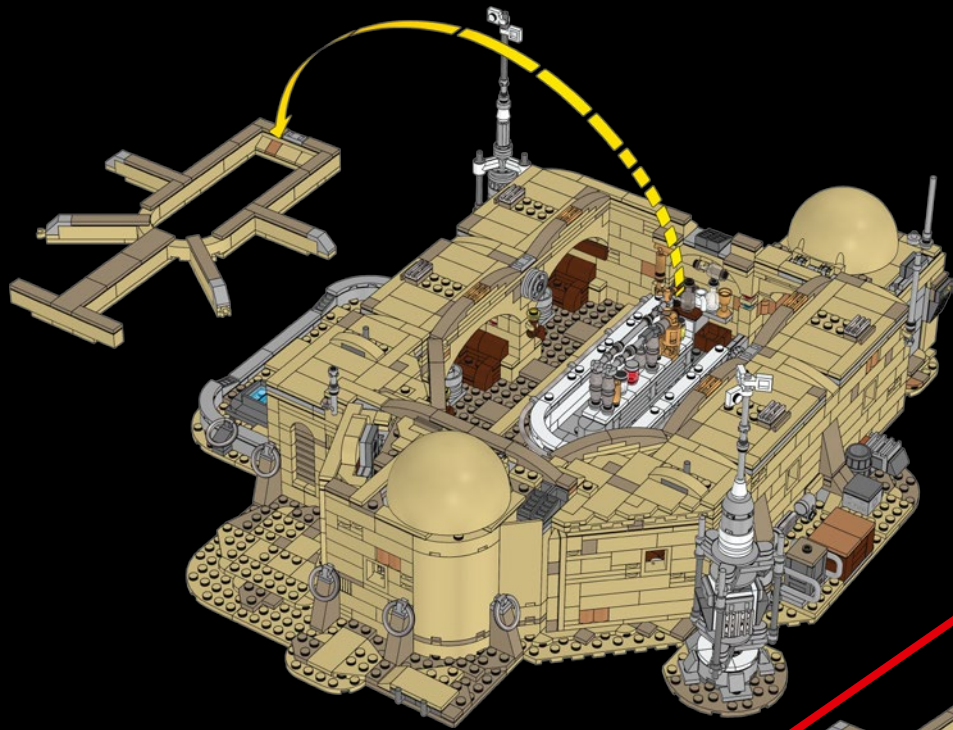

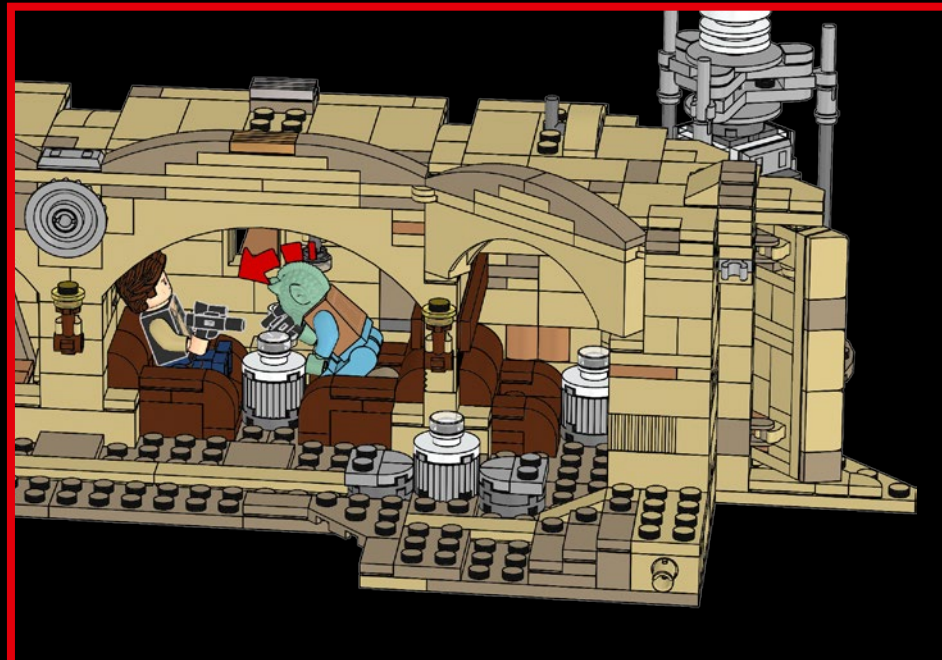
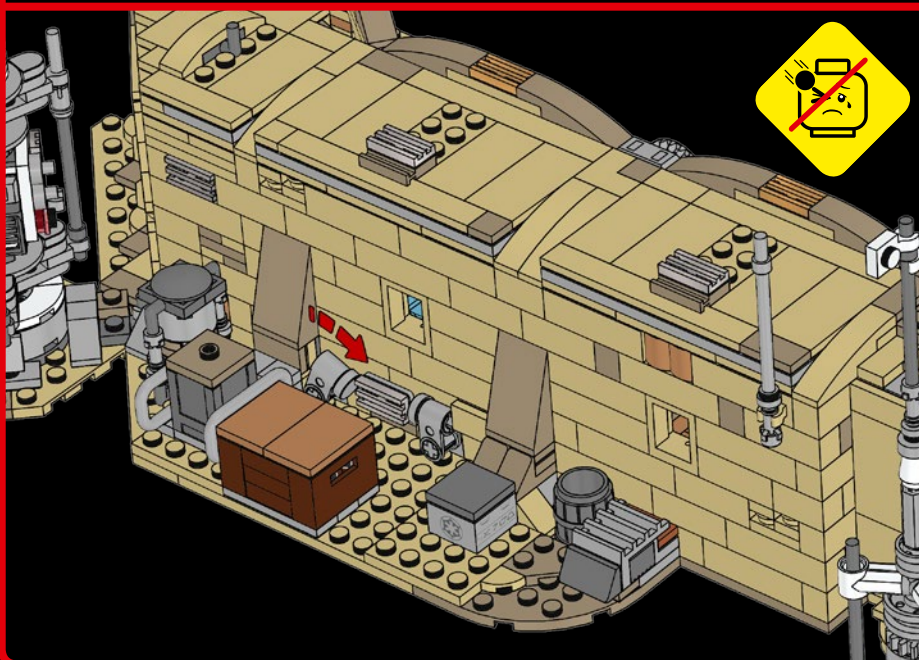
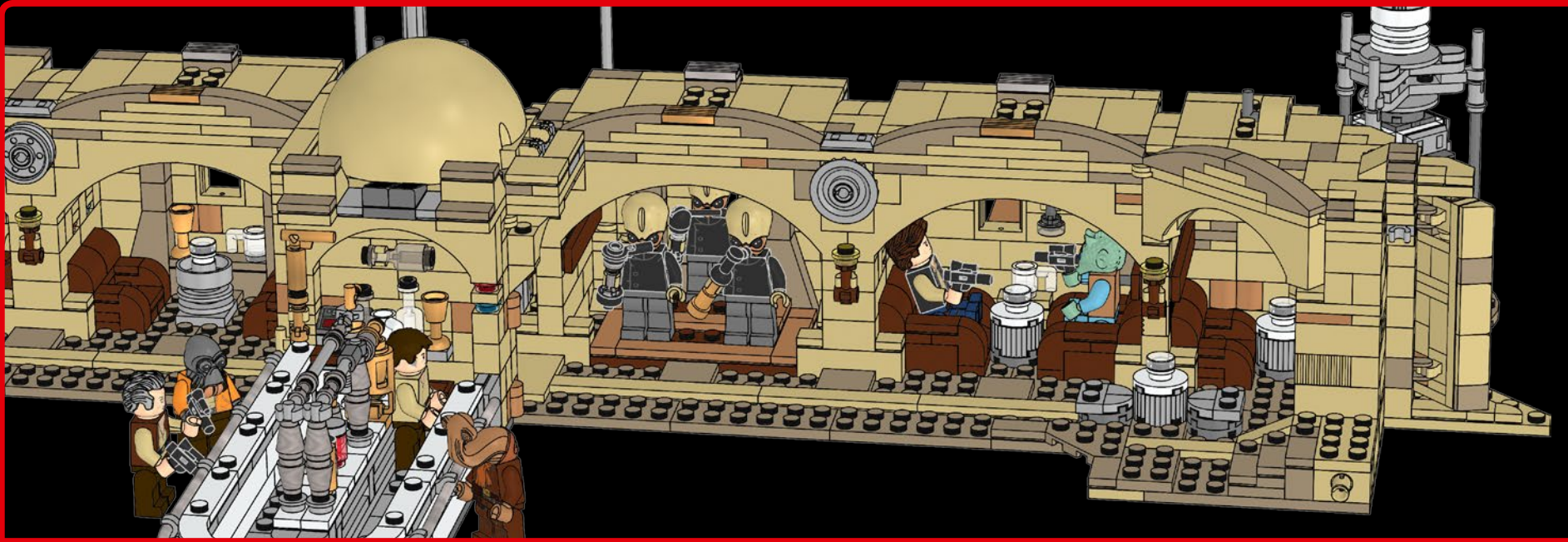

2x 4518400	6x 6332573	1x 4556152	2x 428601	4x 4243812	15x 6232135	7x 6219794	4x 4114322	17x 6175367	21x 4114309	1x 6056230
2x 6186681	2x 6252233	4x 6023099	4x 4558168	2x 6195358	2x 6170568	8x 4205107	12x 6335307	9x 4118790	3x 4114319	6x 4113993
8x 614101	8x 614101	4x 4140583	2x 4520636	4x 4215470	1x 6308161	1x 6021208	4x 6252199	14x 4159739	2x 6210759	6x 4113993
5x 6122729	1x 6055181	4x 4140583	1x 6218822	1x 6250155	1x 6308161	1x 6021208	4x 6252199	14x 4159739	2x 6210759	6x 4113993
4x 307001	4x 6093053	1x 6218822	8x 6210385	2x 4258358	3x 6308153	22x 4114026	10x 6131896	1x 4201062	2x 6106187	1x 4181134
18x 4504369	1x 6069921	8x 6210385	1x 6126046	4x 6158058	1x 4624849	79x 4109995	5x 6211966	1x 4550323	2x 6106187	1x 4181134
2x 302401	2x 6214369	1x 6126046	8x 6047220	4x 302101	2x 6212758	6x 4159196	32x 4121921	21x 4550324	15x 4112982	19x 4544139
4x 6172366	1x 306901	1x 302201	1x 302201	10x 6249091	3x 4520947	2x 6024495	86x 4162465	2x 4666611	1x 4618876	5x 4114324
2x 300501	6x 6051511	4x 6172674	4x 6172674	2x 6045936	4x 6029889	4x 6092587	2x 6058090	8x 6042952	10x 4157277	4x 6313660
2x 4659665	16x 302301	2x 242001	2x 242001	2x 6045936	2x 6228984	2x 4159279	7x 4114084	34x 4113233	20x 4124067	5x 4159774
2x 6320310	1x 300401	1x 6092256	1x 6092256	2x 4515359	10x 6136390	14x 4578107	16x 4114077	7x 6257600	6x 4243824	1x 6123812
2x 4600294	12x 6034044	3x 6046979	3x 6046979	2x 4583297	1x 6177890	6x 4273526	9x 6265572	117x 4113916	6x 6006805	2x 4113988
5x 4538353	2x 6172927	4x 362301	4x 362301	2x 302001	2x 4666579	95x 4113917	21x 4124455	5x 4208072	4x 4570516	6x 4125217
2x 4179875	2x 4121932	1x 6195371	1x 6195371	2x 6252516	28x 4624086	6x 4118866	6x 4118866	12x 6102772	2x 4570516	2x 4113988
2x 4179874	2x 6278499	4x 362201	4x 362201	1x 663601	13x 4655900	3x 6173057	3x 6173057	39x 6122047	4x 6034852	2x 4113988
5x 4547489	3x 6097637	8x 4249112	8x 4249112	1x 663601	3x 6057517	10x 4114306	10x 4114306	1x 6056277	4x 6034852	6x 4125217

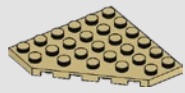

3x
6036485



3x
6056484



3x
4143409

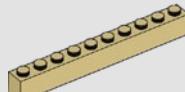

1x
4166138

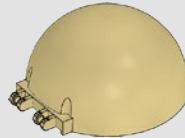

3x
6314982

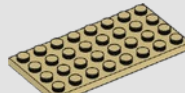

5x
4509897



1x
4249019

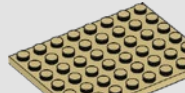

3x
6070501



2x
6156462

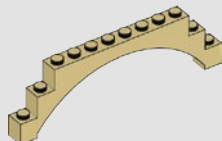

5x
6246845

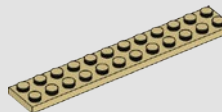

3x
6093864

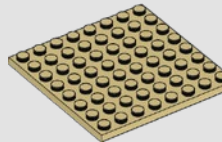

1x
4624223

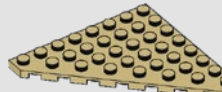

2x
4626948

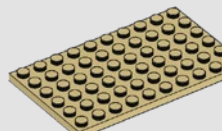

1x
4624185



2x
302321



2x
302221



1x
300221

1x
6036408



3x
4143005



1x
302223



2x
300323



1x
366623



2x
300424



1x
302124



2x
4598897



1x
6033301



1x
4161332

1x
6196548



8x
6172383



2x
4504382



2x
6335388



2x
4558954



6x
4609050



1x
6003301



1x
4161332



1x
6196548



1x
4160869

2x
4548180



1x
9339



1x
434926



1x
6020193



2x
4140588



3x
4498713



1x
368026



2x
242026



2x
235726



4x
4180087

1x
4558170



1x
371026



1x
300126



1x
6058118



2x
6106296



1x
370726



1x
373726



3x
383226



1x
6308112



1x
6316560

1x
6295081

8

10

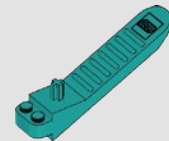

1x
6254100



6x
6274744



3x
6247372

1x
6262645



6x
4183133



2x
6174945



25x
6055172



28x
4549436



5x
6040126



24x
6001824

2x
6002843



4x
6135609



2x
6170313



6x
6101254



6x
6093064



24x
4528604



3x
4646577



43x
4496699



3x
4521914



11x
6228921

1x
6146234



1x
6135610



1x
6002849



11x
4507045



2x
6047415



1x
6126075



3x
4550168



4x
6000852



3x
6132768



7x
6015452

11x
6035540

3x
6001822

5x
6257599

5x
6175927

14x
6045943



6x 6038637
 3x 6164288
 2x 4267874
 1x 6015424
 8x 4507047
 1x 4570451
 1x 4550329
 1x 6146989
 1x 4246957
 1x 6022043
 6x 4251796

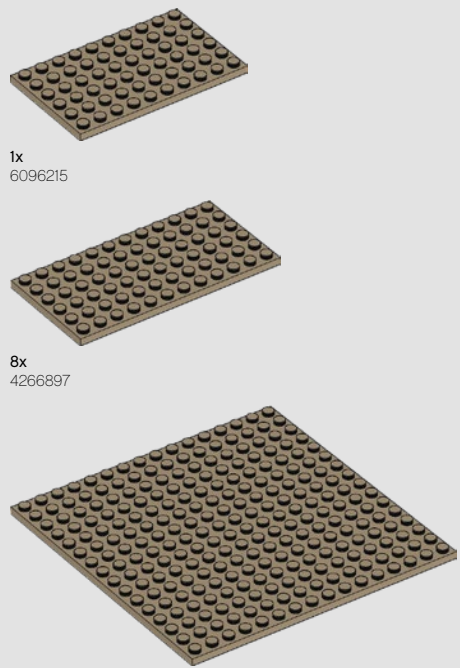

1x 6096215
 8x 4266897

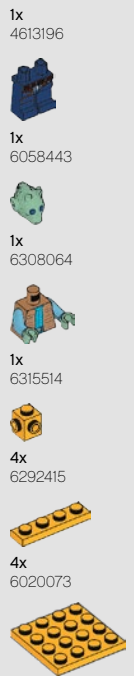

1x 4613196
 1x 6058443
 1x 6308064
 1x 6315514
 4x 6292415
 4x 6020073
 4x 6093272

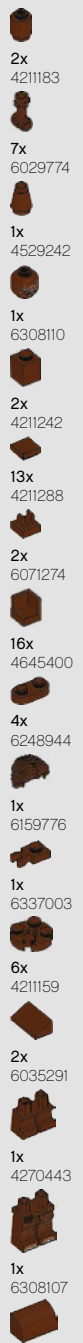

2x 4211183
 7x 6029774
 1x 4529242
 1x 6308110
 2x 4211242
 13x 4211288
 2x 6071274
 16x 4645400
 4x 6248944
 1x 6159776
 1x 6337003
 6x 4211159
 2x 6035291
 1x 4270443
 1x 6308107
 20x 6311210

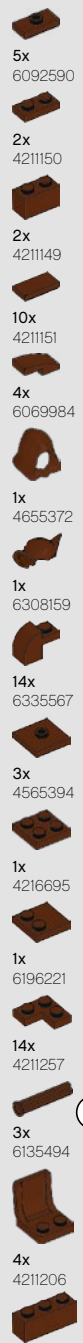

5x 6092590
 2x 4211150
 2x 4211149
 10x 4211151
 4x 6069984
 1x 4655372
 1x 6308159
 14x 6335567
 3x 4565394
 1x 4216695
 1x 6196221
 14x 4211257
 3x 6135494
 4x 4211206
 2x 4211220

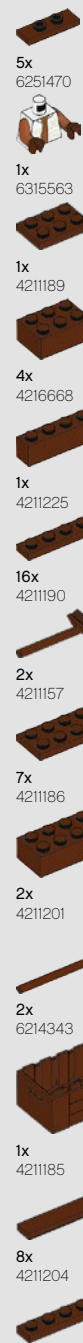

5x 6251470
 1x 6315563
 1x 4211189
 4x 4216668
 1x 4211225
 16x 4211190
 2x 4211157
 7x 4211186
 2x 4211201
 2x 6214343
 1x 4211185
 8x 4211204
 2x 4221590

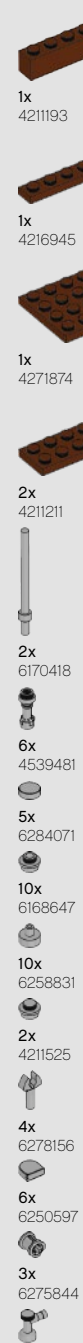

1x 4211193
 1x 4216945
 1x 4271874
 2x 4211211
 2x 6170418
 6x 4539481
 5x 6284071
 10x 6168647
 10x 6258831
 2x 4211525
 4x 6278156
 6x 6250597
 3x 6275844
 4x 4211503



7x 4211483
 2x 6308012
 10x 6176433
 14x 4211399
 5x 4211415
 4x 4211476
 3x 4521921
 1x 4211389
 6x 6225242
 2x 4211535
 5x 6248078
 2x 6320306
 2x 4211758
 1x 6123037
 4x 4211508
 3x 6281998
 1x 6163477



6x 6248890
 1x 6227897
 11x 6296894
 2x 6225246
 2x 4533772
 2x 4514195
 2x 6261375
 1x 4278273
 2x 6028324
 1x 4568637
 7x 6450645
 1x 6092956
 2x 4211807
 3x 4550325
 1x 4540203
 3x 4211526
 3x 6326078



2x 4640536
 1x 4512360
 4x 6043656
 2x 4211470
 9x 6134378
 8x 6313114
 1x 4211357
 4x 6320297
 1x 6146223
 19x 4211398
 6x 4211414
 2x 6227184
 11x 6213378
 1x 6206249
 2x 6092111
 2x 4211541

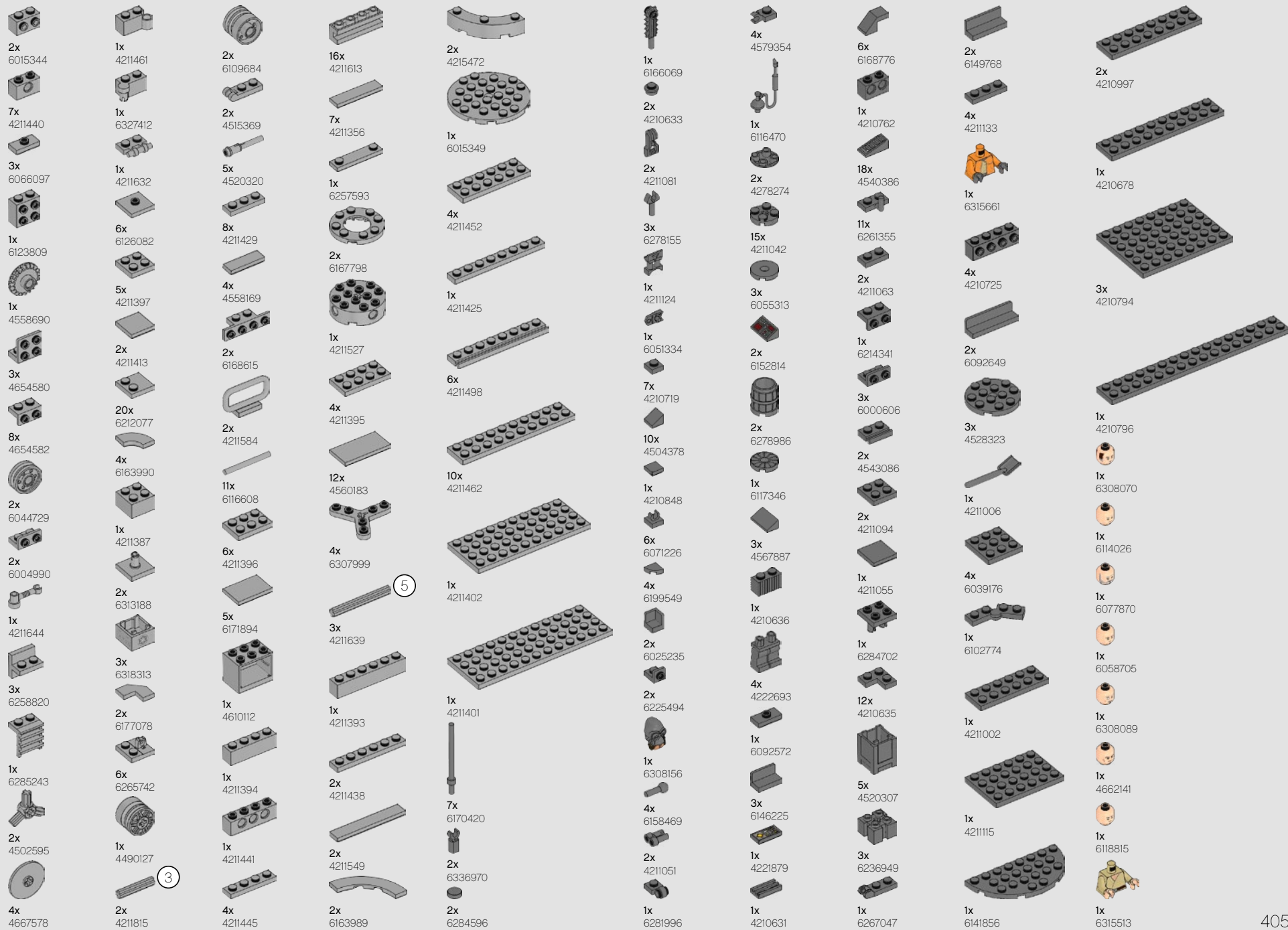



1x
6029862



1x
6278774



1x
6069913



1x
6340122

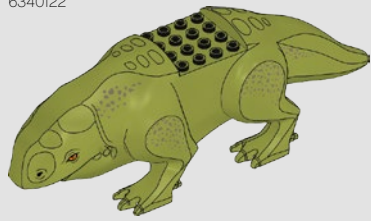

1x
6308162



1x
6299954



1x
6314440



Customer Service

Kundenservice

Service Consommateurs

Servicio Al Consumidor

LEGO.com/service or dial



00800 5346 5555 :



1-800-422-5346 :



4x
6290401



1x
6003147



1x
4529247



3x
4505990



2x
6190252



1x
6146054



1x
6283475



1x
4653753



1x
6071259



3x
6167585



1x
6078373



4x
4490599



1x
4538126



1x
6138412



1x
6138412



1x
6138412



4x
6046904



1x
6316604



1x
6308068



1x
6238674



7x
6240216



1x
6238675



2x
6251289



1x
6223655



3x
6247369



6x
6274738



1x
6240030



4x
6238856



1x
6273152



2x
6166106



9x
6163901



3x
6238673



8x
6208450



1x
6296003



2x
6170187



6x
6240214



2x
6251289



2x
6133832



1x
4535553



1x
6174246



1x
6281912



3x
4529672



1x
6063675



1x
6063666



1x
6167928



1x
6058788



1x
6213817



1x
6314069



1x
6161033



1x
6240557



1x
6240557



1x
6240557



4x
6215606



1x
6167690



1x
6248536



2x
6177146



15x
4651231



4x
6162886



2x
6021997



1x
6218360



1x
6226646



1x
6308157



4x
6102967



1x
6167599



2x
6187006



2x
6102998



2x
6102995



1x
6315809



6x
6051389



9x
6051385



1x
6290309



5x
6207840



14x
4619636



5x
6122727



1x
6275509



1x
6308158



1x
6197015



1x
6030521



1x
6236390



1x
6236390



FEEDBACK AND WIN



FEEDBACK AND WIN

Your feedback will help shape the future development of this product series.

Please visit:

FEEDBACK UND GEWINNEN

Dein Feedback trägt zur Weiterentwicklung dieser Produktreihe bei.

Geh auf:

COMMENTEZ ET GAGNEZ

Vos commentaires nous aideront à concevoir les futurs produits de cette gamme.

Rendez-vous sur :

COMENTA Y GANA

Tu opinión nos ayudará a dar forma al desarrollo de esta serie de productos en el futuro.

Visita:

反馈有奖

您的反馈将有助于我们在今后改进本系列产品。

请访问：

[LEGO.com/productfeedback](https://www.lego.com/productfeedback)

By completing, you will automatically enter a drawing to win a LEGO® set.

Terms & Conditions apply.

Durch Ausfüllen nimmst du automatisch an der Verlosung eines LEGO® Preises teil.

Es gelten die Teilnahmebedingungen.

En envoyant vos commentaires, vous serez automatiquement inscrit(e) à un tirage au sort qui vous permettra de remporter un prix LEGO®.

Offre soumise à conditions.

Al contestar, participarás automáticamente en el sorteo y podrás ganar un set LEGO®.

Sujeto a Términos y Condiciones.

完成我们的反馈调查，即可自动进入抽奖环节，赢取乐高®套装。

适用《条款和条件》。

STAR
WAR^S